

Main Catalogue

Installation Systems





Dear Partners,

Technical requirements for buildings are increasing steadily. Today, more and more installations are needed to ensure the optimum functioning of a building. The secure guidance and attachment of all types of media lines plays a particularly important role here.

With this in mind, we have expanded our range of installation and fastening elements for structural engineering. We have taken a lot of comments from practice on board and incorporated them into our systems development. Part of our special service is to offer practical solutions that will make your everyday work easier.

In our main catalogue for installation systems, we are pleased to present the SaMontec (HVAC installations), E-fix (electrical fastenings) and sanitary ware fastening ranges in a clearly laid out format. The user-orientated chapter structure puts all the different articles for one system together and simplifies the search for the elements you need.

Our complete range fulfils the highest requirements for fixing heavy loads. The fischer universal rail system FUS has been expanded and the addition of new material qualities to the stainless steel range gives you further major usage benefits.

We want to offer you the most useful products possible for your daily work. With our expanded range, we can offer you installation systems that are incredibly easy to use and extremely cost-effective. Please continue to support us with your comments so that we can continue to improve our systems and processes.

We look forward to continuing our successful cooperation.

Yours sincerely,

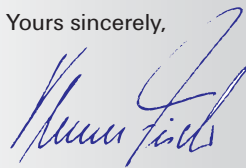

Yours, Klaus Fischer



A brand and its promise to perform

Whoever chooses fischer receives more than a range of safe products. The aim is to always develop the best solutions for our customers across the globe. Besides the innovative products, this predominantly concerns support that is focused on the customer, and services designed to improve customer benefit.

With the fischer ProcessSystem (fPS), we ensure that we are adapting and optimising our processes in line with customer requirements in a flexible manner and on a continuous basis.

Always with its finger on the pulse of the times

At fischer, innovation is more than just a sum of the patents. We are open to new things and are prepared for change – always with the aim of offering our customers the greatest possible benefits. Over the years, our own development and production sites have been developing numerous fixing solutions for the most wide-ranging applications.

Be it new production procedures or materials, such as renewable raw materials: We are carrying out the research for your safety and will continue to do so in the future. This gives us such great flexibility that we can even develop tailor-made customer solutions. This power to innovate has seen fischer become market leader in anchor technology and the fixing industry.

Safety that connects – Decisive quality

We don't make any compromises when it comes to the safety of our products. A whole host of our products are distinguished by comprehensive, up-to-date and international approvals. The fischer product range is well-positioned in all sectors of fixing technology – Steel, Nylon and Chemical fixings. In award-winning quality which continues to impress both professional clients and private customers with equal measure.





We take responsibility

Our active environment management policy means that we are helping to maintain an intact environment for our generation and for those that follow. The environment management policy at the Tumlingen site has been certified in line with DIN EN ISO 14001. We are a member of the German Sustainable Building Council (DGNB), and our products have been successively certified in line with the guidelines provided by the Institute for Construction and the Environment (IBU). With our greenline products, we have introduced the first fixing assortment in the market, based on over 50% of regrowing raw materials.



Institut Bauen und Umwelt e.V.



Our service to you

We are a reliable partner, one that will stand at your side and address your individual requirements with advice and action:

- Our products range from chemical systems to steel anchors through to plastic anchors.
- Competence and innovation through own research, development and production.
- Global presence and active sales service in over 100 countries.
- Qualified technical consulting for economical and compliant fastening solutions. Also on-site at the construction site requested.
- Training sessions, some with accreditation, at your premises or at the fischer ACADEMY.
- Design and construction software for demanding applications.

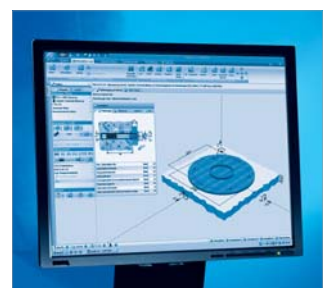
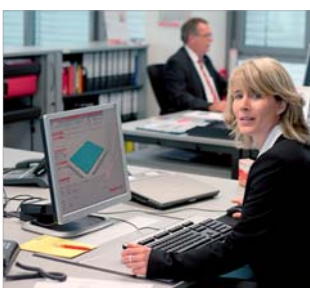

Content

Products - Detailed overview	8	1a
Basic Knowledge	23	1b
Pipe clamps	47	2
Installation system FLS	87	3
Installations system FUS	113	4
Installation grid	157	5
Fixpoint and sliding elements	167	6
Air duct and metal roof fixings	177	7
Accessories	187	8
Installation system hot-dipped galvanised	211	9
Stainless steel installation program	239	10
Air conditioner fixings	251	11
Electrical fixings	257	12
Sanitary fixings	287	13
Plugs and anchors	297	14

Pipe clamps

Type	Product Image	Qualification			Type of pipes			Example of pipes	Page
		Fire tested	VdS-approved	FM-approved	light pipes	medium heavy pipes	heavy pipes		
Hinged pipe clamp FGRS Plus					●	○	—	heating pipes, drinking water and service water pipes, medical gas supply	48
Hinged pipe clamp FGRS					●	○	—	heating pipes, drinking water and service water pipes, medical gas supply	50
Hinged pipe clamp FKS Plus for plastic pipes					●	○	—	heating pipes, drinking water and service water pipes	52
Pipe clamp FRS Plus					○	●	—	heating pipes, drinking water and service water pipes, process pipes for gases and liquids	54
Pipe clamp FRS-L Universal					●	○	—	heating pipes, drinking water and service water pipes, medical gas supply	56
Pipe clamp FRS Triple					○	●	—	gas and compressed air pipes, process pipes for gases and liquids	58
Pipe clamp FRS		✓			○	●	—	heating pipes, drinking water and service water pipes, process pipes for gases and liquids	60
Silicone pipe clamp FRSH					○	●	—	steam pipes	62
Pipe clamp FRSN Triple					○	●	—	gas and compressed air pipes, process pipes for gases and liquids	64
Pipe clamp FRSN					○	●	—	gas and compressed air pipes, process pipes for gases and liquids	66
Heavy duty pipe clamp FRSM - inch					—	●	○	heating pipes, Process pipes for gases and liquids	68
Heavy duty pipe clamp FRSM - metric					—	○	●	heating pipes, Process pipes for gases and liquids	70
Refrigeration pipe clamp FRS K					○	●	—	cooling pipes	72
Refrigeration pipe clamp KFT					—	●	○	cooling pipes	74
Sprinkler clamp FRSP				✓	○	●	○	sprinkler pipes	78
Sprinkler clamp FRSL			✓		○	●	○	sprinkler pipes	80
U-Clamp FUBD								gas and compressed air pipes, process pipes for gases and liquids	82
U-bolt ETR					○	●	○	sprinkler pipes, gas and compressed air pipes	77
Hose clamp SGS					●	○	—	rubber pipes	84

○ possible













● recommended

— not recommendable

Installation system FSL

1a

Selection guide

Type	Product Image	Qualification fire tested	Type of pipes			Example of pipes	Page
			light pipes	medium heavy pipes	heavy pipes		
Channel FLS		✓	●	○	–	heating pipes, air ventilation, drinking water and service water pipes, Medical gas supply	88
Cantilever arm ALK		✓	●	○	–	process pipes for gases and liquids, cable trays	91
Cover cap AK			●	○	–		93
Angle brace WS 31-35°			●	○	–	heating pipes, drinking water and service water pipes, cable trays	94
Sliding channel nut FSM Clix P		✓	●	○	–	heating pipes, drinking water and service water pipes, medical gas supply	98
Sliding channel nut FSM Clix M		✓	●	○	–	heating pipes, drinking water and service water pipes, medical gas supply	100
T-head bolt FHS Clix		✓	●	○	–	heating pipes, drinking water and service water pipes, medical gas supply	102
Channel washer HK 31		✓	●	○	–		110
Channel connector SV 31			●	○	–		96
Saddle flange SF Clix 31			●	○	–		104
Angle bracket MW Clix 90°			●	○	–		106
Angle bracket MW and MWU			●	○	–		108
Beam TKR 31			●	○	–		111

○ possible ● recommended – not recommendable

Installation system FUS









Type	Product Image	Qualification fire tested	Type of pipes			Example of pipes	Page
			light pipes	medium heavy pipes	heavy pipes		
Channel FUS		✓	○	●	○	heating pipes, drinking water and service water pipes, gas and compressed air pipes	114
Channel connector FUF OC und PFUF OC			○	●	○	heating pipes, drinking water and service water pipes, gas and compressed air pipes	119
Cantilever arm FCA		✓	—	●	○	process pipes for gases and liquids, cable trays	120
Large cantilever arm FCAM			—	●	●	heating pipes, Cooling pipes, process pipes for gases and liquids	124
Cover cap FEC			—	—	—		125
Push-through connector PFCN 41			○	●	○		126
Connector FCN Clix P and FCN Clix M		✓	○	●	○	heating pipes, drinking water and service water pipes, medical gas supply	138
Channel nut FCN Clix M		✓	○	●	○	heating pipes, drinking water and service water pipes, medical gas supply	138
T-head bolt FHS Clix S			○	●	○	heating pipes, drinking water and service water pipes, medical gas supply	140
Channel nut FCN			○	●	○	ventilation pipes, gas and compressed air pipes	142
Channel washer HK 41		✓	○	●	○		143
Saddle flange PSF			○	●	○	heating pipes, drinking water and service water pipes, gas and compressed air pipes	128
Universal bracket PUWS			○	●	○	heating pipes, drinking water and service water pipes, gas and compressed air pipes	129
Angle bracket PWK			○	●	○	heating pipes, drinking water and service water pipes, gas and compressed air pipes	130
Variable bracket PVB			○	●	○		131
Bracing elements PSAE			○	●	○		132
Bracket PFFF			○	●	○	heating pipes, drinking water and service water pipes, gas and compressed air pipes	134
Bracket PFAF			○	●	○	heating pipes, drinking water and service water pipes, gas and compressed air pipes	135
Bracket PFUF			○	●	○	heating pipes, drinking water and service water pipes, gas and compressed air pipes	136
Bracket PFUF D			○	●	○		137

○ possible ● recommended — not recommendable

Installation system FUS

1a

Selection guide

Type	Product Image	Qualification fire tested	Type of pipes			Example of pipes	Page
			leichte Leitung	medium heavy pipes	heavy pipes		
Saddle flange SF		✓	—	●	○		144
Universal bracket UWS		✓	—	●	○		145
Angle bracket WK			○	●	○		146
Angle bracket FAF			○	●	○		135
Bracket FZF			—	●	○		154
Bracket FFF			○	●	○		152
Threaded rod bracket FSB 45°			○	●	○		150
Universal mounting UHRS			—	●	○		148
Beam clamp TKR			○	●	○		151

○ possible





● recommended

— not recommendable

1a

Installation Grid

Selection guide

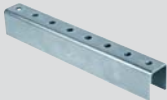
Type	Product Image	Type of pipes			Example of pipes	Page
		light pipes	medium heavy pipes	heavy pipes		
Channel FUS		○	●	○	heating pipes, drinking water and service water pipes, gas and compressed air pipes	161
Cross connector FVS		—	●	○	ventilation ducts and ventilation pipes, drinking water and service water pipes, gas and compressed air pipes, process pipes for gases and liquids, cable trays	160
Channel nut FCN Clix P		○	●	○	heating pipes, drinking water and service water pipes, gas and compressed air pipes	165
Universal mounting UHRS		—	●	○		165
T-head bolt FHS Clix S		○	●	—	heating pipes, drinking water and service water pipes, medical gas supply	164
Hexagonal connector VM		●	●	●		163
Turnbuckle SPS, Bolt left-hand/right-hand BLR		—	●	○	Installation grid	163
Channel connector FUF OC		—	●	○		161
Beam clamp TKR		●	●	—	ventilation ducts and ventilation pipes, sprinkler pipes, water and waste water treatment	163

○ possible







● recommended

— not recommendable







Fixpoint and Sliding Elements

1a

Selection guide

Type	Product Image	Qualification			Type of pipes			Example of pipes	Page
		fire tested			light pipes	medium heavy pipes	heavy pipes		
Sound insulated fix point FSFP					○	●	○	heating pipes, drinking water and service water pipes plumbing, cooling pipes	168
Fixpoint clamp FFPS and -saddle FFPK					○	●	●	heating pipes, drinking water and service water pipes plumbing, cooling pipes	169
Sliding element GL					○	●	○	heating pipes, drinking water and service water pipes plumbing, cooling pipes	170
Sliding saddle SBS		✓			○	●	●	heating pipes, drinking water and service water pipes plumbing, cooling pipes	171
Sliding element FSC1					●	○	—	heating pipes, drinking water and service water pipes plumbing, cooling pipes	172
Sliding hanger SB		✓			●	○	—	heating pipes, drinking water and service water pipes plumbing, cooling pipes	173
Pendulum hanger PDH / PDH K		✓			○	●	○	heating pipes, drinking water and service water pipes plumbing, cooling pipes	174

Air duct and Metal roof fixings

Type	Product Image	Qualification			Type of pipes			Example of pipes	Page
		fire tested	VdS-approved	FM-approved	light pipes	medium heavy pipes	heavy pipes		
Ventilation duct clamp LGS					●	○	—	ventilation pipes	178
Duct hanger L- and Z-type					●	○	—	ventilation pipes	180
Spiral duct hanger LRBN / LRB					●	○	—	ventilation ducts	181
Rubber inlay EMS					●	○	—	ventilation ducts and ventilation pipes	184
Profile hanger TZ / TZH			✓	✓	○	●	—	ventilation ducts and ventilation pipes, sprinkler pipes, water and waste water treatment	182
Hole punch LZ, hole stamp LST									183

○ possible

● recommended

— not recommendable

Accessories

















Type	Product Image	Qualification				Type of pipes			Example of pipes	Page
		fire tested	VdS-approved	FM-approved	UL-approved	light pipes	medium heavy pipes	heavy pipes		
Clamp hanger TKL			✓	✓	✓	●	●	—	ventilation ducts and ventilation pipes, sprinkler pipes, water and waste water treatment	188
Beam Clamp Steel TKLS Steel Bite			✓	✓		●	●	—		190
Threaded rod G / Threaded stud GS						●	●	●		192
Base plate GPL						○	●	—	ventilation ducts and ventilation pipes, sprinkler pipes, water and waste water treatment	194
Base plate GPR										194
Stud screw STST with bit head and Hex shank						●	●	—	heating pipes, water and waste water treatment	195
Support hanger AHB						●	●	●		196
Multi connector MW						●	—	—		197
Parallel connector PV						●	○	—		198
Double connector plate DPP, DPF						●	○	—	heating pipes, water treatment	199
Installation tool for stud screw HED										200
Turnbuckle SPS, Bolt left-hand/right-hand BLR						—	●	○	Installation grid	200
Bolt connector SBB						●	○	—		200
Hexagonal nut SKS						●	●	○		201
Washer U						●	●	●		201
Hexagonal nut MU						●	●	●		202
Hexagon connector VM						●	●	●		202
Eyebolt AG						●	●	—		202
Thread hanger RAH						●	●	—		203
Reduction pieces						●	●	—		203
Reduction socket RDM und GRD						●	○	—		204
Flat eye screw LLS						●	●	—		204
Textile web strapping GWB						●	○	—	heating pipes, water and waste water treatment, temporary pipes	205
Perforated steel banding LBV / LBK						●	○	—	heating pipes, water and waste water treatment, temporary pipes	206
Impact nail ED						●	—	—		207
Impact nail setting tool SZE										208

○ possible ● recommended — not recommendable

Installation system FUS hot-dip galvanised

1a

Selection guide

Type	Product Image	Qualification fire tested	Type of pipes			Example of pipes	Page
			leichte Leitung	medium heavy pipes	heavy pipes		
Channel FUS hdg.		✓	—	●	○	heating pipes, drinking water and service water pipes, gas and compressed air pipes	212
Cantilever arm FCA hdg.		✓	—	●	○	process pipes for gases and liquids, cable trays	217
Large cantilever arm FCAM hdg.							220
Cover cap FEC							221
Connector FCN Clix P hdg. / FCN Clix M hdg.		✓	—	●	○		222
Channel washer HK 41 hdg.		✓	○	●	○		224
Saddle flange SF hdg.		✓	—	●	○		225
Mounting bracket UWS hdg.		✓					226
Angle bracket WK hdg.							227
Bracket FAF hdg.							235
Flanges FUF hdg.							236
Bracket FFF hdg.			○	●	○		233
Variable bracket VB hdg.			—	●	○		229
Threaded rod bracket FSB 45° hdg.							230
Beam clamp TKR hdg.							231
Channel connector FUF OC hdg.							216

○ possible

● recommended

— not recommendable

1a

Stainless steel installation program

Selection guide

Type	Product Image	Qualification fire tested	Type of pipes			Example of pipes	Page
			light pipes	medium heavy pipes	heavy pipes		
Pipe clamp FRS			○	●	—	heating pipes, drinking water and service water pipes, medical gas supply	240
Channel MS			●	○	—	heating pipes, drinking water and service water pipes, medical gas supply	241
Cantilever arm ALK A2			●	○	—	process pipes for gases and liquids, cable trays	241
T-head bolt FHS Clix A2			●	○	—	heating pipes, drinking water and service water pipes, medical gas supply	241
Installation angle bracket MW A2			●	○	—	gas and compressed air pipes, process pipes for gases and liquids	242
Saddle flange SF A2			●	○	—		242
Channel nut HG A2			●	○	—	gas and compressed air pipes, process pipes for gases and liquids	242
FUS Channel A2/A4		✓	○	●	○	heating pipes, drinking water and service water pipes, gas and compressed air pipes	243
Cantilever arm FCA A4		✓	—	●	○	process pipes for gases and liquids, cable trays	244
Saddle flange SF L A4		✓	—	●	○		244
Mounting bracket FAF A4			—	●	○		244
Beam clamp TKR			—	●	○		245
Channel washer HK 41		✓	○	●	○		245
Clix channel nut FCN Clix A4		✓	—	●	○	heating pipes, drinking water and service water pipes, gas and compressed air pipes	246
Stud screw STS A2/A4			●	●	—	heating pipes, water and waste water treatment	246
Threaded rod G A2/A4		✓	●	●	○	ventilation ducts and ventilation pipets	247
Threaded stud GS A4		✓	●	●	○	ventilation ducts and ventilation pipets	247
Hexagonal connector VM A4			●	●	○		247
Washer U A4			●	●	○		248
Hexagonal nut MU A4			●	●	○		248
Hexagonal screw SKS A4			●	●	○		248



○ possible

● recommended

— not recommendable















Air conditioner fixings

1a

Product		Applications	Page
Type	Image		
Air conditioner fixing MCE		air conditioner on wall	252
Air conditioner fixing KSU		air conditioner on wall	254
Sound absorption element PA		air conditioner wall fixed, fans and pumps	255

Selection guide

Electrical fixings





Product		zinc plated	hdy	A4	C (1.4529)	Principles of function	Type of installation	Anchoring base		Approval		Application recommendation	Page
Type	Image							Concrete	Masonry	ETA	ICC		
ClipFix plus LS/ES/ZS						c)		✓				conduits, flexible pipes	258
ClipFix plus SD						c) 2)		✓				trunking, strips, profiles	260
Cable clasp KB						c) 2)		✓				conduits	262
Cable harness SHA												conduits, flexible and rigid plastic pipes	264
Pipe clip RC												rigid plastic pipes	266
Pipe clip FC												conduits, flexible and rigid plastic pipes	268
Saddle clip SCH												conduits, flexible and rigid plastic pipes	270
Nail clip NS / MNS						c)			✓			conduits	272
Nail disc NSB						c)				✓		cables in wall slots	274
Spacer pipe clamp AM		✓										metal conduits according to DIN 49020	276
Conduit clip BSM		✓										conduits, flexible and rigid plastic pipes, metal conduits	278
Impact nail ED		✓				c)						conduit clips	280
Cable tie BN / UBN												conduits, flexible and rigid plastic pipes	282
Wireclip WIC												for suspension of lighting, trunking, busbar	284

1) Pre-positioned installation 2) Push-through installation 3) Stand-off installation
a) Adhesive locking b) Interlocking c) Friction locking

Sanitary fixings

1a

Selection guide

Type	Product Image	zinc plated	hdy	A4	C (1.4529)	Principles of function	Type of installation	Anchoring base		Approval		Application recommendation	Page
								Concrete 	Masonry 	ETA	ICC		
Sanitary fixings for board materials		✓				b) c)	2)	✓	✓			wash basins and urinals	288
Ceramic fixings		✓				c)	1) 2)	✓	✓			free-standing toilets	290
Thermal insulation blocks		✓				c)	1) 2)	✓	✓			wash basins and urinals	292

- 1) Pre-positioned installation 2) Push-through installation 3) Stand-off installation
a) Adhesive locking b) Interlocking c) Friction locking

3D CAD Database



Your advantages

- 2D and 3D export possible
- Various drawing formats selectable
- low and high level of details
- 3D preview with spatial rotation
- direct export from database into CAD system

www.fischer.de/cad

Product Online Catalogue

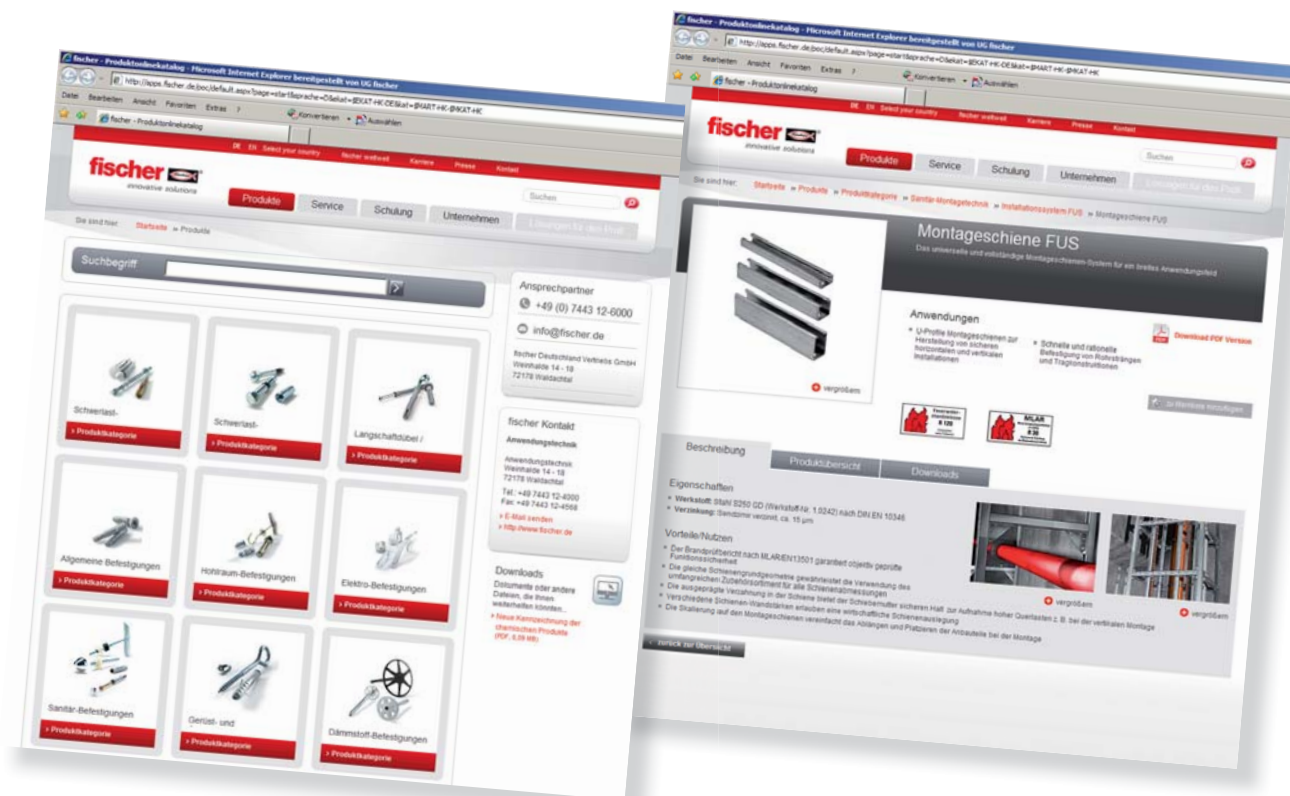

Your advantages

- Latest product information with continuous updating and/or expansion.
- Clear organization based on the printed catalogue.
- Simple navigation within the catalogue.
- Access to all important technical data, load tables and approvals and also CAD details in 2D and 3D.
- Technical tables separated according to materials with reference to current approvals.
- Compare the products in clear tables.
- Put your own catalogue together using the PDF export function – a PDF file will be generated from the current database.
- Product search allows you fast, direct access to product information.
- Looking for approvals? Under “Technical Documents” you will find the current document you are looking for with data on the approval number, validity and language version.

www.fischer.de
Fixing Systems – Products heading

fischer hammer drill bits

Unstoppable.



The fischer bit product range

Perfect shape. Optimum drive.



Content Basic knowledge

1b

Basic knowledge

	page
Maintenance groups and applications for mounting pipe installations	23
Product solutions with examples	24
Elongation	26
Soundproofing	27
Corrosion protection	28
Fire protection	29
Mounting sprinkler systems	33
Mounting gas pipe	34
Seismic and dynamic	35
Dimension and weights of pipes, ventilation ducts and ventilation pipes	36
Important dimensions, variables and units	40
Approvals, markings and their importance	42

Maintenance groups and applications for mounting pipe installations

The mounting of pipe installations, distribution systems and devices in various types of buildings, as well as industrial plants and processes are combined under the umbrella term, installation systems. fischer SaMontec is a complete range including the most important supplementary products, in particular plugs and anchors.

The following belong to the maintenance groups which install pipes

- Heating, ventilation and cooling systems
- Plumbing
- Sprinklers - extinguishing systems
- Electrical installations (medium and low voltage)
- Water and waste water treatment
- Energy and water supply

Through these maintenance groups, different pipe installations, which are offered by the SaMontec product range, are created:

- Heating and cooling pipes
- Steam pipes
- Ventilation ducts and ventilation pipes
- Drinking water and service water pipes
- Waste water and drainage water pipes
- Sprinkler pipes
- Gas and compressed air pipes
- Medical gas supply
- Process pipes for gases and liquids
- Water and waste water treatment
- Energy and water supply

Product solutions with examples

Installation shaft with FUS channel system

Through the distinctive interlocking of the channels for the channel nuts FCN Clix P or PFCN, the FUS channel system provides a secure grip for handling high shear loads.

Also the first choice for pipe line routes due to the greater stability.



Cantilevers for different load ranges

With centred load (load case 1), the load range of the brackets is between 0.33 kN (33 kg) and 7.5 kN (750 kg).

Lightweight cantilevers in the FLS system: ALK

Medium cantilevers in the FUS system: FCA

Massive cantilevers in the FUS system: FCAM



Pre-assembled construction element

The pre-assembled construction elements MW Clix 90° und SF Clix 31 guarantee for a time saving installation.

The time saving in comparison to usual U-profile file system is around 70%.



Fix points and sliding components

Sound insulation requirements for fix points: FSFP anchor point

For all standard cases: FFPS fix point with FFPK

Fixing ensures controlled movement in one direction: Sliding elements (see instructions on this under Elongation)

See chapter on anchors and sliding elements.



Product solutions with examples



Refrigerant pipe clamp with integrated steel bracket

Different requirements for insulating layer thicknesses and the prevention of condensation are the basic requirements for a refrigerant pipe clamp.

The KFT refrigerant pipe clamp allows neat bonding for insulating layer thicknesses of up to 30 mm, 40 mm or 60 mm.



Sprinkler loop with VdS and FM approval

Sprinkler systems are created according to the requirements of property insurers. The association of property insurers, VdS and FM global, testing products and give approvals for installation in water extinguishing systems. The FRSL and FRSP sprinkler clamp are approved sprinkler loops.

See also Mounting sprinkler installations.



Channel connection - which loads are relevant?

In the design of supports or similar components for mounting pipe installations, the load of the connecting element, such as a hammer-head screw (e.g. FHS Clix S) or channel nut (e.g. FCN Clix P) is decisive for the connection with a angle bracket, for example. The load information is shown for one element, but can be doubled when using two elements. (see example left side).

Elongation



Materials expand with heat. For long components, the change in length is mainly considered. So it is not always a matter of expansion. Shrinkage upon cooling is to also be included in the calculation. This is important when installing pipes. Within piping, the change in length is to be specifically steered. Not doing this during installation results not only in pipe defects, but also in serious damage to components. It is therefore essential to determine how great the change in the length of a pipe can be. For this purpose, the pipe length and the expansion coefficient of the pipe material, as well as the expected temperature difference, must be known. This is to be determined such that not only the normal operating temperatures, but also the maximum temperatures that can arise in a case of malfunction, are taken into account. The range is therefore from around 10 °C assembly temperature up to 95°C service temperature for water filled systems.

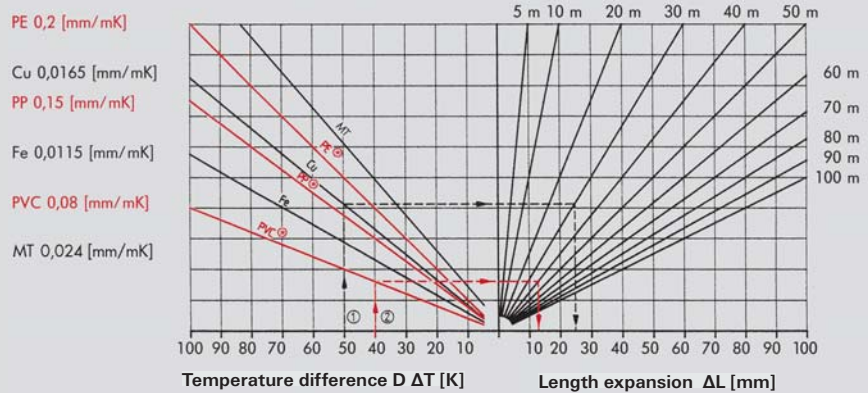

Note:
For plastic pipes (PE, PP, PVC), the length expansion read from the diagram is to be multiplied by a factor of 10.

Example:

- ① Copper pipe, Cu – Length of pipe span 30 m
Temperature difference $\Delta T = 50$ K
Length expansion $\Delta L = 24,75$ mm
- ② PVC pipe – Length of pipe span $L = 40$ m
Temperature difference $\Delta T = 40$ K
Length expansion $\Delta L = 128$ mm (table value x10)

Length expansion calculation formula

$$\Delta L = L \cdot \Delta T \cdot \alpha$$

[mm] [m] [K] [mm/m K]

- ΔL = Change in length
- L = Length of the pipe span/section
- ΔT = Temperature difference
- α = Length expansion coefficient

Soundproofing



As defined in the appropriate standards, the goal of soundproofing is to reduce the transmission to other apartments or usage areas to a given noise range. The upper limits for permissible residual noise levels are defined in the standards.

Soundproofing - VDI 4100

In principle, the VDI 4100 values are, among other things, protection against noise from building systems that are mounted in the neighbouring area. According to VDI 4100, living areas are rooms that are in need of protection; in apartments, these are all rooms with a floor space of $> 8\text{m}^2$. This includes kitchens, bathrooms, toilets, hallways and ancillary rooms. VDI 4100 further recommends agreeing with the contracted companies the sound insulation values $\text{SSt EB I} = 35\text{ dB}$ or $\text{SSt EB II} = 30\text{ dB}$ for noise emerging from one's own area. Exceptions to this are all sounds that are influenced by the residents, i.e. self-installed air conditioners in the apartment or noises from flushing toilets, etc.

Soundproofing - DIN 4109

The DIN 4109 from 2016-07 still supplemented by A1 (2001-01), in which the permissible sound pressure level in living and sleeping areas for noise from building installations was reduced from 35 to 30 dB(A). The standard is not applicable to the protection against noise from building installations in one's own living area, but only to sounds coming from "external" areas as defined in VDI 4100. For increased sound insulation, DIN 4109 Addendum 2 (from 1989) specifies a reduction in the permissible values by 5 dB(A) (to 25 dB(A)) as effective for noises from building installations.

Soundproofing - important influential factors for pipe mounting

Sound propagates in vibrations. These sound waves can propagate in solid, liquid and gaseous media, where the speed of this sound propagation differs greatly in the various media. So the sound in pipe installations is primarily forwarded through the pipeline itself and not through the carried medium. Transmission over the metal pipe is faster than in water, for example. In welded heating systems, for example, the individual sounds of striking a pipe can propagate throughout the entire building. The sound waves are transmitted in a medium in that the molecules constantly jolt one another, thereby transmitting the wave. Steel pipes or metallic mounting elements have an ordered metallic lattice, wherein forwarding is faster and with less loss than in amorphous materials, such as rubber (general elastomers). It can thus be determined that an inversely proportional relationship exists between the speed of sound [symbol; c] and the insulating behaviour of materials. That is, materials with a low sound speed always have better insulating properties than materials with a high sound speed (steel $c = 5100\text{ m/s}$). Rubber ($c \sim 40\text{ m/s}$) is therefore eminently suitable for sound insulation. In rubber, the sound waves stop dead, so to speak, wherein the energy is converted into heat.

Therefore, the sound isolation must in principle occur between the pipes and the structure. Here, we recommend the installation of a sound insulating element as close to the sound source as possible; in the simplest case, with an insulating insert in the pipe clamp itself. Sound tested pipe clamps by fischer FRS Plus pipe clamp, FRS pipe clamp and FRS-L Universal pipe clamp.

Corrosion protection



In most cases, pipes and supply lines are installed in dry rooms. Therefore, in addition to corrosion resistant materials, such as plastics or stainless steel and copper, the steel products used for installation systems are galvanised. A zinc coating thickness of 5-8 µm by means of electrolytic process (galvanising) is standard.

For mounting rails, Sendzimir galvanised material is mainly used. Sendzimir galvanising is a method in which the material is drawn through a molten zinc bath, thereby achieving a zinc layer thickness of 12-20 µm. This method is used when there is no more welding for the subsequent processing. This is the case for mounting rails because they are cold-formed after galvanising. By cutting and stamping the holes, the surface in this area is not completely covered by a protective layer. Punched mounting rails are therefore only recommended for the dry interior rooms.

For cantilever brackets, non-galvanised channel pieces are used which are welded to the base plate. Following completion, the entire component is galvanised, creating a zinc coating thickness of 5-8 µm.

Threaded parts are either galvanised or made of stainless steel. Hot dip galvanising is less suitable for this because the large zinc layer thickness of 40-150 µm severely impairs the thread engagement.

If installation systems are installed outdoors or in wet interior rooms, they must be made of either hot dip galvanised steel or stainless steel.

Hot dip galvanising is very well suited to the protection of steel. The corrosion process is thus 10 times slower than with galvanising. The zinc loss depends on the surrounding atmosphere and humidity. An annual zinc reduction of 1 - 10 µm can, however, be assumed. The layer thickness is therefore crucial to the durability of the material.

Crucial here are the environmental influences under which the systems are installed. An overview of the expected impact on the protective action can be seen in the following diagram and tables.

hot-dip galvanized steel:

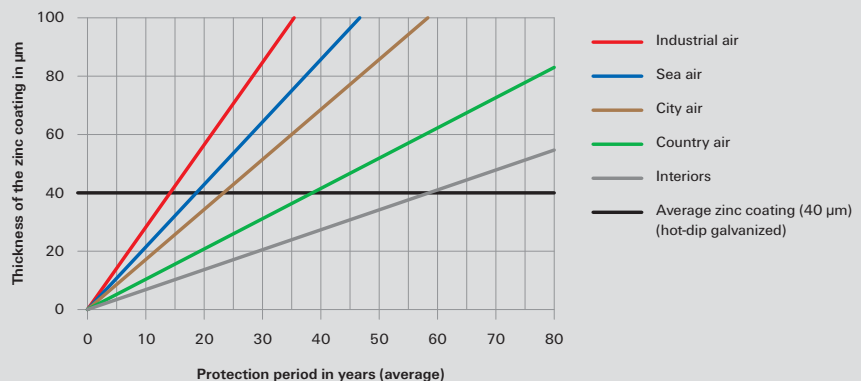

Stainless steel

Steel Grade				Designation of the Steel Group with	Corrosion	
Material No.	Short Name	AISI	UNS		Resistance Class	Exposure and Typical Applications
1.4305	X8CrNiS18-9	303	S 30300	A1	I / light	Indoor climate except damp location.
1.4301	X5CrNi18-10	304	S 30400	A2	II / moderate	Accessible constructions without nameable content of chlorides or sulfur dioxide, except industrial atmosphere.
1.4307	X2CrNi 18-9	304L	S 30403	A2L		
1.4362	X2CrNiN23-4	324	S32304	A4	III / medium	Constructions with moderate chloride and sulfur dioxide exposure and inaccessible constructions.
1.4401	X5Cr-NiMo17-12-2	316	S 31600			
1.4404	X2Cr-NiMo17-12-2	316 L	S 31603	A4L		
1.4571	X6CrNi-MoTi17-12-2	316 Ti	S 31635	A5	IV / strong	High corrosion exposure due to chlorine, chloride and/or sulfur dioxide, high humidity as well as accumulation of hazardous substances.
1.4529	X1NiCrMo-CuN25-20-7	-	N 08926	1.4529		

Fire protection

Fire protection in pipe installations according to the latest standards.

- Fire-proof installations for individual pipes and pipe routes from R30 - R120 or F30 to F120.
- Proof of compliance with the criteria of MLAR (German standard pipe system directive) for installation in escape and rescue routes

Fire protection - protection goals

Firstly, fire protection serves to protect people, and is regulated by the building laws in the respective countries (or regional states). Secondly, fire protection serves to protect property and this is regulated by the insurance associations, such as VdS and FM. These requirements partially go beyond the building legislation. This is particularly evident in the installation of fire protection systems, such as sprinklers, etc., as approved or recognised components must be used here. (See the following section for further details on this)

Fire inspection reports for the mounting of pipe clamps and mounting rails

Fire safety inspection reports meet the requirements for fire protection according to the building regulations of the countries and, especially for Germany, according to the nationwide homonymic German pipe systems directive (LAR), based on the standard pipe systems directive of 2005 (MLAR 2005).

Personal protection is defined in the MLAR Directive through clear rules for escape routes, such as corridors, stairwells and hallways between stairwells and the exit.

The key message is to ensure the safety of the escape route by ensuring the functioning of the fire-proof sub-ceiling. To this end, compliance with the minimum distance of $\min a \leq 50$ mm according to MLAR is required between installations and underlying suspended fire-proof F30 sub-ceilings (fire resistance of 30 minutes). Based on the fire inspections, load information for a fire resistance of 30 minutes in relation to the maximum

Permissible deformation of mounting rails or pipe clamps, for example, was determined. The necessity for these considerations arises from the properties of the steel, which at 30 minutes is subjected to a temperature of >800 °C according to the standard temperature curve (ISO curve).

Reduction factors k_{θ}

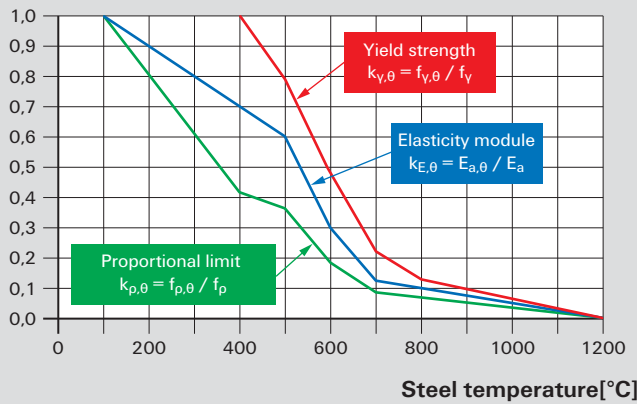

Dependency of the yield strength, proportional limit and elasticity module on the temperature (basis: EN1993-1-2:2012-12 Eurocode 3).

Additionally, the same information is documented in the inspection reports for a fire resistance rating of R30, R60, R90 and R120 according to EN1363-1 and DIN4102-2. (see following load tables)

Product overview with proof in inspection reports and supplementary sheets.

Product	Document no.	MLAR	R30 - R120	F30 - F120
FRS	MFPA Leipzig - GS 3.2/14-175-2	•	•	
FUS / FCA	MFPA Leipzig - GS 3.2/14-175-4	•	•	
FRS-L Universal	MFPA Leipzig - GS 3.2/15-141-3	•	•	
FLS / ALK	MFPA Leipzig - GS 3.2/15-141-4	•	•	
SB	MPA-NRW - 210005109-7			•
SBS	MPA-NRW - 210005109-4	•		•
PDH-K	MPA-NRW - 210005109-6	•		•

Load tables based on fire protection inspection reports.

Pipe clamp FRS - Load table based on the Advisory Opinion No. GS 3.2/14-175-2

The following figures are valid for all FRS-L Universal pipe clamps, galvanized, hdg and stainless steel.

FRS M8/M10		MLAR-loads		Max. Loads				
Threaded rods ≥ 4.8		strain	F-resistance	Max. strain	Fire resistance time [minute]			
Clamping range	h_a	min a	30	min a	30	60	90	120
[mm]	[mm]	[mm]	[kN]	[mm]	[kN]	[kN]	[kN]	[kN]
12 - 67	≤ 250	≤ 50	0,56	51	0,56	0,29	0,20	0,15
	≤ 500	≤ 50	0,56	54				
	≤ 750	≤ 50	0,56	57				
	≤ 1000	≤ 50	5,51	60				
72 - 92	≤ 250	≤ 50	0,65	50	0,79	0,49	0,36	0,29
	≤ 500	≤ 50	0,62	53				
	≤ 750	≤ 50	0,59	56				
	≤ 1000	≤ 50	0,57	59				
108 - 116	≤ 250	≤ 50	0,48	61	0,63	0,39	0,29	0,23
	≤ 500	≤ 50	0,43	64				
	≤ 750	≤ 50	0,39	66				
	≤ 1000	≤ 50	0,35	69				
121 - 168	≤ 250	≤ 50	0,96	61	1,00	0,51	0,34	0,25
	≤ 500	≤ 50	0,89	63				
	≤ 750	≤ 50	0,82	66				
	≤ 1000	≤ 50	0,85	69				

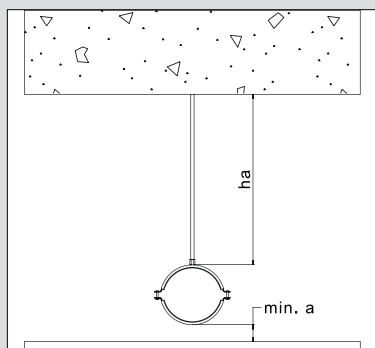

Pipe clamp FRS-L Universal - Load table based on the Advisory Opinion No. GS 3.2/15-141-3

The following figures are valid for all FRS-L Universal pipe clamps, galvanized, hdg and stainless steel.

FRS-L Universal M8/M10		MLAR-loads		Max. Loads				
Threaded rods ≥ 4.8		strain	F-resistance	Max. strain	Fire resistance time [minute]			
Clamping range	h_a	min a	30	min a	30	60	90	120
[mm]	[mm]	[mm]	[kN]	[mm]	[kN]	[kN]	[kN]	[kN]
8 - 37	≤ 250	≤ 50	0,27	54	0,27	0,14	0,09	0,07
	≤ 500	≤ 50	0,26	57				
	≤ 750	≤ 50	0,24	60				
	≤ 1000	≤ 50	0,22	62				
38 - 66	≤ 250	≤ 50	0,17	72	0,29	0,14	0,09	0,06
	≤ 500	≤ 50	0,16	75				
	≤ 750	≤ 50	0,15	78				
	≤ 1000	≤ 50	0,13	80				
67 - 119	≤ 250	≤ 50	0,53	75	0,53	0,35	0,27	0,22
	≤ 500	≤ 50	0,53	78				
	≤ 750	≤ 50	0,53	81				
	≤ 1000	≤ 50	0,53	83				

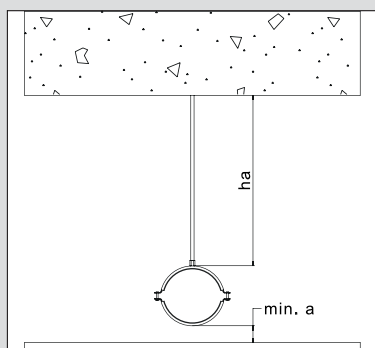

FUS-Channel/FCA-Cantilever arm - Load table based on the Advisory Opinion No. GS 3.2/14-175-4

The following figures are valid for FUS channels and FCA cantilever arms, galvanized, hdg and stainless steel

FUS / FCA 41/2,5 (picture 1-3)		MLAR -loads		Max. Loads				
Threaded rods ≥ 4.8		strain	F-resistance	Max. strain	Fire resistance time [minute]			
Load case	l_s	min a ¹⁾	30	min a ²⁾	30	60	90	120
	[mm]	[mm]	[kN]	[mm]	[kN]	[kN]	[kN]	[kN]
Point load	≤ 400	≤ 50	0,90	278	2,40	1,33	0,92	0,72
	≤ 700	≤ 50	-	320	1,61	1,04	0,80	0,67
Multiple load ³⁾	≤ 400	≤ 50	0,90	278	2,40	1,33	0,92	0,72
	≤ 700	≤ 50	-	320	1,61	1,04	0,80	0,67
Uniformly distributed load	≤ 400	≤ 50	1,50	258	3,00	2,10	1,41	1,06
	≤ 700	≤ 50	0,60	299	2,44	1,57	1,21	1,00
	≤ 1250	≤ 50	-	468	3,29	1,81	1,27	0,98

FUS / FCA 62/2,5 (picture 1-3)		MLAR -loads		Max. Loads				
Threaded rods ≥ 4.8		strain	F-resistance	Max. strain	Fire resistance time [minute]			
Load Case	l_s	min a ¹⁾	30	min a ²⁾	30	60	90	120
	[mm]	[mm]	[kN]	[mm]	[kN]	[kN]	[kN]	[kN]
Point load	≤ 400	≤ 50	1,76	25	1,76	1,06	0,78	0,62
	≤ 700	≤ 50	-	460	2,27	1,31	0,93	0,72
Multiple load ³⁾	≤ 400	≤ 50	1,76	25	1,76	1,06	0,78	0,62
	≤ 960 ⁴⁾	≤ 50	4,30	550	4,30	2,14	1,39	1,01
Uniformly distributed load	≤ 400	≤ 50	0,55	661	2,52	1,60	1,21	0,99
	≤ 960 ⁴⁾	≤ 50	1,76	25	1,76	1,06	0,78	0,62
	≤ 1000	≤ 50	0,55	661	2,52	1,60	1,21	0,99
≤ 1250	≤ 50	0,50	592	2,41	1,65	1,31	1,11	

FUS 62/2,5 (picture 4)		MLAR -loads		Max. Loads				
Vertical FUS 41/2,5		strain	F-resistance	Max. strain	Fire resistance time [minute]			
Load case	l_s	min a ¹⁾	30	min a ²⁾	30	60	90	120
	[mm]	[mm]	[kN]	[mm]	[kN]	[kN]	[kN]	[kN]
Point load	≤ 1000	≤ 50	0,57	369	1,33	0,87	0,68	0,57
Multiple load ³⁾	≤ 1000	≤ 50	0,62	649	1,92	1,34	1,08	0,92
Uniformly distributed load	≤ 1000	≤ 50	0,62	649	1,92	1,34	1,08	0,92

¹⁾ Valid for a suspension height $h_a \leq 500$ mm
²⁾ Based on suspension height $h_a = 250$ mm, Expansion length of threaded rods in case of fire ~ 10 mm/m
³⁾ Given load values apply for multiple loads as summated point loads symmetrical allocated
⁴⁾ This values are valid for FCA 62/2,5 with additional support by threaded rod

Picture 1 - 3 are valid for FUS/FCA and FLS/ALK load tables

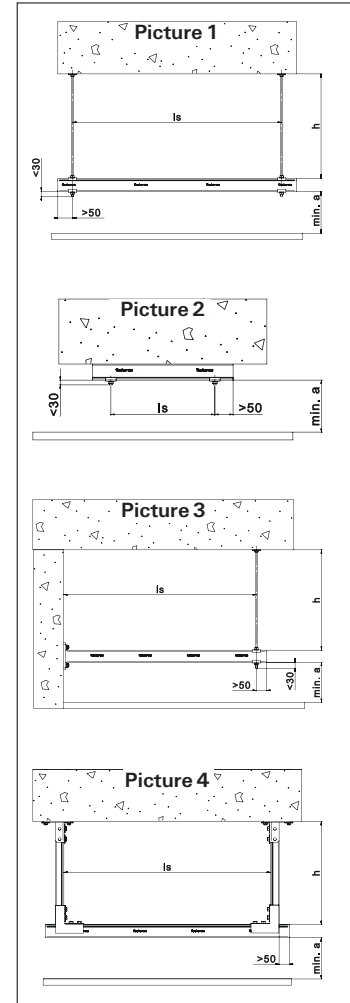

FLS-Channel/ALK-Cantilever arm - Load table based on the Advisory Opinion No. GS 3.2/14-175-7

The following figures are valid for FLS channels and ALK cantilever arms, galvanized, hdg and stainless steel

FUS / FCA 41/2,5 (picture 1-3)		MLAR -loads		Max. Loads				
Threaded rods ≥ 4.8		strain	F-resistance	Max. strain	Fire resistance time [minute]			
Load case	l_s	min a	30	min a	30	60	90	120
	[mm]	[mm]	[kN]	[mm]	[kN]	[kN]	[kN]	[kN]
Point load	≤ 400 ¹⁾	≤ 50	0,24	93	0,24	0,13	0,10	0,09
	≤ 400 ²⁾	≤ 50	0,09	289	0,47	0,38	0,33	0,30
	≤ 400 ⁴⁾	≤ 50	0,32	226	1,33	0,78	0,53	0,40
Multiple load ³⁾	≤ 400 ¹⁾	≤ 50	0,72	93	0,72	0,38	0,30	0,27
	≤ 400 ²⁾	≤ 50	0,26	289	1,42	1,13	0,99	0,90
	≤ 400 ⁴⁾	≤ 50	0,81	226	1,33	0,78	0,53	0,40
Uniformly distributed load	≤ 400 ¹⁾	≤ 50	0,72	93	0,72	0,38	0,30	0,27
	≤ 400 ²⁾	≤ 50	0,35	308	1,37	1,19	1,06	0,95
	≤ 400 ⁴⁾	≤ 50	0,81	226	1,33	0,78	0,53	0,40

¹⁾ Valid for a suspension height $h_a = 0$ mm, s. picture 2
²⁾ Valid for a suspension height $h_a = 500$ mm, s. picture 1 (Expansion length of threaded rods in case of fire ~ 10 mm/m)
³⁾ Given load values apply for multiple loads as summated point loads symmetrical allocated
⁴⁾ This values are valid for ALK 37-450 with additional support by threaded rod, s picture 3 ($h_a = 500$ mm)

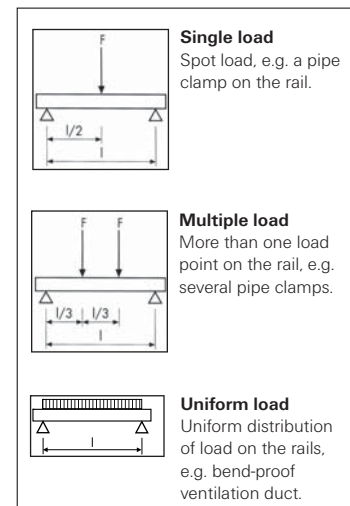

Mounting sprinkler systems

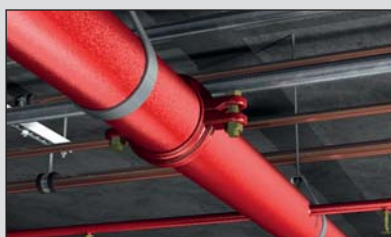

Sprinkler systems are usually created according to different standards. For example, according to the VdS standard (VdS CEA 4001), the American FM standard 1951 (Factory Mutual Insurance Company" (FM Global)), UL 203 (Underwriters Laboratories (UL)), NFPA 13 regulations (National Fire Protection Association (NFPA)) or EN 12845.

The European Directive CEA 4001 was created in 1995 by the insurance industry in cooperation with the manufacturers' association EUROFEU, and VdS CEA 4001 was created in Germany in 2003 by the "Association of Property Insurers" (VdS).

EN 12845 was developed on the basis of CEA 4001 from 1995 and the VdS CEA 4001 from 2003, creating a standard that was practically the same word for word. National practices, such as those for Germany, are to be included in a revised DIN 14489 as a national annex to EN 12845.

The American rules correspond to the requirements for mounting pipe installations, but they must be checked in detail in each case.

For mounting sprinkler pipes, the different load values, mounting distances and connection sizes for pipe loops and pipe clamps, which are listed in the following table for the most common directives, are applicable.

Pipe sizes	FM1951				NFPA13				VdS CEA 4001			
	Test load	Max. distance	Min rod size		Test load calculated	Max. distance	Min rod size		Loading capacity	Max. distance	Min rod size	
	[kN]	[m]	[metric]	[inch]	[kN]	[m]	[metric]	[inch]	[kN]	[m]	[metric]	[inch]
15	no data	no data	no data	no data	1.4	3.60	9.5	3/8	2.0	4.00	M8	no data
20	1.512	3.6	M10	3/8	1.5	3.60	9.5	3/8	2.0	4.00	M8	no data
25	1.824	3.6	M10	3/8	1.7	3.66	9.5	3/8	2.0	4.00	M8	no data
32	1.913	3.6	M10	3/8	1.9	3.66	9.5	3/8	2.0	4.00	M8	no data
40	2.313	4.6	M10	3/8	2.4	4.57	9.5	3/8	2.0	4.00	M8	no data
50	2.825	4.6	M10	3/8	2.9	4.57	9.5	3/8	3.5	4.00	M10	no data
65	4.181	4.6	M10	3/8	3.8	4.57	9.5	3/8	3.5	6.00	M10	no data
80	4.715	4.6	M10	3/8	4.8	4.57	9.5	3/8	3.5	6.00	M10	no data
90	5.583	4.6	M10	3/8	5.7	4.57	9.5	3/8	3.5	6.00	M10	no data
100	6.561	4.6	M10	3/8	6.7	4.57	9.5	3/8	5.0	6.00	M10	no data
125	8.896	4.6	M12	1/2	9.0	4.57	12.7	1/2	5.0	6.00	M12	no data
150	11.632	4.6	M12	1/2	11.8	4.57	12.7	1/2	8.5	6.00	M12	no data
200	16.903	4.6	M12	1/2	18.2	4.57	12.7	1/2	8.5	6.00	M16	no data
250	26.044	4.6	M16	5/8	26.7	4.60	15.9	5/8	no data	6.00	no data	no data

Pipe sizes	FM1951				NFPA13				VdS CEA 4001			
	Test load	Max. distance	Min rod size		Test load calculated	Max. distance	Min rod size		Loading capacity	Max. distance	Min rod size	
			[metric]	[inch]			[metric]	[inch]			[metric]	[inch]
DN	[kN]	[m]	[metric]	[inch]	[kN]	[m]	[metric]	[inch]	[kN]	[m]	[metric]	[inch]
300	35.141	4.6	M16	5/8	36.0	4.60	15.9	5/8	no data	6.00	no data	no data
350	no data	no data	no data	no data	42.9	4.60	no data	no data	no data	6.00	no data	no data
400	no data	no data	no data	no data	55.7	4.60	no data	no data	no data	6.00	no data	no data
450	no data	no data	no data	no data	70.1	4.60	no data	no data	no data	6.00	no data	no data
500	no data	no data	no data	no data	84.4	4.60	no data	no data	no data	6.00	no data	no data

Mounting gas pipes



A specification for the usable anchors emerged from the DVGW-TRGI revision in 2008. This is regulated in TRGI 2008 in Chapter II under item 5.3 "Preparation of pipe installations". In the TRGI from 2008, plastic anchors are now explicitly allowed under certain conditions.

The basis in the previous TRGI was the determination that gas pipes need to be mounted in the way that there are no free pipe cross-sections in the event of fire. In the new version, this was amended in that, in the event of fire, there may be no free pipe cross-sections up to a temperature of 650 °C. For pipe connections, this means that the axial restraint was also specified, and a brazed pipe joint, for example, is not considered as an axial restraint. Thus, standard commercially available plastic anchors with non-combustible pipe supports may be used for mounting metal inner pipes with an axial restraint of >650 °C. It should be noted that attachments are made to components with sufficient strength according to TRGI 2008. In addition, the mounting distances are governed in TRGI 2008, and are mandatory.

According to DVGW-TRGI 2008, plastic pipes for indoor pipes with an operating pressure up to 100 mbar are also allowed for the first time. For laying plastic inner pipes, in comparison to metal and non-combustible pipe installations, plastic pipes for gas installations are, without exception, subject to the system engagement of the manufacturer. The fixing materials for open gas pipes can also be made of plastic if the static requirements are met. The requirement for using plastic pipes in gas installations is the installation of a type K gas flow monitor in conjunction with an additional thermally activated shut-off device (TAE), as the destruction of the openly laid plastic gas pipes in the event of fire must be assumed.

Integration of rules regarding building classes according to the German model building regulations (MBO) was also implemented in DVGW TRGI 2008. An alignment of the fire protection requirements, which are specified in the German standard pipe systems directive (MLAR 2005) for the installation of pipes in buildings was, therefore, only logical. The limit for increased demands on the gas installation according to TRGI 2008 are > 2 utilisation units (building class 3) for buildings and for a floor level upper edge of more

than 7m of the top floor (building class 4). If any of these conditions exists, or if any of them are exceeded, it is not possible to lay plastic pipes in escape routes. For metal pipes, the requirements of MLAR 2005 for laying in installation channels or below plaster and plaster base are applicable. For pipe mounting with anchors, MLAR 2005 stipulates that either officially approved anchors are used or, alternatively, that the provisions of DIN4102-T.4, section 8.5.7.5 (or DIN EN 1366-1, section 13.6) are observed. The same rule also applies to the installation of pipes through officially approved partitions in walls and ceilings, as the mechanical destruction of the partitions by pipes in the event of fire must be prevented.

When installing gas pipes, we therefore recommend the use of approved metal anchors, since, through the general official approval and the European technical approval, the certificate of suitability for the anchor is provided, also for in the event of fire. This gives the installer the necessary safety, also at the limits.

Seismic and dynamic

The seismic and dynamic requirements for non-structural installations, such as pipe installations, are often underestimated in comparison to those of structural installations. But even here, the rule is that the weakest link in the chain can lead to failure or to damage.

Since basically every building in which such requirements, or additional requirements included by property insurers, such as FM, are different, it is also not possible to specify standard details. In addition, the solutions to be developed should also include the links to the components.

For this reason, we recommend everyone to use the support of our technical staff, in order to develop a suitable and project-specific solution.

www.fischer.de

Dimension and weights of pipes, ventilation ducts and ventilation pipes

Boiler pipe acc. to DIN 2448 / DIN EN 10220

DN	Size	Pipe outer- ϕ [mm]	Pipe weight empty [kg/m]	Pipe weight water filled [kg/m]	Pipe weight water filled + insulated ¹⁾ [kg/m]	Support widths [m]
8	1/4"	13.5	0.5	0.6	1.4	2.00
10	3/8"	17.2	0.7	0.8	1.9	2.25
15	1/2"	21.3	1.0	1.2	2.2	2.75
		25.0	1.1	1.5	2.8	2.75
20	3/4"	26.9	1.4	1.8	3.1	3.00
		30.0	1.8	2.3	4.0	3.00
		31.8	1.9	2.4	4.2	3.00
25	1"	33.7	2.0	2.6	4.7	3.50
		38.0	2.3	3.1	5.2	3.50
32	1 1/4"	42.4	2.6	3.7	5.7	3.75
		44.5	2.7	3.9	6.9	3.75
40	1 1/2"	48.3	3.0	4.4	7.4	4.25
		51.0	3.1	4.8	7.7	4.40
		57.0	3.9	6.0	10.0	4.60
50	2"	60.3	4.1	6.5	10.5	4.75
		63.5	4.4	7.0	11.0	4.75
		70.0	4.8	8.1	13.4	4.75
65	2 1/2"	76.1	5.3	9.2	14.8	5.50
		82.5	6.3	10.9	19.2	5.75
80	3"	88.9	6.8	12.2	20.4	6.00
		101.6	8.8	15.8	27.0	6.00
		108.0	9.3	17.3	29.1	6.00
100	4"	114.3	9.9	18.9	30.6	6.00
		127.0	12.2	23.3	36.1	6.00
		133.0	12.8	25.1	37.8	6.00
125	5"	139.7	13.5	27.1	40.3	6.00
		152.4	16.5	32.7	47.1	6.00
		159.0	17.3	34.9	49.2	6.00
		165.1	17.9	37.1	52.0	6.00
150	6"	168.3	18.3	38.2	53.0	6.00
		177.8	21.4	43.6	58.1	6.00
		193.7	25.2	51.5	68.0	6.00
200	8"	219.1	31.2	65.0	83.3	6.00
		244.5	37.2	79.5	98.6	6.00
		267.0	40.8	91.6	112.7	6.00
250	10"	273.0	41.6	94.9	117.7	6.00
300	12"	323.9	55.6	131.0	156.6	6.00

Stainless steel pipe acc. to DIN EN ISO 1127

DN	Size	Pipe outer- ϕ [mm]	Pipe weight empty [kg/m]	Pipe weight water filled [kg/m]	Pipe weight water filled + insulated ¹⁾ [kg/m]	Support widths [m]
10		17.2	0.6	0.8	1.8	1.3
15		21.3	1.0	1.2	2.3	1.5
20		26.9	1.3	1.7	2.9	2.0
25		33.7	1.6	2.3	4.3	2.3
32		42.4	2.0	3.2	5.2	2.8
40		48.3	2.3	3.9	6.8	3.0
50		60.3	2.9	5.4	9.5	3.5
65		76.1	3.7	7.8	13.5	4.3
80		88.9	4.4	10.0	18.2	4.8
100		114.3	7.3	16.6	28.3	5.0
125		139.7	8.9	23.1	36.4	5.0
150		168.3	13.2	34.1	48.9	5.0
200		219.1	17.3	52.8	71.2	5.0
250		273.0	21.6	80.1	100.9	5.0
300		323.9	25.7	108.1	132.0	5.0
400		406.4	32.3	162.0	190.6	5.0
500		508.0	40.4	243.1	279.8	5.0

¹⁾ Heat insulation: density 120 kg/m³ + sheet metal jacket: density 7865 kg/m³

²⁾ Heat insulation: density 120 kg/m³

The corresponding pipe manufacturer's data are to be considered.

Threaded pipe acc. to DIN 2440/DIN EN 10255

DN	Size	Pipe outer- ϕ [mm]	Pipe weight empty [kg/m]	Pipe weight water filled [kg/m]	Pipe weight water filled + insulated ¹⁾ [kg/m]	Support widths [m]
8	1/4"	13.5	0.7	0.7	1.6	2.00
10	3/8"	17.2	0.9	1.0	2.0	2.25
15	1/2"	21.3	1.2	1.4	2.5	2.75
20	3/4"	26.9	1.6	2.0	3.2	3.00
25	1"	33.7	2.4	3.0	5.1	3.50
32	1 1/4"	42.4	3.1	4.2	6.2	3.75
40	1 1/2"	48.3	3.6	5.0	8.0	4.25
50	2"	60.3	5.1	7.3	11.4	4.75
65	2 1/2"	76.1	6.5	10.2	15.9	5.50
80	3"	88.9	8.5	13.6	21.8	6.00
100	4"	114.3	12.1	20.8	32.5	6.00
125	5"	139.7	16.2	29.5	42.7	6.00
150	6"	165.1	19.2	38.2	53.1	6.00

Copper pipe acc. to DIN EN 1057

DN	Size	Pipe outer- ϕ [mm]	Pipe weight empty [kg/m]	Pipe weight water filled [kg/m]	Pipe weight water filled + insulated ²⁾ [kg/m]	Support widths [m]
8	10 x 1	10	0.3	0.3	0.4	1.00
10	12 x 1	12	0.3	0.4	0.5	1.25
12	15 x 1	15	0.4	0.5	0.8	1.25
15	18 x 1	18	0.5	0.7	1.0	1.50
20	22 x 1	22	0.6	0.9	1.3	2.00
25	28 x 1.5	28	1.1	1.6	2.4	2.25
32	35 x 1.5	35	1.4	2.2	3.1	2.75
40	42 x 1.5	42	1.7	2.9	4.4	3.00
50	54 x 2	54	2.9	4.9	7.3	3.50
	64 x 2	64	3.5	6.3	9.8	4.00
65	76.1 x 2	76.1	4.1	8.2	14.0	4.25
80	88.9 x 2	88.9	4.9	10.5	16.4	4.75
100	108 x 2.5	108	7.4	15.7	27.5	5.00

Stainless steel pressure system

DN	Size	Pipe outer- ϕ [mm]	Pipe weight empty [kg/m]	Pipe weight water filled [kg/m]	Pipe weight water filled + insulated ²⁾ [kg/m]	Support widths [m]
12	15 x 1	15	0.3	0.5	0.8	1.50
15	18 x 1	18	0.4	0.6	1.0	1.50
20	22 x 1.2	22	0.6	0.9	1.3	2.50
25	28 x 1.2	28	0.8	1.3	2.4	2.50
32	35 x 1.5	35	1.2	2.0	3.1	3.50
40	42 x 1.5	42	1.5	2.7	4.4	3.50
50	54 x 1.5	54	2.0	4.0	7.3	3.50
65	76.1 x 2	76.1	3.6	7.6	14.0	5.00
80	88.9 x 2	88.9	4.2	9.8	16.4	5.00
100	108 x 2	108	5.1	13.5	27.5	5.00

Metal composite pipe

DN	Size	Pipe outer- ϕ [mm]	Pipe weight empty [kg/m]	Pipe weight water filled [kg/m]	Pipe weight water filled + insulated ²⁾ [kg/m]	Support widths [m]
10	14 x 2	14	0.1	0.2	0.4	1.0
12	16 x 2.25	16	0.1	0.2	0.5	1.0
15	20 x 2.5	20	0.2	0.4	0.7	1.0
20	26 x 3	26	0.3	0.6	0.9	1.5
25	32 x 3	32	0.4	0.9	1.2	2.0
32	40 x 3.5	40	0.6	1.5	2.1	2.0
40	50 x 4	50	0.9	2.3	3.2	2.5
50	63 x 4.5	63	1.3	3.6	5.2	2.5

¹⁾ Heat insulation: density 120 kg/m³ + sheet metal jacket: density 7865 kg/m³ ²⁾ Heat insulation: density 120 kg/m³
The corresponding pipe manufacturer's data are to be considered.

Drain pipe, cast iron, SML, DIN EN 877

DN	Pipe outer- ϕ [mm]	Pipe weight empty [kg/m]	Pipe weight water filled [kg/m]	Support widths [m]
40	48	3.1	4.5	¹⁾
50	58	4.3	6.4	¹⁾
70	78	5.9	9.9	¹⁾
80	83	6.1	10.6	¹⁾
100	110	8.4	17.7	¹⁾
125	135	11.8	24.5	¹⁾
150	160	14.1	32.3	¹⁾
200	210	23.1	54.6	¹⁾
250	274	33.3	87.7	¹⁾
300	326	43.2	120.8	¹⁾
400	429	60.0	193.3	¹⁾
500	532	82.6	290.1	¹⁾

Drain pipe, PVC-U, DIN 8062

DN	Pipe outer- ϕ [mm]	Pipe weight empty [kg/m]	Pipe weight water filled [kg/m]	Support widths	
				20° [m]	40° [m]
40	50	0.8	1.3	0.8	0.6
50	63	1.3	2.0	1.1	0.7
65	75	1.8	3.9	1.3	0.8
80	90	2.6	3.9	1.3	0.8
100	110	3.9	8.0	1.6	1.0
125	125	5.0	12.4	1.8	1.1
150	160	8.2	18.0	2.2	1.2

LORO-X steel drain pipe

DN	Pipe outer- ϕ [mm]	Pipe weight empty [kg/m]	Pipe weight water filled [kg/m]	Support widths [m]
40	42	1.5	2.7	¹⁾
50	53	2.2	4.2	¹⁾
70	73	3.3	7.1	¹⁾
80	89	4.1	9.9	¹⁾
100	102	5.8	13.3	¹⁾
125	133	9.6	22.5	¹⁾
150	159	11.5	30.1	¹⁾
200	219	21.5	57.2	¹⁾
250	273	22.5	78.5	¹⁾
300	324	25.0	104.4	¹⁾

Drain pipe, GA, DIN 19500

DN	Pipe outer ϕ [mm]	Wall thickness [mm]	Pipe weight empty [kg/m]	Pipe weight water filled [kg/m]	Support widths [m]
50	60	3,5	5,19	7,39	¹⁾
70	80	3,5	7,02	11,21	¹⁾
100	112	4,0	11,33	19,83	¹⁾
125	137	4,0	13,96	27,03	¹⁾
150	162	5,0	20,59	38,74	¹⁾
200	212	6,0	32,42	63,84	¹⁾

Note:

The values for the max. support widths are based on the permissible deflection under load of the pipes and the corresponding recommendations from the pipe manufacturer. The permissible loads of the pipe fasteners and mountings are not taken into consideration.

¹⁾ approx. 1,50 m – 2,00 m.

According to the manufacturer's data, each pipe length should be supported in at least two places. The corresponding data from the pipe manufacturer are to be taken into consideration.

Drain pipe, PE, DIN 19535

DN	Pipe outer- \varnothing [mm]	Pipe weight empty [kg/m]	Pipe weight water filled [kg/m]	Support widths [m]
25	32	0.3	0.8	0.5
32	40	0.3	1.3	0.5
40	50	0.4	2.0	0.8
50	56	0.5	2.5	0.8
57	63	0.6	3.1	0.8
70	75	0.7	4.4	0.8
80	90	1.0	6.4	0.9
100	110	1.4	9.5	1.1
125	125	1.8	12.3	1.3
125	140	2.3	15.4	1.4
150	160	3.0	20.1	1.6
200	200	3.8	31.5	2.0
250	250	6.0	49.2	2.0

The weights in kg/m are reference values. The weights can deviate, depending on the sheet metal thickness and the type of flange used. The flange weight is included flat -rate. The loads based on a mineral wool weight of 80 kg/m² and a thickness of 5 cm.

Weights of galvanized ventilation ducts in kg/m without insulation

Sheet metal 0.75			Sheet metal 0.88							Sheet metal 1.0						Sheet metal 1.13					Sheet metal 1.25					◀ B	▶ H		
200	224	250	280	315	355	400	450	500	560	630	710	800	900	1000	1120	1250	1400	1600	1800	2000	2240	2500	2800	3150					
6.6	7.0	7.4	9.3	10.0	10.7	11.6	12.6	13.6	16.7	18.3	20.0	22.0	24.2	26.4	32.8	36.0	39.8	44.7	49.7	54.7	70.2	77.6	86.3	96.3	200				
	7.4	7.8	9.8	10.4	11.2	12.1	13.0	14.0	17.2	18.8	20.5	22.5	24.7	26.9	33.4	36.6	40.4	45.3	50.3	55.3	70.8	78.3	86.9	97.0	224				
		8.3	10.3	10.9	11.7	12.6	13.6	14.5	17.8	19.4	21.1	23.1	25.3	27.5	34.1	37.3	41.0	46.0	51.0	55.9	71.6	79.1	87.7	97.8	250				
			10.8	11.5	12.3	13.2	14.1	15.1	18.5	20.0	21.8	23.8	26.0	28.2	34.8	38.0	41.8	46.7	51.7	56.7	72.5	79.9	88.6	98.6	280				
				12.2	13.0	13.8	14.8	15.8	19.3	20.8	22.6	24.5	26.7	28.9	35.7	38.9	42.6	47.6	52.6	57.6	73.5	80.9	89.6	99.6	315				
					13.7	14.6	15.6	16.6	20.1	21.7	23.4	25.4	27.6	29.8	36.7	39.9	43.6	48.6	53.6	58.5	74.6	82.1	90.7	100.8	355				
						15.5	16.5	17.4	21.1	22.7	24.4	26.4	28.6	30.8	37.8	41.0	44.7	49.7	54.7	59.7	75.9	83.4	92.0	102.1	400				
							17.4	18.4	22.2	23.8	25.5	27.5	29.7	31.9	39.0	42.3	46.0	51.0	55.9	60.9	77.3	84.8	93.4	103.5	450				
								19.4	23.3	24.9	26.6	28.6	30.8	33.0	40.3	43.5	47.2	52.2	57.2	62.2	78.8	86.3	94.9	104.9	500				
									24.6	26.2	27.9	29.9	32.1	34.3	41.8	45.0	48.7	53.7	58.7	63.6	80.5	88.0	96.6	106.7	560				
										27.6	29.5	31.5	33.7	35.9	43.5	46.7	50.5	55.4	60.4	65.4	82.5	90.0	98.6	108.7	630				
											31.2	33.2	35.4	37.6	45.5	48.7	52.5	57.4	62.4	67.4	84.4	92.3	100.9	111.0	710				
												35.2	37.4	39.6	47.7	51.0	54.7	59.7	64.6	69.6	87.4	94.9	103.5	113.6	800				
													39.6	41.8	50.2	53.4	57.2	62.2	67.1	72.1	90.3	97.8	106.4	116.4	900				
														44.0	52.7	55.9	59.7	64.6	69.6	74.6	93.2	100.6	109.3	119.3	1000				
																55.7	58.9	62.6	67.6	72.6	91.6	98.6	107.2	117.2	1020				
																	62.2	65.9	70.9	75.8	95.8	102.8	111.4	121.4	1050				
																		69.6	74.6	79.6	99.6	106.6	115.2	125.2	1100				
																			79.6	84.5	89.5	110.4	117.9	127.9	1150				
																					89.5	94.5	116.2	123.6	133.6	1180			
																						99.4	121.9	129.4	139.4	1200			
																							128.8	136.3	146.3	1250			
																								143.8	153.8	163.8	1300		
																									161.0	171.1	1800		
																										181.5	191.5	2000	

Weights of galvanized ventilation ducts in kg/m with (80 kg/m³, 5 cm thickness)

Sheet metal 0.75			Sheet metal 0.88							Sheet metal 1.00							Sheet metal 1.13							Sheet metal 1.25					◀B	▶H
200	224	250	280	315	355	400	450	500	560	630	710	800	900	1000	1120	1250	1400	1600	1800	2000	2240	2500	2800	3150						
9.1	9.6	10.2	12.1	13.0	14.0	15.2	16.4	17.7	21.0	22.9	25.1	27.6	30.4	33.2	39.8	43.8	48.3	54.3	60.4	66.4	79.4	87.8	97.6	109.0	200					
	10.2	10.8	13.8	13.6	14.6	15.8	17.0	18.3	21.7	23.6	25.8	28.3	31.1	33.8	40.6	44.5	49.0	55.0	61.1	67.1	80.2	88.6	98.4	109.8	224					
		11.4	14.5	14.3	15.3	16.4	17.7	19.0	22.4	24.3	26.5	29.0	31.8	34.5	41.3	45.3	49.8	55.8	61.9	67.9	81.0	89.5	99.2	110.6	250					
			15.3	15.0	16.0	17.2	18.4	19.7	23.2	25.1	27.3	29.8	32.6	35.4	42.2	46.2	50.7	56.7	62.8	68.8	82.0	90.4	100.2	111.6	280					
				15.9	16.9	18.1	19.3	20.6	24.2	26.1	28.3	30.8	33.6	36.3	43.3	47.2	51.8	57.8	63.8	69.9	83.1	91.6	101.3	112.7	315					
					17.9	19.1	20.3	21.6	25.3	27.2	29.4	31.9	34.7	37.4	44.5	48.4	53.0	59.0	65.0	71.1	84.4	92.9	102.6	114.0	355					
						20.2	21.5	22.7	26.5	28.5	30.7	33.2	35.9	38.7	45.9	49.8	54.3	60.4	66.4	72.4	85.9	94.3	104.1	115.5	400					
							22.7	24.0	27.9	29.8	32.0	34.5	37.3	40.1	47.4	51.3	55.8	61.9	67.9	73.9	87.5	96.0	105.7	117.1	450					
								25.3	29.3	31.2	33.4	35.9	38.7	41.4	48.9	52.8	57.3	63.4	69.4	75.4	89.1	97.6	107.4	118.7	500					
									30.9	32.9	35.1	37.6	40.3	43.1	50.7	54.6	59.1	65.2	71.2	77.3	91.1	99.5	109.3	120.7	560					
										34.8	37.0	39.5	42.3	45.0	52.8	56.7	61.3	67.3	73.3	79.4	93.4	101.8	111.6	123.0	630					
											39.2	41.7	44.5	47.2	55.2	59.1	63.7	69.7	75.7	81.8	96.0	104.4	114.2	125.6	710					
												44.2	47.0	49.7	57.9	61.9	66.4	72.4	78.5	84.5	98.9	107.4	117.1	128.5	800					
													49.7	52.5	61.0	64.9	69.4	75.4	81.5	87.5	102.1	110.6	120.4	131.8	900					
																55.3	60.0	67.0	72.4	78.5	90.5	105.4	113.9	123.6	135.0	1000				
																	67.6	71.5	76.0	82.1	88.1	94.1	109.3	117.8	127.5	138.9	1120			
																		75.4	80.0	86.0	92.0	98.1	113.5	122.0	131.8	143.1	1250			
																			84.5	90.5	96.6	102.6	118.4	126.9	136.6	148.0	1400			
																				96.6	102.6	108.6	124.9	133.4	143.1	154.5	1600			
																					108.6	114.7	131.4	139.9	149.6	161.0	1800			
																						120.7	137.9	146.4	156.2	167.5	2000			
																							145.7	154.2	164.0	175.3	2240			
																								162.7	172.4	183.8	2500			
																									182.2	193.6	2800			
																										204.9	3150			

Spiral lock seam pipe, round, acc. to DIN EN12237

DN	71	80	90	100	112	125	140	150	160	180	200	224	250	280	300	315	355	400	450	500	560	600	630	710	800	900	1000	1120	1250
Pipe outer Ø [mm]	75	84	94	105	117	130	145	155	165	185	205	229	255	285	307	322	362	407	457	507	567	609	639	719	810	1012	1012	1132	1262
Sheet thickness [mm]	0.4	0.4	0.4	0.6	0.6	0.6	0.6	0.6	0.6	0.6	0.6	0.6	0.6	0.6	0.8	0.8	0.8	0.8	0.8	0.8	0.8	1.0	1.0	1.0	1.0	1.0	1.2	1.2	1.2
Pipe weight empty [kg/m]	0.8	0.9	1.0	1.7	1.9	2.1	2.4	2.6	2.7	3.1	3.4	3.8	4.2	4.7	5.2	7.1	8.0	9.0	10.2	11.3	12.6	13.5	17.7	20.0	22.5	25.4	34.9	39.1	43.7

Important dimensions, variables and units

Comparison of material standards

DIN EN ISO			ASTM
Description	Material-No.		
S 250 GD+Z	1.0242	EN 10027-2	A 653
DD11	1.0332	DIN EN 10111	A 621 CQ
DC01	1.0330	DIN EN 10130	A 366
St 22	1.0320	DIN 1614-1	n/a
DX51D+Z 275 NA-C	1.0226+Z	DIN EN 10327	A 653/CQ
S235JR	1.0037	DIN EN 10025	A 283
S 355 MC	1.0976	DIN EN 10149	n/a
4.6 ; 4.8	DIN EN ISO 898-1		F 568M

Variables and units

Size	Formula symbol	Unit SI	others	related	Note
Length	l	m		1 m = 10 dm = 100 cm = 1.000 mm 1 mm = 1.000 µm 1 km = 1.000 m	1 inch = 1 Zoll = 25.4 mm
Area	A, S	m ²	a, ha	1 m ² = 10.000 cm ² = 1.000.000 m ² 1 a = 100 m ² 1 ha = 100 a = 10.000 m ²	
Volume	V	m ³	l	1 m ³ = 1.000 dm ³ = 1.000.000 cm ³ 1 l = 1 dm ³ = 0.001 m ³ 1 ml = 1 cm ³	
Time	t	s	min, h, d	1 min = 60 s 1 h = 60 min = 3.600 s 1 d = 24 h	
Frequency	f	Hz		1 Hz = 1/s	
Speed	v	m/s	m/s, km/h	1 m/s = 3.6 km/h	
Acceleration	a, g	m/s ²		g = 9.81 m/s ²	Formula symbol g for gravity only
Weight	m	kg	g, t	1 kg = 1.000 g 1 t = 1.000 kg	
Density	ρ	kg/m ³		1.000 kg/m ³ = 1 t/m ³ = 1 kg/dm ³	
Moment of inertia, 2 nd degree	J	kg • m ²			Previously: mass moment of inertia
Force	F	N		1 N = 1 kg • m/s ²	Previously: kp (Kilopond) 1 kp = 9.80665 kgm/s ² = 9.81 N
Torque	M	N • m			
Bending moment	M _b	N • m			
Torsion moment	T	N • m			
Mechanical tension	σ, τ	N/m ²			
Area-wise moment, 2 nd degree	I	m ⁴			Previously: area moment of inertia
Energy, work	E, W	J		1 J = 1 N • m = 1 W • s	in former times: cal (Calorie) 1 cal = 4.1868 Ws = 4.19 J
Power	P	W		1 W = 1 J/s = 1 N • m/s	in former times: PS (Horse power) 1 PS = 75 kpm/s = 75 • 9.81 N/ms = 0.736 kW
Thermodynamic temperature	T	K		0 °C = 273 K; -273 C = 0 K	
Heat quantity	Q	J	(Wh)	1 J = 1 W • s = 1 N • m	
Specific heat value	H	J/kg			
Substance quantity	n	mol		1 mol corresponds to approx. 6 • 10 ²³	
Light intensity	I _v	cd			

Approvals, markings and their importance

In the following, excerpts of approvals that are currently issued in Europe and their symbols will be given with their corresponding importance:

Please check whether your application is safety relevant.

An application is safety relevant when failure of anchorages would cause risk to human life or serious injuries and/or lead to considerable economic consequences. In this case please use anchors with a European Technical (ETA) or with a German Approval. You may recognise these anchors by:



European Technical Approval
issued by a European approval authority (e.g. DIBt) on the basis of the guidelines for European technical approvals (ETAG)
ETA: European Technical Approval/ Options 1 – 12
CE: European conformity mark confirms the compliance of the building product (e.g. fixing) with the guidelines for European Technical Approvals. Products with the CE mark can be freely traded in the European economic market.



Additional information about seismic performance is given for approval anchor system below the ETA sign.



General building authority approval

German approval, issued by the DIBt, Berlin for anchorings in concrete to be dimensioned according to Method A (CC method). Proof of compliance of the building product with the general building authority approval. confirmed by a material testing facility.



ICC = International Code Council, formed from BOCA, ICBO and SBCCI

ICC Evaluation Service Inc. (ICC ES) issues evaluation reports, in this case for the above anchor based upon the Uniform Building Code™ and related codes in the United States of America.



General building authority approval

German approval, issued by the DIBt, Berlin. Proof of compliance of the building product with the general building authority approval. confirmed by a material testing facility.



FM Certificate

Recognised for use in local water-based fire extinguisher systems (Factory Mutual Research Corporation for Property Conservation, American insurance company).



VdS-Certificate

Recognised for the use in local water-based fire extinguisher systems (formerly: Association of Property Insurers, now: VdS Damage Prevention)

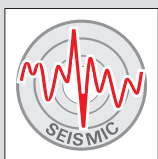

The anchor system is suitable for loads under seismic action.



Fire behaviour tested according temperature - time curve of ZTV-ING: 2003-1, part 5 tunnel.



Biobased 50-85%, tested by
DIN CERTCO/ TÜV Rheinland.



Fire behaviour tested according
Rijkswaterstaat (RWS) time -
temperature curve.



Fixing of high-quality,
aging-resistant **nylon** (polyamide).

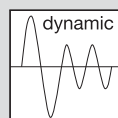

**Fixing that can be dynamically
loaded**

The fixing is suitable and approved
for anchoring of "not predominantly
static" (i.e. dynamic) loads.



The material of fixing element is
Halogen free.

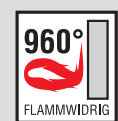

Tested for **flame resistance**
according to VDE.

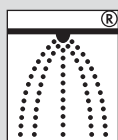

For **Sprinkler Systems**.
Meets the requirements according to
VdS CEA 4001.

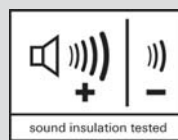

**Sound insulation tested
according DIN 4109**

The product was subjected to a
sound insulation test. A "measure-
ment of the insertion loss" is availa-
ble in a test report.



Fire-tested product MLAR
The product was subjected to a fire
test. A "Examination report regard-
ing testing according the german
Muster-Leitungsanlagenrichtlinie
(MLAR) is available.



Fire-tested product MLAR
The product was subjected to a fire
test. A "Examination report regard-
ing testing according the german
Muster-Leitungsanlagenrichtlinie
(MLAR) is available.



Fire-tested fixing
The fixing or installation product was
subjected to a fire test.
A "Examination report regarding
testing for fire behaviour" according
EN 13501 (with R class) is available.



Fire-tested fixing
The fixing was subjected to a fire test.
A "Examination report regarding test-
ing for fire behaviour" (with R class)
is available.



**Fire-tested product DIN EN
1366-1**
The product was subjected to a fire
test. A "Examination report" accord-
ing DIN EN 16366-1 is available.



Fire-tested product DIN 4102-2
The product was subjected to a fire
test. A "Examination report" accord-
ing DIN 4102-2 is available.

Advantage for professionals:

The fischer International Catalogue offers lots of facts and helps with fast and secure product selection. Over 300 pages of Product descriptions with advantages/benefits overview

- Installation tips
- Application aids
- Detailed technical data
- Fundamentals of fastening technology

In short: everything that the professional needs to know about fastening.

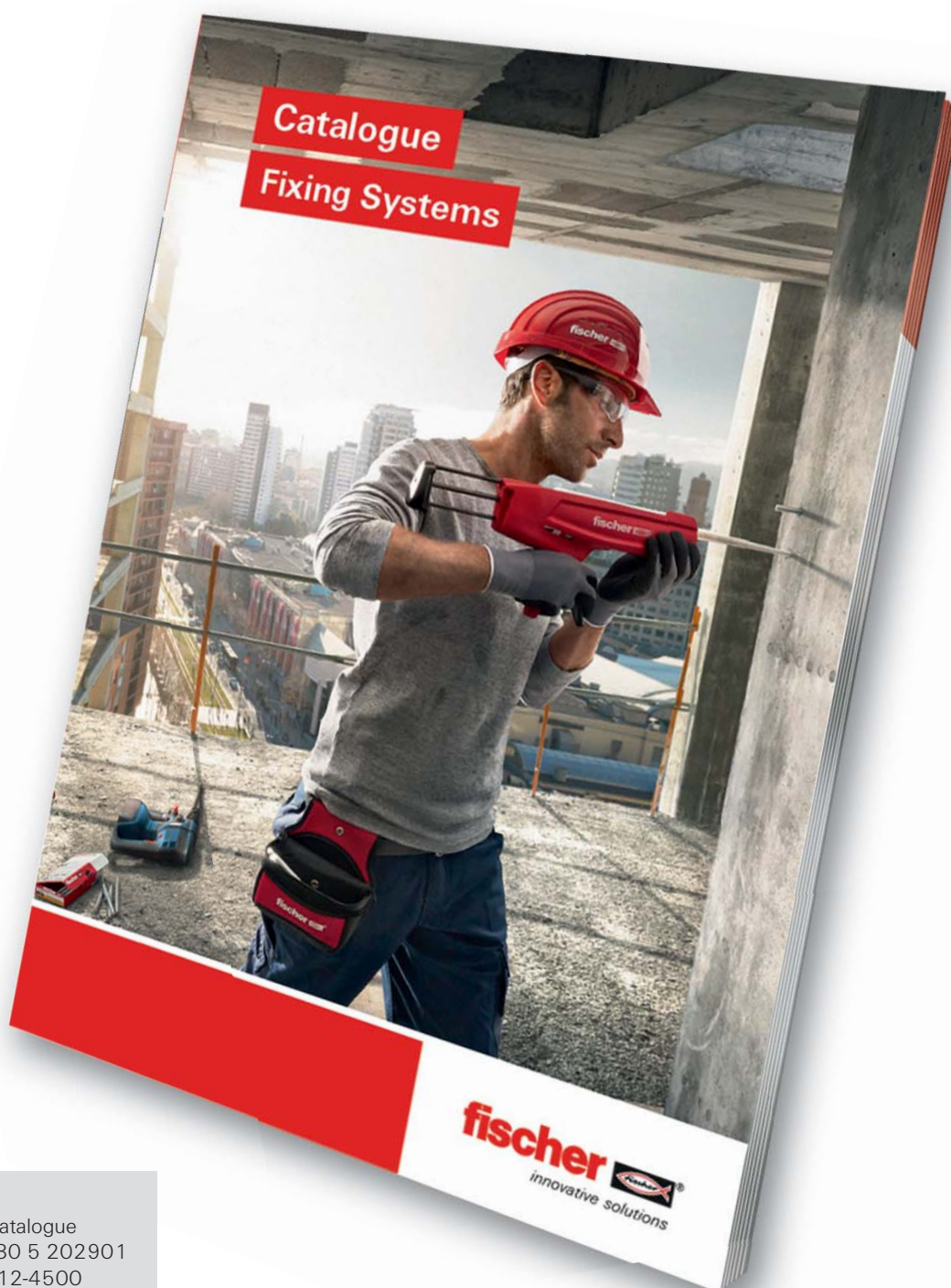

Don't wait. Start!
Request a international catalogue
on the Hotline +49(0) 180 5 202901
or by fax +49 (0) 7443 12-4500



2

PIPE CLAMPS

	page		page
Single screw pipe clamps		Heavy duty pipe clamps	
Hinged pipe clamp FGRS Plus	48	Heavy duty pipe clamp FRSM - inch	68
Hinged pipe clamp FGRS	50	Heavy duty pipe clamp FRSM - metric	70
Hinged pipe clamp FKS Plus for plastic pipes	52	Insulated pipe clamps	
Two screw pipe clamps		Refrigeration pipe clamp FRS K	72
Pipe clamp FRS Plus	54	Refrigeration pipe clamp KFT	74
Pipe clamp FRS-L Universal	56	Sprinkler clamps	
Pipe clamp FRS Triple	58	Sprinkler clamp FRSP	78
Pipe clamp FRS	60	Sprinkler clamp FRSL	80
Silicone pipe clamp FRSH	62	Others	
Pipe clamp FRSN Triple	64	U-Clamp FUBD	82
Pipe clamp FRSN	66	U-bolt ETR	77
		Hose clamp SGS	84

The one-piece hinged pipe clamp with rapid-locking mechanism

2

Pipe clamps



Light, suspended pipelines



Pipelines on cantilevers

APPLICATIONS

- Time-saving fixing for pipes up to Ø2" using threaded rods or stud screws

ADVANTAGES/BENEFITS

- The rapid-locking mechanism allows a fast and time-saving installation.
- The tight fit of the sound insulation insert prevents it from falling out when inserting the pipe.
- The safety latch fastening guarantees pipe installation without the clamp springing open.
- The combination connecting nut with M8/M10 thread on the FGRS Plus M8/M10 allows optimised mounting choices.
- The screw's combination cross-drive thread allows flexibility during the installation process.
- The compact construction of the pipe clamp enables a simple post-installation insulation.

PROPERTIES

- **Material:** steel DC01 (material no. 1.0330) acc. to DIN EN 10130
- **Zinc plating:** electro zinc-plated, 5 - 9 µm
- **Connecting nut:** resistance welded, SW 13
- **Locking screw:** flat head screw with combination recessed head
- **Material sound insulation insert:** SBR/EPDM; chlorine-free; silicone-free
- **Sound insulation:** for DIN 4109
- **Temperature range:** -40 °C to +100 °C
- **Hardness:** 55 ± 5° Shore A
- **Fire behaviour:** DIN 4102: Class B2

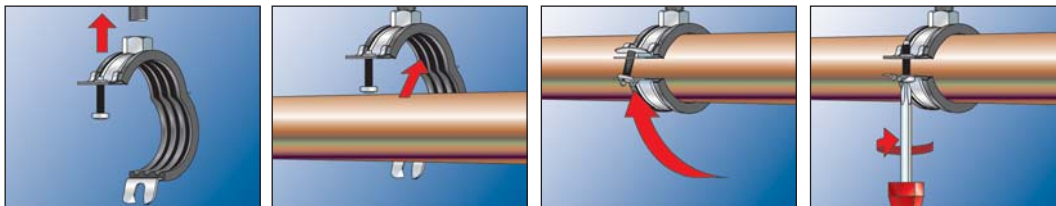

TECHNICAL DATA

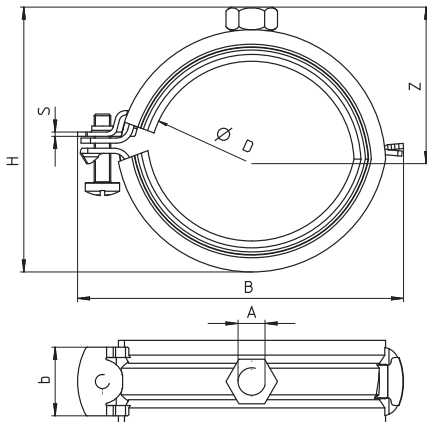

Item	Art.-No.	Thread	Size	Clamping range	Width B	Height H	Width x thickness clamp band	Height Z	Locking screw	Max. recom. static load (centr. tension) N _{recom.} [kN]	Sales unit [pcs]
		A	[inch]	D [mm]	B [mm]	H [mm]	b x s [mm]	Z [mm]			
FGRS Plus 12 - 14	079400	M 8	1/4"	12 - 14	48	35	20 x 1,25	21	M 5	0.65	100
FGRS Plus 15 - 19	079401	M 8	3/8"	15 - 19	52	40	20 x 1,25	24	M 5	0.65	100
FGRS Plus 20 - 24	079402	M 8	1/2"	20 - 24	58	45	20 x 1,25	26	M 5	0.65	100
FGRS Plus 25 - 30	079403	M 8	3/4"	25 - 30	63	49	20 x 1,25	28	M 5	0.65	100
FGRS Plus 32 - 37	079404	M 8	1"	32 - 37	72	57	20 x 1,25	32	M 5	0.65	100
FGRS Plus 40 - 44	079405	M 8	1 1/4"	40 - 44	79	66	20 x 1,5	37	M 5	0.90	50
FGRS Plus 45 - 50	079406	M 8	1 1/2"	45 - 50	88	76	20 x 1,5	42	M 5	0.90	50
FGRS Plus 50 - 55	079407	M 8	—	50 - 55	94	82	20 x 1,5	45	M 5	0.90	50
FGRS Plus 56 - 63	079408	M 8	2"	56 - 63	99	85	20 x 1,5	46	M 5	0.90	50

TECHNICAL DATA

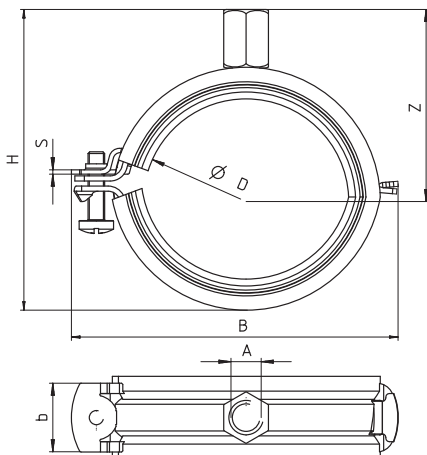

Item	Art.-No.	Thread	Size	Clamping range	Width B	Height H	Width x thickness clamp band	Height Z	Locking screw	Max. recom. static load (centr. tension) N _{recom.} [kN]	Sales unit [pcs]
		A	[inch]	D [mm]	B [mm]	H [mm]	b x s [mm]	Z [mm]			
FGRS Plus 12 - 14 M8/M10	079430	M 8 / M 10	1/4"	12 - 14	48	46	20 x 1,25	31	M 5	0.65	100
FGRS Plus 15 - 19 M8/M10	079431	M 8 / M 10	3/8"	15 - 19	52	51	20 x 1,25	34	M 5	0.65	100
FGRS Plus 20 - 24 M8/M10	079432	M 8 / M 10	1/2"	20 - 24	58	56	20 x 1,25	36	M 5	0.65	100
FGRS Plus 25 - 30 M8/M10	079433	M 8 / M 10	3/4"	25 - 30	63	60	20 x 1,25	38	M 5	0.65	100
FGRS Plus 32 - 37 M8/M10	079434	M 8 / M 10	1"	32 - 37	72	68	20 x 1,25	42	M 5	0.65	100
FGRS Plus 40 - 44 M8/M10	079435	M 8 / M 10	1 1/4"	40 - 44	79	76	20 x 1,5	47	M 5	0.90	50
FGRS Plus 45 - 50 M8/M10	079436	M 8 / M 10	1 1/2"	45 - 50	88	86	20 x 1,5	52	M 5	0.90	50
FGRS Plus 50 - 55 M8/M10	079437	M 8 / M 10	—	50 - 55	94	92	20 x 1,5	55	M 5	0.90	50
FGRS Plus 56 - 63 M8/M10	079438	M 8 / M 10	2"	56 - 63	99	95	20 x 1,5	56	M 5	0.90	50

The one-piece hinged pipe clamp with floating single screw

2
Pipe clamps



Fixation with multi-connector



Leightweight installation on cantilever

APPLICATIONS

- For economical fixing of pipes up to Ø2" with threaded rods or stud screws

ADVANTAGES/BENEFITS

- The floating single screw allows a simple, one-handed installation.
- The safety latch fastening guarantees secure pipe installation without the clamp springing open.
- The compact construction of the pipe clamp enables a simple post-installation insulation.
- The screw's design stops it falling out during the installation.

PROPERTIES

- **Material:** steel DD11 (material no. 1.0332) acc. to DIN EN 10111
- **Zinc plating:** electro zinc-plated, 5 - 9 µm
- **Connecting nut:** resistance welded, M8, SW 13
- **Locking screw:** flat head screw with combination recessed head
- **Material sound insulation insert:** EPDM; chlorine-free; silicone-free
- **Sound insulation:** for DIN 4109
- **Temperature range:** -40 °C to +100 °C
- **Hardness:** 55 ± 5° Shore A
- **Fire behaviour:** DIN 4102: Class B2

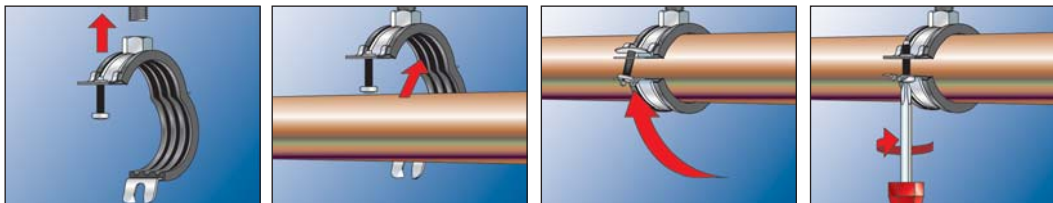

TECHNICAL DATA

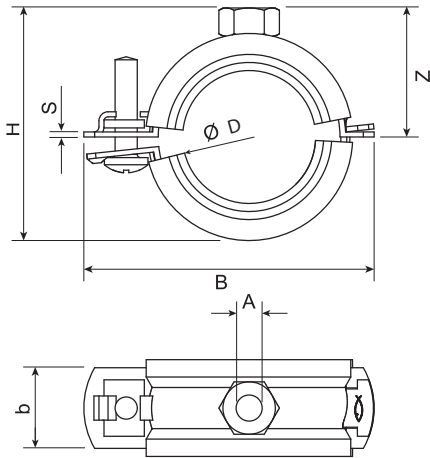

Item	Art.-No.	Thread A	Size [inch]	Clamping range D [mm]	Width B B [mm]	Height H H [mm]	Width x thickness clamp band b x s [mm]	Height Z Z [mm]	Locking screw	Max. recom. static load (centr. tension) N _{recom.} [kN]	Sales unit [pcs]
FGRS 8 - 11	537212	M 8	–	8 - 11	45	29	20 x 1,25	17	M 5	0.80	100
FGRS 12 - 14	079420	M 8	1/4"	12 - 14	48	31	20 x 1,25	21	M 5	0.80	100
FGRS 15 - 19	079421	M 8	3/8"	15 - 19	52	36	20 x 1,25	24	M 5	0.80	100
FGRS 20 - 24	079422	M 8	1/2"	20 - 24	58	41	20 x 1,25	26	M 5	0.80	100
FGRS 25 - 30	079423	M 8	3/4"	25 - 30	63	47	20 x 1,25	28	M 5	0.80	100
FGRS 32 - 37	079424	M 8	1"	32 - 37	72	54	20 x 1,25	32	M 5	0.80	100
FGRS 40 - 44	079425	M 8	1 1/4"	40 - 44	79	61	20 x 1,5	37	M 5	0.90	50
FGRS 45 - 50	079426	M 8	1 1/2"	45 - 50	88	67	20 x 1,5	42	M 5	0.90	50
FGRS 50 - 55	079427	M 8	–	50 - 55	94	72	20 x 1,5	45	M 5	0.90	50
FGRS 56 - 63	079428	M 8	2"	56 - 63	99	80	20 x 1,5	46	M 5	0.90	50

The one-screw hinged pipe clamp with quick-release fastener for plastic and metal composite pipes

2

Pipe clamps



Plastic pipe with fixpoint installation

APPLICATIONS

- Time-saving fixing for plastic and metal composite pipes using threaded rods or stud screws
- Can be used as a slide bracket with spacers or as a fixed point clamp by removing the spacers

ADVANTAGES/BENEFITS

- The quick-release fastener allows a fast and time-saving installation.
- The spacing sleeves on the locking screw stops over tightening of the pipes.
- The tight fit of the sound insulation insert prevents it from falling out when inserting the pipe.
- The latch fastening guarantees pipe installation without the clamp springing open.
- The compact construction of the hinged pipe clamp enables a simple post-installation insulation.
- The screw's design stops it falling out during the installation.

PROPERTIES

- **Material:** steel DD11 (material no. 1.0332) acc. to DIN EN 10111
- **Zinc plating:** electro zinc-plated, 5 - 9 µm
- **Connecting nut:** resistance welded, M8, SW 13
- **Locking screw:** flat head screw with combination recessed head
- **Material sound insulation insert:** NR/SBR/EPDM; chlorine-free; silicone-free
- **Sound insulation:** for DIN 4109
- **Temperature range:** -40 °C to +110 °C
- **Hardness:** 60 ± 5° Shore A
- **Fire behaviour:** DIN 4102: Class B2

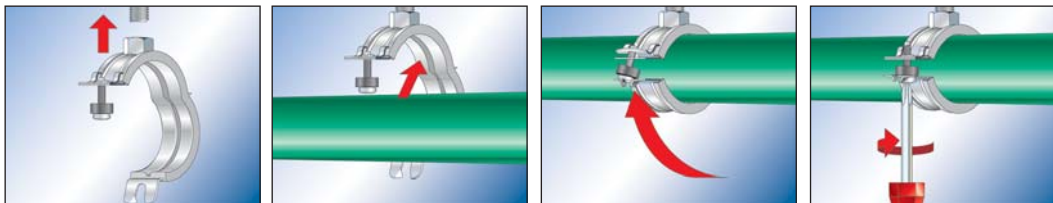

TECHNICAL DATA

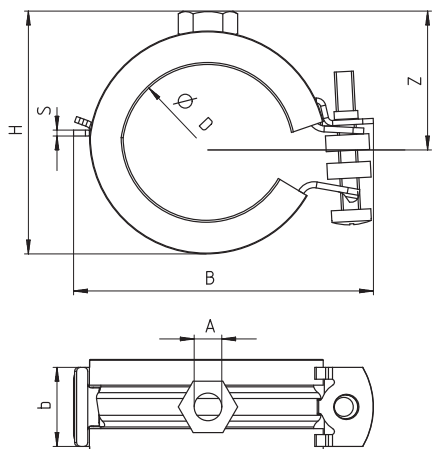

Item	Art.-No.	Thread	Size	Clamping range	Width B	Height H	Width x thickness clamp band	Height Z	Locking screw	Max. recom. static load (centr. tension) N _{recom.} [kN]	Sales unit [pcs]
		A	[inch]	D [mm]	B [mm]	H [mm]	b x s [mm]	Z [mm]			
FKS Plus 15 - 19	079470	M 8	3/8"	15 - 19	52	40	20 x 1,25	24	M 5	0.65	100
FKS Plus 20 - 24	079471	M 8	1/2"	20 - 24	58	45	20 x 1,25	26	M 5	0.65	100
FKS Plus 25 - 30	079472	M 8	3/4"	25 - 30	63	49	20 x 1,25	28	M 5	0.65	100
FKS Plus 32 - 37	079473	M 8	1"	32 - 37	72	57	20 x 1,25	32	M 5	0.65	100
FKS Plus 40 - 44	079474	M 8	1 1/4"	40 - 44	79	66	20 x 1,5	37	M 5	0.90	50
FKS Plus 45 - 50	079475	M 8	1 1/2"	45 - 50	88	76	20 x 1,5	42	M 5	0.90	50
FKS Plus 50 - 55	079476 ¹⁾	M 8	—	50 - 55	94	82	20 x 1,5	45	M 5	0.90	50
FKS Plus 56 - 63	079477	M 8	2"	56 - 63	99	85	20 x 1,5	46	M 5	0.90	50

1) Delivery on request.

The two-screw pipe clamp with rapid-locking mechanism

2
Pipe clamps

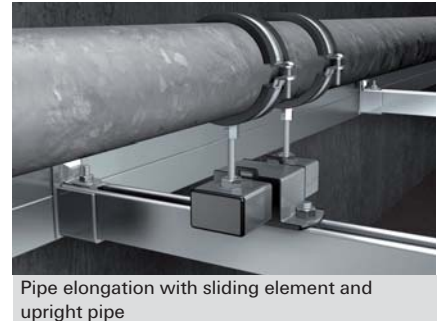

APPLICATIONS

- For simple and easy fixing of pipes using threaded rods or stud screws

ADVANTAGES/BENEFITS

- The rapid-locking mechanism allows for fast and time-saving installation.
- The safety latch fastening guarantees pipe installation without the clamp springing open.
- The tight fit of the sound insulation insert prevents it from falling out when aligning the pipe.
- The combination connecting nut with M8/M10 thread enables optimised mounting choices.
- The two screws allow an easy adjustment to suit the outer pipe diameter.
- The screw's safety feature ensures trouble-free installation.

CERTIFICATES

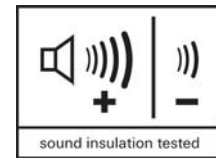

PROPERTIES

- **Material:** steel DC01 (material no. 1.0330) acc. to DIN EN 10130
- **Zinc plating:** electro zinc-plated, 5 - 9 µm
- **Connecting nut:** resistance welded, M8 / M10, SW 13
- **Locking screw:** flat head screw with combination recessed head
- **Material sound insulation insert:** EPDM; chlorine-free; silicone-free
- **Sound insulation:** for DIN 4109
- **Temperature range:** -40 °C to +100 °C
- **Hardness:** 55 ± 5° Shore A
- **Fire behaviour:** DIN 4102: Class B2

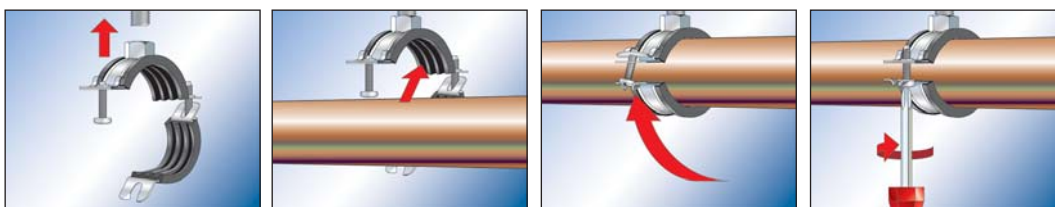

TECHNICAL DATA

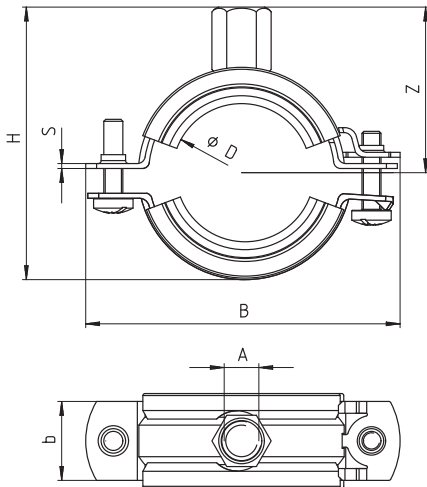

Item	Art.-No.	Thread	Size	Clamping range	Width B	Height H	Width x thickness clamp band	Height Z	Locking screw	Max. recom. static load (centr. tension) N _{recom.} [kN]	Sales unit [pcs]
		A	[inch]	D [mm]	B [mm]	H [mm]	b x s [mm]	Z [mm]			
FRS Plus 12 - 15	079440	M 8 / M 10	1/4"	12 - 15	59	41	20 x 1,25	28	M 5	0.80	100
FRS Plus 15 - 19	079441	M 8 / M 10	3/8"	15 - 19	63	45	20 x 1,25	30	M 5	0.80	100
FRS Plus 20 - 24	079442	M 8 / M 10	1/2"	20 - 24	68	50	20 x 1,25	32	M 5	0.80	100
FRS Plus 25 - 30	079443	M 8 / M 10	3/4"	25 - 30	74	56	20 x 1,25	35	M 5	0.80	100
FRS Plus 32 - 37	079444	M 8 / M 10	1"	32 - 37	81	63	20 x 1,25	39	M 5	0.80	100
FRS Plus 40 - 45	079445	M 8 / M 10	1 1/4"	40 - 45	90	71	20 x 1,5	43	M 5	1.00	50
FRS Plus 48 - 54	079446	M 8 / M 10	1 1/2"	48 - 54	98	80	20 x 1,5	48	M 5	1.00	50
FRS Plus 55 - 61	079447	M 8 / M 10	2"	55 - 61	100	87	20 x 1,5	51	M 5	1.00	50
FRS Plus 63 - 67	079449	M 8 / M 10	–	63 - 67	114	93	20 x 1,5	54	M 5	1.00	25
FRS Plus 68 - 73	079450	M 8 / M 10	–	68 - 73	117	100	20 x 2,0	58	M 6	1.80	25
FRS Plus 72 - 80	079451	M 8 / M 10	2 1/2"	72 - 80	125	107	20 x 2,0	61	M 6	1.80	25
FRS Plus 80 - 86	079452	M 8 / M 10	–	80 - 86	132	113	20 x 2,0	64	M 6	1.80	25
FRS Plus 87 - 92	079453	M 8 / M 10	3"	87 - 92	139	119	20 x 2,0	67	M 6	1.80	25
FRS Plus 95 - 103	079454	M 8 / M 10	–	95 - 103	151	130	20 x 2,0	73	M 6	1.80	25
FRS Plus 108 - 116	079455	M 8 / M 10	4"	108 - 116	163	143	20 x 2,0	79	M 6	1.80	20

The light two-screw pipe clamp with rapid-locking mechanism and combination connecting nut

2
Pipe clamps



Cantilever construction with channel



Vertical installation

APPLICATIONS

- For simple and easy fixing for pipes using threaded rods or stud screws

ADVANTAGE/BENEFITS

- The fire inspection report and the sound insulation report guarantee objectively tested functional safety.
- The unique rapid-locking mechanism with crimped edges allows a secure and time-saving installation.
- The clamp band with crimped edges gives a tight fit of the sound insulation insert and prevents it from slipping out when aligning the pipe.
- The two screws allow a perfect adaptation of the pipe clamp to suit every outer pipe diameter.
- The connecting nut with combination thread M8/M10 enables an optimised warehousing.
- The screw's loss protection guarantees an easy installation.

CERTIFICATES

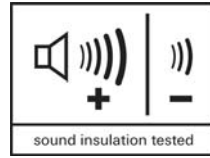
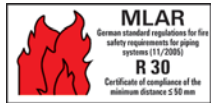

PROPERTIES

- **Material:** steel DD11 (material no. 1.0332) acc. to DIN EN 10111
- **Zinc plating:** electro zinc-plated, min. 5 µm acc. DIN EN ISO 4042
- **Connecting nut:** resistance welded, M8 / M10, SW 13
- **Locking screw:** flat head screw with combination recessed head
- **Material sound insulation insert:** SBR/EPDM; chlorine-free; silicone-free
- **Sound insulation:** for DIN 4109
- **Temperature range:** -40 °C to +100 °C
- **Hardness:** 55 ± 5° Shore A
- **Fire behaviour:** DIN 4102: Class B2

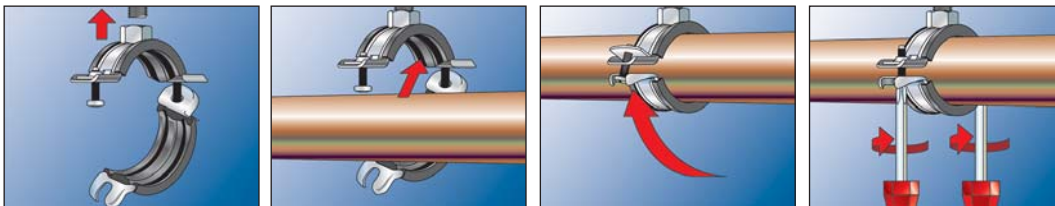

TECHNICAL DATA

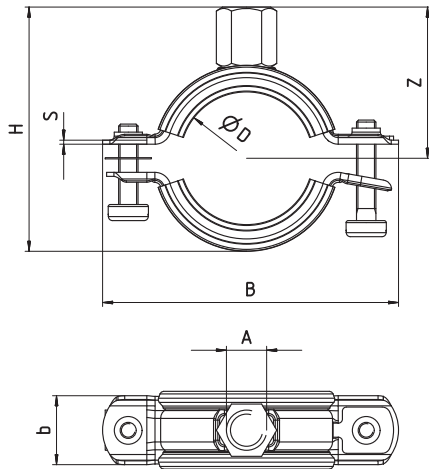

Item	Art.-No.	Fire test report	Thread	Size	Clamping range	Width B	Height H	Width x thickness clamp band	Height Z	Locking screw	Max. recom. static load (centr. tension) N _{recom.} [kN]	Sales unit [pcs]
			A	[inch]	D [mm]	B [mm]	H [mm]	b x s [mm]	Z [mm]			
FRS-L 8 - 11 Universal	539443	X	M 8 / M 10	–	8 - 11	47	35	18 x 1,0	25	M 5	0.70	25
FRS-L 12 - 15 Universal	539444	X	M 8 / M 10	1/4"	12 - 15	52	39	18 x 1,0	27	M 5	0.70	25
FRS-L 16 - 19 Universal	539445	X	M 8 / M 10	3/8"	16 - 19	56	43	18 x 1,0	29	M 5	0.70	25
FRS-L 20 - 24 Universal	539446	X	M 8 / M 10	1/2"	20 - 24	61	48	18 x 1,0	31	M 5	0.70	25
FRS-L 25 - 30 Universal	539447	X	M 8 / M 10	3/4"	25 - 30	67	53	18 x 1,0	34	M 5	0.70	25
FRS-L 31 - 37 Universal	539448	X	M 8 / M 10	1"	31 - 37	74	61	18 x 1,0	38	M 5	0.70	25
FRS-L 38 - 45 Universal	539449	X	M 8 / M 10	1 1/4"	38 - 45	83	69	18 x 1,2	42	M 5	1.00	25
FRS-L 46 - 52 Universal	539450	X	M 8 / M 10	1 1/2"	46 - 52	90	76	18 x 1,2	45	M 5	1.00	25
FRS-L 53 - 59 Universal	539451	X	M 8 / M 10	–	53 - 59	97	83	18 x 1,2	49	M 5	1.00	25
FRS-L 60 - 66 Universal	539452	X	M 8 / M 10	2"	60 - 66	104	90	18 x 1,2	52	M 5	1.00	10
FRS-L 67 - 75 Universal	539453	X	M 8 / M 10	–	67 - 75	120	100	20 x 1,8	57	M 6	1.50	10
FRS-L 76 - 84 Universal	539454	X	M 8 / M 10	2 1/2"	76 - 84	130	109	20 x 1,8	62	M 6	1.50	10
FRS-L 85 - 93 Universal	539455	X	M 8 / M 10	3"	85 - 93	139	118	20 x 1,8	66	M 6	1.50	10
FRS-L 94 - 100 Universal	539456	X	M 8 / M 10	–	94 - 100	146	125	20 x 1,8	70	M 6	1.50	10
FRS-L 101 - 110 Universal	539457	X	M 8 / M 10	–	101 - 110	156	135	20 x 1,8	75	M 6	1.50	10
FRS-L 111 - 119 Universal	539459	X	M 8 / M 10	4"	111 - 119	165	144	20 x 1,8	79	M 6	1.50	10

The two-screw pipe clamp with rapid-locking mechanism and triple connecting nut

2
Pipe clamps



Height adjustable pipe installation

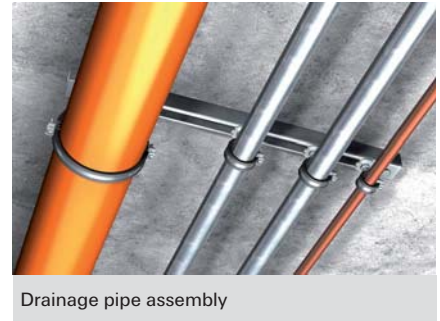

Drainage pipe assembly

APPLICATIONS

- For simple and easy fixing of pipelines with threaded rods or hanger bolts

ADVANTAGES/BENEFITS

- The connecting nut with combination thread M8 / M10 / 1/2" allows for optimised mounting positioning.
- The rapid-locking mechanism allows for fast and time-saving installation.
- The tight fit of the sound insulation insert prevents it from falling out when aligning the pipe.
- The two screws allow for ideal adaptation to suit the outer pipe diameter.

PROPERTIES

- **Material:** steel DD11 (material no. 1.0332) acc. to DIN EN 10111
- **Zinc plating:** electro zinc-plated, min. 5 µm
- **Connecting nut:** resistance welded, M8 / M10 / 1/2"
- **Locking screw:** flat head screw with combination recessed head
- **Material sound insulation insert:** SBR/EPDM; chlorine-free; silicone-free
- **Sound insulation:** for DIN 4109
- **Temperature range:** -50 °C to +110 °C
- **Hardness:** 45 ± 5° Shore A
- **Fire behaviour:** DIN 4102: Class B2

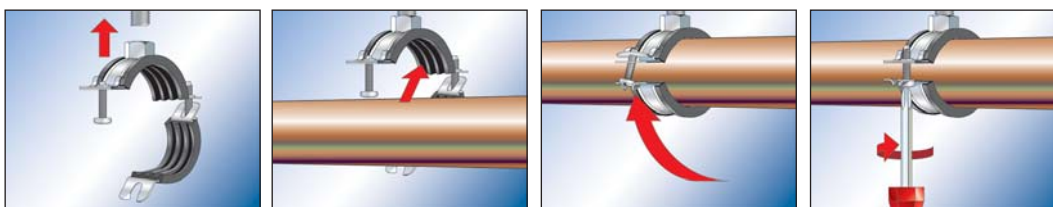

TECHNICAL DATA

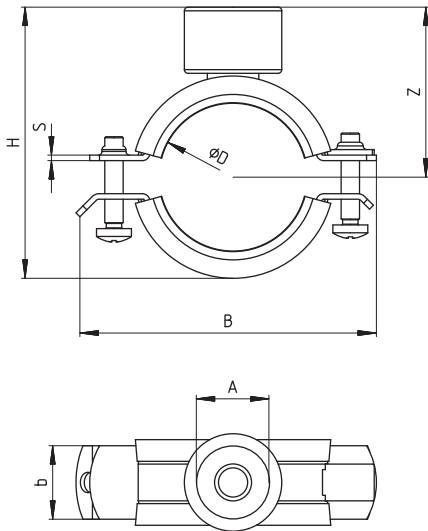

Item	Art.-No.	Thread	Size	Clamping range	Width B	Height H	Width x thickness clamp band	Height Z	Locking screw	Max. recom. static load (centr. tension) N _{recom.} [kN]	Sales unit [pcs]
		A	[inch]	D [mm]	B [mm]	H [mm]	b x s [mm]	Z [mm]			
FRS Triple 15 - 19	500698	M 8 / M 10 / 1/2"	3/8"	15 - 19	61	53	20 x 1,5	36	M 5	1.00	100
FRS Triple 21 - 23	500699	M 8 / M 10 / 1/2"	1/2"	21 - 23	65	57	20 x 1,5	38	M 5	1.00	100
FRS Triple 26 - 28	500700	M 8 / M 10 / 1/2"	3/4"	26 - 28	70	62	20 x 1,5	40	M 5	1.00	100
FRS Triple 32 - 35	500701	M 8 / M 10 / 1/2"	1"	32 - 35	77	69	20 x 1,5	44	M 5	1.00	100
FRS Triple 40 - 43	500702	M 8 / M 10 / 1/2"	1 1/4"	40 - 43	85	77	20 x 1,5	48	M 5	1.00	50
FRS Triple 48 - 56	500703	M 8 / M 10 / 1/2"	1 1/2"	48 - 56	98	90	20 x 1,5	54	M 5	1.00	50
FRS Triple 57 - 62	500704	M 8 / M 10 / 1/2"	2"	57 - 63	104	96	20 x 1,5	57	M 5	1.00	50
FRS Triple 63 - 70	500705	M 8 / M 10 / 1/2"	–	63 - 70	112	104	20 x 1,5	61	M 5	1.00	25
FRS Triple 74 - 80	500706	M 8 / M 10 / 1/2"	2 1/2"	74 - 80	122	114	20 x 1,5	66	M 5	1.00	25
FRS Triple 83 - 91	500707	M 8 / M 10 / 1/2"	3"	83 - 91	133	125	20 x 1,5	72	M 5	1.00	25
FRS Triple 100 - 105	500708	M 8 / M 10 / 1/2"	–	100 - 105	155	139	23 x 2,0	79	M 6	1.50	10
FRS Triple 108 - 114	500709	M 8 / M 10 / 1/2"	4"	108 - 114	164	148	23 x 2,0	83	M 6	1.50	10
FRS Triple 115 - 125	500710	M 8 / M 10 / 1/2"	–	115 - 125	175	159	23 x 2,0	89	M 6	1.50	10
FRS Triple 127 - 135	500711	M 8 / M 10 / 1/2"	–	127 - 135	185	169	23 x 2,0	94	M 6	1.50	10
FRS Triple 135 - 140	500712	M 8 / M 10 / 1/2"	5"	135 - 140	190	174	23 x 2,0	96	M 6	1.50	10
FRS Triple 159 - 169	500713	M 8 / M 10 / 1/2"	6"	159 - 169	219	203	23 x 2,0	111	M 6	1.50	10

The two-screw pipe clamp with combination connecting thread

2
Pipe clamps



Height adjustable pipe installation



Drainage pipe assembly

APPLICATIONS

- Secure fixing for pipes with threaded rods or stud screws (also when there are fire protection requirements)

ADVANTAGES/BENEFITS

- The fire test report guarantees independently tested functional safety.
- The two screws allow an easy adjustment to suit the outer pipe diameter.
- The combination connecting nut with thread M8/M10 enables optimised mounting choices.
- The sound insulation insert offers noise protection and prevents contact corrosion.
- The screw's safety feature ensures trouble-free installation.

CERTIFICATES

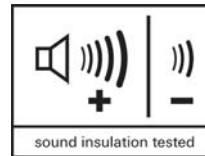

PROPERTIES

- **Material:** steel DC01 (material no. 1.0330) acc. to DIN EN 10 130
- **Zinc plating:** electro zinc-plated, 5 - 9 µm
- **Connecting nut:** resistance welded, M8 / M10, SW 13
- **Locking screw:** flat head screw with combination recessed head
- **Material sound insulation insert:** EPDM; chlorine-free; silicone-free
- **Sound insulation:** for DIN 4 109
- **Temperature range:** -40 °C to +100 °C
- **Hardness:** 55 ± 5° Shore A
- **Fire behaviour:** DIN 4 102: Class B2

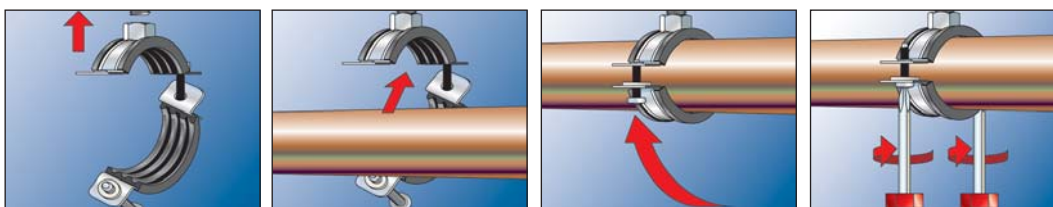

TECHNICAL DATA

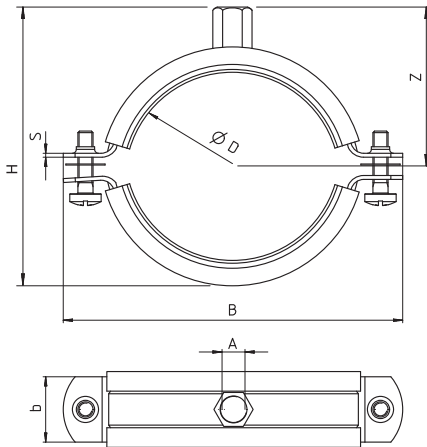

Item	Art.-No.	Fire test report	Thread A	Size [inch]	Clamping range D [mm]	Width B [mm]	Height H [mm]	Width x thickness clamp band b x s [mm]	Height Z [mm]	Locking screw	Max. recom. static load (centr. tension) N _{recom.} [kN]
FRS 12 - 15 M8/M10	510969	X	M 8 / M 10	1/4"	12 - 15	55	39	20 x 1,25	31	M 6	1.00
FRS 15 - 19 M8/M10	042535	X	M 8 / M 10	3/8"	15 - 19	59	43	20 x 1,25	29	M 6	1.00
FRS 20 - 24 M8/M10	042536	X	M 8 / M 10	1/2"	20 - 24	65	48	20 x 1,25	32	M 6	1.00
FRS 25 - 30 M8/M10	042537	X	M 8 / M 10	3/4"	25 - 30	72	54	20 x 1,25	35	M 6	1.00
FRS 32 - 37 M8/M10	042538	X	M 8 / M 10	1"	32 - 37	77	61	20 x 1,25	38	M 6	1.00
FRS 40 - 45 M8/M10	042554	X	M 8 / M 10	1 1/4"	40 - 45	89	69	20 x 1,25	42	M 6	1.00
FRS 48 - 54 M8/M10	510970	X	M 8 / M 10	1 1/2"	48 - 54	99	78	20 x 1,25	46	M 6	1.00
FRS 55 - 61 M8/M10	042555	X	M 8 / M 10	2"	55 - 61	105	85	20 x 1,25	50	M 6	1.00
FRS 63 - 67 M8/M10	091488	X	M 8 / M 10	–	63 - 67	111	91	20 x 1,25	53	M 6	1.00
FRS 72 - 80 M8/M10	091489	X	M 8 / M 10	2 1/2"	72 - 80	125	104	20 x 2,0	60	M 6	1.50
FRS 87 - 92 M8/M10	091505	X	M 8 / M 10	3"	87 - 92	137	116	20 x 2,0	66	M 6	1.50
FRS 108 - 116 M8/M10	091506	X	M 8 / M 10	4"	108 - 116	164	140	25 x 2,0	78	M 6	2.0
FRS 121 - 128 M8/M10	079456	X	M 8 / M 10	–	121 - 128	176	152	25 x 2,5	84	M 6	2.50
FRS 133 - 141 M8/M10	079457	X	M 8 / M 10	5"	133 - 141	187	165	25 x 2,5	90	M 6	2.50
FRS 159 - 165 M8/M10	079458	X	M 8 / M 10	–	159 - 165	211	198	25 x 2,5	102	M 6	2.50
FRS 165 - 168 M8/M10	079459	X	M 8 / M 10	6"	165 - 168	225	192	25 x 2,5	104	M 6	2.50

The two-screw pipe clamp with a sound insulation insert with resistance to high temperatures

2

Pipe clamps



Silicone pipe clamp on sliding element

APPLICATIONS

- Fixing of high-temperature pipelines with threaded rods or stud screws (e.g. steam pipes)

ADVANTAGES/BENEFITS

- The special silicone sound insulation insert allows a use with average temperatures of up to +220 °C.
- The two screws enable an easy adjustment to suit the outer pipe diameter.
- The screw's safety feature ensures trouble-free installation.

PROPERTIES

- **Material:** steel DD11 (material no. 1.0332) acc. to DIN EN 10111
- **Zinc plating:** electro zinc-plated, 5 - 9 µm
- **Connecting nut:** (up to FRSH 59 - 63) resistance welded, M8 and M8 / M10 SW 13, M10 SW 17
- **Locking screw:** flat head screw with combination recessed head
- **Material sound insulation insert:** silicone
- **Sound insulation:** for DIN 4109
- **Temperature range:** -40 °C to +220 °C
- **Hardness:** 60 ± 5° Shore A
- **Fire behaviour:** DIN 4102: Class B2

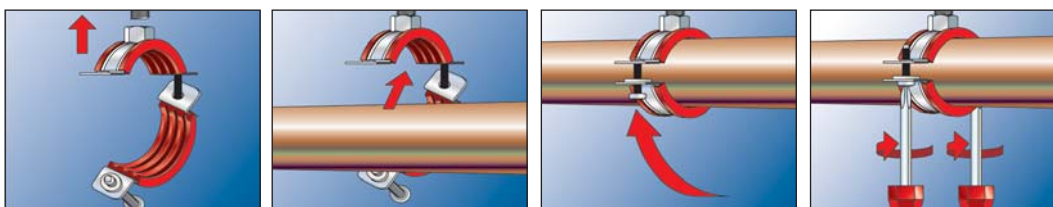

TECHNICAL DATA

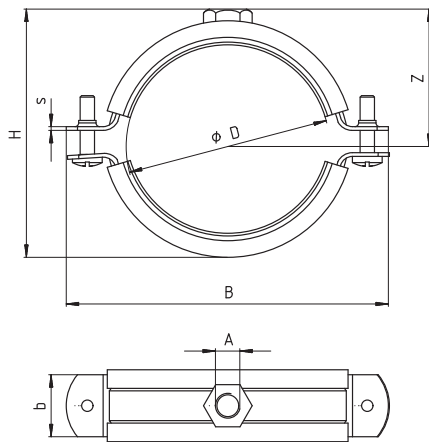

Item	Art.-No.	Thread A	Size [inch]	Clamping range D [mm]	Width B [mm]	Height H [mm]	Width x thickness clamp band b x s [mm]	Height Z [mm]	Locking screw	Max. recom. static load (centr. tension) N _{recom.} [kN]	Sales unit [pcs]
FRSH 15 - 19	063490	M 8	3/8"	15 - 19	62	41	20 x 1,25	24	M 5	1.00	100
FRSH 20 - 24	063492	M 8	1/2"	20 - 24	68	46	20 x 1,25	26	M 5	1.00	100
FRSH 25 - 30	063494	M 8	3/4"	25 - 30	75	52	20 x 1,25	29	M 5	1.00	100
FRSH 32 - 37	063495	M 8	1"	32 - 37	80	59	20 x 1,25	33	M 5	1.00	100
FRSH 40 - 45	063498	M 8	1 1/4"	40 - 45	90	67	20 x 1,25	37	M 5	1.00	50
FRSH 48 - 53	063499	M 8	1 1/2"	48 - 53	97	75	20 x 1,25	41	M 5	1.00	50
FRSH 54 - 59	063500	M 8	–	54 - 59	104	81	20 x 1,25	44	M 5	1.00	50
FRSH 60 - 64	063502	M 8	2"	60 - 64	110	86	20 x 1,25	46	M 5	1.00	50
FRSH 68 - 73	063504	M 10	–	68 - 73	122	95	25 x 1,5	51	M 6	1.30	25
FRSH 72 - 78	063505	M 10	2 1/2"	72 - 78	130	100	25 x 1,5	55	M 6	1.30	25
FRSH 80 - 86	063511	M 10	–	80 - 86	130	108	25 x 1,5	58	M 6	1.30	25
FRSH 89 - 92	063513	M 10	3"	87 - 92	141	114	25 x 1,5	61	M 6	1.30	25
FRSH 95 - 103	063518	M 10	–	95 - 103	156	125	25 x 1,5	67	M 6	1.30	25
FRSH 102 - 116	063520	M 10	4"	102 - 116	172	140	25 x 2,0	74	M 6	2.00	20
FRSH 133 - 141	063537	M 8 / M 10	5"	133 - 141	198	174	25 x 2,5	95	M 8	2.00	10
FRSH 159 - 168	091507	M 8 / M 10	–	159 - 168	226	201	25 x 2,5	109	M 8	2.00	8

The two-screw pipe clamp with rapid-locking mechanism and triple connecting nut

2

Pipe clamps



APPLICATIONS

- For simple and easy fixing of pipelines with threaded rods or hanger bolts

ADVANTAGES/BENEFITS

- The connecting nut with combination thread M8 / M10 / 1/2" allows for optimised mounting positioning.
- The rapid-locking mechanism allows for fast and time-saving installation.
- The two screws allow for ideal adaptation to suit the outer pipe diameter.

PROPERTIES

- **Material:** steel DD11 (material no. 1.0332) acc. to DIN EN 10111
- **Zinc plating:** electro zinc-plated, min. 5 µm
- **Connecting nut:** resistance welded, M8 / M10 / 1/2"
- **Locking screw:** flat head screw with combination recessed head

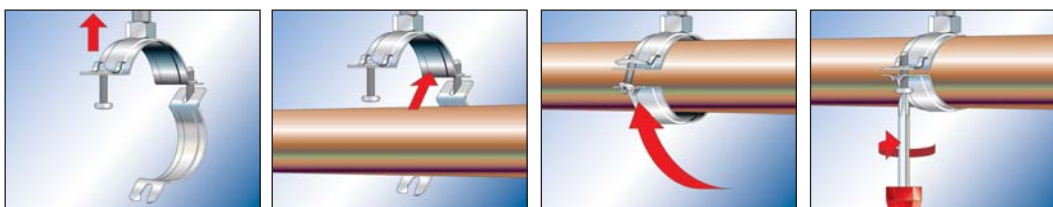

TECHNICAL DATA

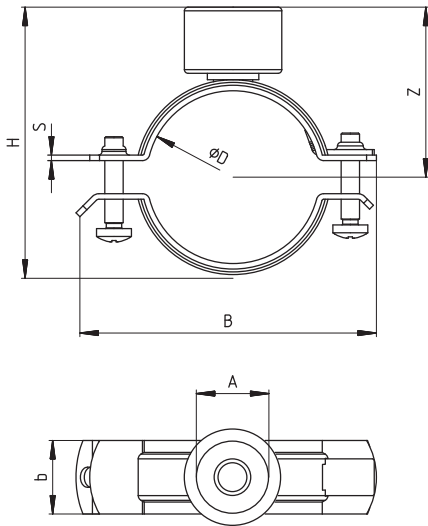

Item	Art.-No.	Thread	Size	Clamping range	Width B	Height H	Width x thickness clamp band	Height Z	Locking screw	Max. recom. static load (centr. tension) N _{recom.} [kN]	Sales unit [pcs]
		A	[inch]	D [mm]	B [mm]	H [mm]	b x s [mm]	Z [mm]			
FRSN Triple 15 - 19	500714	M 8 / M 10 / 1/2"	3/8"	15 - 19	54	44	20 x 1,5	32	M 5	1.00	100
FRSN Triple 21 - 23	500715	M 8 / M 10 / 1/2"	1/2"	21 - 23	58	48	20 x 1,5	34	M 5	1.00	100
FRSN Triple 26 - 28	500716	M 8 / M 10 / 1/2"	3/4"	26 - 28	63	53	20 x 1,5	36	M 5	1.00	100
FRSN Triple 32 - 35	500717	M 8 / M 10 / 1/2"	1"	32 - 35	70	60	20 x 1,5	40	M 5	1.00	100
FRSN Triple 40 - 43	500718	M 8 / M 10 / 1/2"	1 1/4"	40 - 43	78	68	20 x 1,5	44	M 5	1.00	50
FRSN Triple 48 - 56	500719	M 8 / M 10 / 1/2"	1 1/2"	48 - 56	91	81	20 x 1,5	50	M 5	1.00	50
FRSN Triple 57 - 62	500720	M 8 / M 10 / 1/2"	2"	57 - 63	97	87	20 x 1,5	53	M 5	1.00	50
FRSN Triple 63 - 70	500721	M 8 / M 10 / 1/2"	–	63 - 70	105	95	20 x 1,5	57	M 5	1.00	50
FRSN Triple 74 - 80	500722	M 8 / M 10 / 1/2"	2 1/2"	74 - 80	115	105	20 x 1,5	62	M 5	1.00	25
FRSN Triple 83 - 91	500723	M 8 / M 10 / 1/2"	3"	83 - 91	126	116	20 x 1,5	68	M 5	1.00	25
FRSN Triple 100 - 105	500724	M 8 / M 10 / 1/2"	–	100 - 105	148	130	23 x 2,0	74	M 6	1.50	10
FRSN Triple 108 - 114	500725	M 8 / M 10 / 1/2"	4"	108 - 114	157	139	23 x 2,0	78	M 6	1.50	10

The two-screw pipe clamp without sound insulation insert

2

Pipe clamps



APPLICATIONS

- Fixing of metal or plastic pipes without sound insulation requirements with threaded rods or stud screws (e.g. in industrial constructions)

ADVANTAGES/BENEFITS

- The FRSN without the sound insulation insert is ideal for use in industrial applications and plastic pipes.
- The combination connecting nut with thread M8/M10 allows for optimised mounting choices.
- The two screws enable ideal adaptation to suit the outer pipe diameter.
- The screw's safety feature ensures trouble-free installation.

PROPERTIES

- **Material:** steel DD11 (material no. 1.0332) acc. to DIN EN 10111
- **Zinc plating:** electro zinc-plated, 5 - 9 µm
- **Connecting nut:** resistance welded M8 / M10, SW 13, M10 / M12, SW 17
- **Locking screw:** flat head screw with combination recessed head

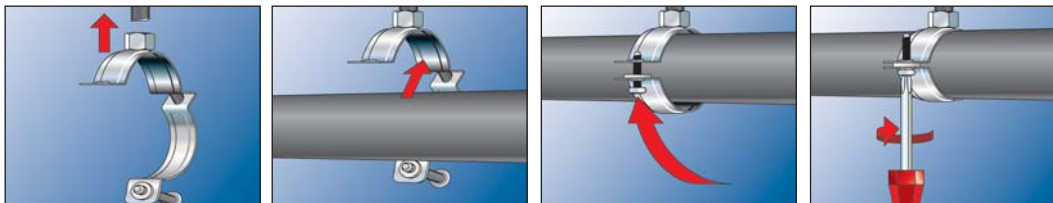

TECHNICAL DATA

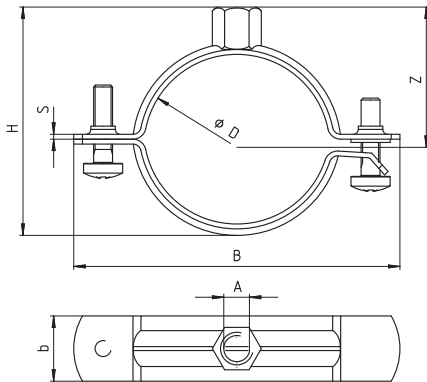

Item	Art.-No.	Thread	Size	Clamping range	Width B	Height H	Width x thickness clamp band	Height Z	Locking screw	Max. recom. static load (centr. tension) N _{recom.} [kN]	Sales unit [pcs]
		A	[inch]	D [mm]	B [mm]	H [mm]	b x s [mm]	Z [mm]			
FRSN 15 - 19 M8/M10	049459	M 8 / M 10	3/8"	15 - 19	56	37	20 x 1,5	27	M 6	1.50	100
FRSN 21 - 23 M8/M10	049789	M 8 / M 10	1/2"	21 - 23	60	41	20 x 1,5	28	M 6	1.50	100
FRSN 25 - 28 M8/M10	049790	M 8 / M 10	3/4"	25 - 28	67	46	20 x 1,5	30	M 6	1.50	100
FRSN 32 - 36 M8/M10	049793	M 8 / M 10	1"	32 - 36	74	54	20 x 1,5	34	M 6	1.50	100
FRSN 38 - 43 M8/M10	049794	M 8 / M 10	1 1/4"	38 - 43	78	61	20 x 1,5	38	M 6	1.50	50
FRSN 44 - 49 M8/M10	049902	M 8 / M 10	1 1/2"	44 - 49	88	67	20 x 1,5	41	M 6	1.50	50
FRSN 50 - 56 M8/M10	049922	M 8 / M 10	–	50 - 56	92	74	20 x 1,5	43	M 6 x 16	1.50	50
FRSN 57 - 61 M8/M10	049944	M 8 / M 10	2"	57 - 61	98	79	20 x 1,5	47	M 6	1.50	50
FRSN 63 - 70 M8/M10	049945	M 8 / M 10	–	63 - 70	105	88	20 x 1,5	54	M 6	1.50	50
FRSN 70 - 77 M8/M10	049947	M 8 / M 10	2 1/2"	70 - 77	112	95	20 x 1,5	55	M 6	1.50	25
FRSN 80 - 83 M8/M10	049948	M 8 / M 10	–	80 - 83	116	101	20 x 1,5	58	M 6	1.50	25
FRSN 83 - 91 M8/M10	049979	M 8 / M 10	3"	83 - 91	128	111	20 x 2,0	63	M 6	2.50	25
FRSN 100 - 106 M8/M10	050006	M 8 / M 10	–	100 - 106	143	126	20 x 2,0	70	M 6	2.50	25
FRSN 108 - 114 M8/M10	050008	M 8 / M 10	4"	108 - 114	156	134	20 x 2,0	75	M 6	2.50	25
FRSN 118 - 122 M8/M10	500744	M 8 / M 10	–	118 - 122	160	142	20 x 2,0	78	M 6	2.50	25
FRSN 123 - 128 M8/M10	050009	M 8 / M 10	–	123 - 128	173	149	25 x 2,5	82	M 6	2.50	25
FRSN 131 - 136 M8/M10	050010	M 8 / M 10	–	131 - 136	176	157	25 x 2,5	86	M 6	2.50	25
FRSN 137 - 146 M8/M10	050023	M 8 / M 10	5"	137 - 146	180	167	25 x 2,5	91	M 6	2.50	25
FRSN 146 - 156 M8/M10	500746	M 8 / M 10	–	146 - 156	195	177	25 x 2,5	96	M 6	2.50	25
FRSN 159 - 165 M10/M12	500747	M 10 / M 12	–	159 - 165	203	191	25 x 2,5	106	M 6	2.50	25
FRSN 166 - 175 M10/M12	500748 1)	M 10 / M 12	–	166 - 175	211	201	25 x 2,5	110	M 8	2.50	20
FRSN 200 - 206 M10/M12	500751 1)	M 10 / M 12	–	200 - 206	248	232	25 x 2,5	126	M 8	2.50	10
FRSN 210 - 219 M10/M12	500752 1)	M 10 / M 12	8"	210 - 219	261	245	25 x 2,5	133	M 8	2.50	10

1) From diameter 166 mm the steel band is punched and delivered with separate locking screw and nut.

The large pipe clamp with sound insulation insert for medium to heavy loads

2
Pipe clamps



Upright pipe on cantilever arm



Pipe elongation with sliding element and suspended pipe

APPLICATIONS

- Fixing of medium to heavy pipes with threaded rods (hanger bolts)

ADVANTAGES/BENEFITS

- The inch threaded connecting nut allows for a pipe fixing with increased bending stress.
- High tested loads ensures the secure functioning of the FRSM.
- The sound insulation insert offers noise protection and prevents contact corrosion.
- The two screws allow an easy adjustment to suit the outer pipe diameter.
- The screw's safety feature ensures trouble-free installation.

PROPERTIES

- **Material:** steel DD11 (material no. 1.0332) acc. to DIN EN 10111
- **Zinc plating:** electro zinc-plated, 5 - 9 µm
- **Connecting nut:** 1/2" resistance welded
- **Locking screw:** flat head screw with combination recessed head
- **Material sound insulation insert:** EPDM; chlorine-free; silicone-free
- **Temperature range:** -50 °C to +110 °C
- **Hardness:** 45 ± 5° Shore A
- **Fire behaviour:** DIN 4102: Class B2

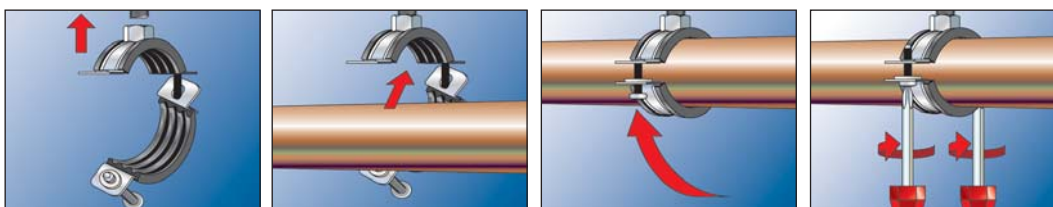

TECHNICAL DATA

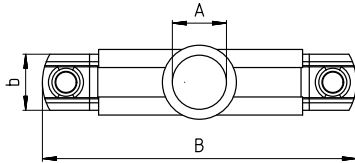
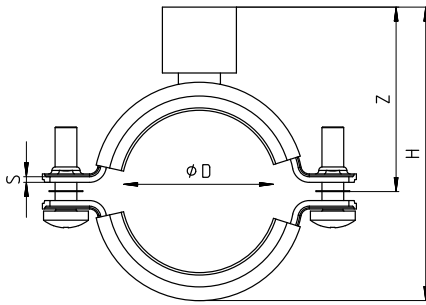

Item	Art.-No.	Thread	Size	Clamping range	Width B	Height H	Width x thickness clamp band	Height Z	Locking screw	Max. recom. static load (centr. tension) $N_{recom.}$ [kN]	Sales unit [pcs]
		A	[inch]	D [mm]	B [mm]	H [mm]	b x s [mm]	Z [mm]			
FRSM 3/8"	535494	1/2"	3/8"	14 - 20	64.3	64	20 x 2,0	44.5	M 6	1.50	25
FRSM 1/2"	535497	1/2"	1/2"	21 - 26	70.6	70	20 x 2,0	47.5	M 6	1.50	25
FRSM 3/4"	535498	1/2"	3/4"	26 - 30	74.8	74	20 x 2,0	49.5	M 6	1.50	25
FRSM 1"	535499	1/2"	1"	31 - 38	81	80	20 x 2,0	52.5	M 6	1.50	25
FRSM 1 1/4"	535500	1/2"	1 1/4"	40 - 47	91.2	90	20 x 2,0	57.5	M 6	1.50	25
FRSM 1 1/2"	535501	1/2"	1 1/2"	48 - 54	100	98	20 x 2,0	61.5	M 6	1.50	25
FRSM 2"	535502	1/2"	2"	60 - 66	111.1	109	20 x 2,0	67	M 6	1.50	25
FRSM 2 1/2"	535503	1/2"	2 1/2"	73 - 80	131.4	123	25 x 2,5	74	M 8	3.15	10
FRSM 3"	535504	1/2"	3"	87 - 94	145.5	137	25 x 2,5	81	M 8	3.15	10
FRSM 110 mm	535505	1/2"	—	105 - 112	165.6	157	25 x 2,5	91	M 8	3.15	10
FRSM 4"	535506	1/2"	4"	112 - 118	171.7	163	25 x 2,5	94	M 8	3.15	10
FRSM 133 mm	535507	1/2"	—	132 - 137	190.8	182	25 x 2,5	103.5	M 8	3.15	10
FRSM 5"	535508	1/2"	5"	137 - 142	195.8	187	25 x 2,5	106	M 8	3.15	10
FRSM 160 mm	535509	1/2"	—	159 - 164	217.9	209	25 x 2,5	117	M 8	3.15	8
FRSM 6"	535511	1/2"	6"	164 - 169	222.9	214	25 x 2,5	119.5	M 8	3.15	8

The large pipe clamp with sound insulation insert for medium to heavy loads

2

Pipe clamps



Heavy pipe on cantilever



Heavy drainage pipe under angle bracket

APPLICATIONS

- Fixing of medium to heavy pipes with threaded rods (hanger bolts)

ADVANTAGES/BENEFITS

- High tested loads guarantee safe functioning of the FRSM.
- The combination connecting nut with thread M10/M12, M12/M16 or M16 allows for optimised mounting choices.
- From Ø 124 mm it is possible to install with 2 threaded rods, e.g. for the fixing of cast iron roof drainage pipes.
- The two screws allow for easy adjustment to suit the outer pipe diameter.
- The screw's safety features ensures trouble-free installation.

PROPERTIES

- **Material:** steel DD11 (material no. 1.0332) acc. to DIN EN 10111
- **Zinc plating:** electro zinc-plated, 5 - 9 µm
- **Connecting nut:** M10 / M12 = SW 17, M12 / M16 = SW 22, M16 = SW 24
- **Locking screw:** flat head screw with combination recessed head to 4", from 4" hexagon screw with nut
- **Material sound insulation insert:** EPDM; chlorine-free; silicone-free
- **Temperature range:** -50 °C to +110 °C
- **Hardness:** 45 ± 5° Shore A
- **Fire behaviour:** DIN 4102: Class B2

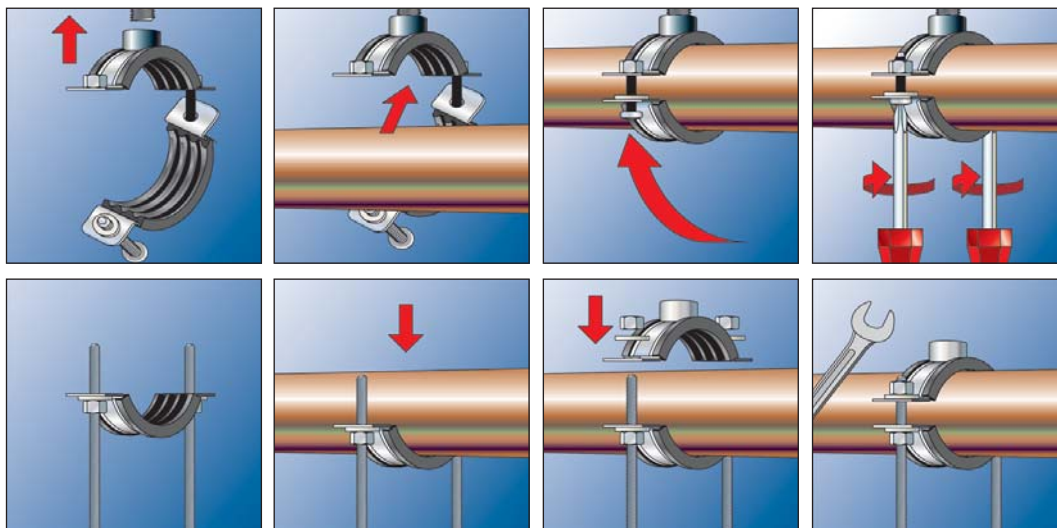

TECHNICAL DATA

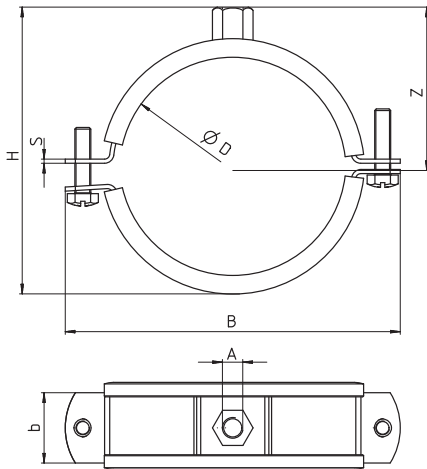

Item	Art.-No.	Thread	Size	Clamping range	Width B	Height H	Width x thickness clamp band	Height Z	Locking screw	Max. recom. static load (centr. tension) N _{recom.} [kN]	Sales unit [pcs]
		A	[inch]	D [mm]	B [mm]	H [mm]	b x s [mm]	Z [mm]			
FRSM 1/2" M10/M12	504589	M 10 / M 12	1/2"	19 - 23	76	57	25 x 2,5	39	M 6	2.50	50
FRSM 3/4" M10/M12	504590	M 10 / M 12	3/4"	24 - 29	80	63	25 x 2,5	42	M 6	2.50	50
FRSM 1" M10/M12	504591	M 10 / M 12	1"	33 - 36	89	70	25 x 2,5	45	M 6	2.50	50
FRSM 1 1/4" M10/M12	504592	M 10 / M 12	1 1/4"	40 - 45	98	79	25 x 2,5	50	M 6	2.50	20
FRSM 1 1/2" M10/M12	093700	M 10 / M 12	1 1/2"	47 - 52	105	86	25 x 2,5	53	M 6	2.50	20
FRSM 53 - 58 M10/M12	093701	M 10 / M 12	—	53 - 58	111	91	25 x 2,5	55	M 6	2.50	20
FRSM 2" M10/M12	093702	M 10 / M 12	2"	60 - 65	118	99	25 x 2,5	60	M 6	2.50	20
FRSM 2 1/2" M10/M12	093703	M 10 / M 12	2 1/2"	73 - 78	136	113	30 x 3,0	67	M 8	3.00	20
FRSM 79 - 85 M10/M12	504593	M 10 / M 12	—	79 - 85	144	120	30 x 3,0	70	M 8	3.00	20
FRSM 3" M10/M12	093704	M 10 / M 12	3"	88 - 93	152	129	30 x 3,0	75	M 8	3.00	20
FRSM 102 M10/M12	093705	M 10 / M 12	—	100 - 106	166	142	30 x 3,0	81	M 8	3.00	20
FRSM 4" M10/M12	093707	M 10 / M 12	4"	108 - 116	175	152	30 x 3,0	86	M 8	3.00	20
FRSM 124 - 129 M10/M12	093709 1)	M 10 / M 12	—	124 - 129	194	165	30 x 3,0	92	M 8	3.00	20
FRSM 133 M10/M12	093710 1)	M 10 / M 12	—	131 - 137	202	173	30 x 3,0	97	M 8	3.00	20
FRSM 5" M10/M12	093711 1)	M 10 / M 12	5"	138 - 145	210	180	30 x 3,0	100	M 8	3.00	20
FRSM 160 M10/M12	093712 1)	M 10 / M 12	—	156 - 162	227	198	30 x 3,0	109	M 8	3.00	20
FRSM 6" M10/M12	093713 1)	M 10 / M 12	6"	165 - 171	255	207	30 x 3,0	114	M 8	3.00	20
FRSM 7" M10/M12	093714 1)	M 10 / M 12	7"	188 - 194	278	230	30 x 3,0	125	M 8	3.00	10
FRSM 200 M10/M12	093715 1)	M 10 / M 12	—	196 - 203	287	239	30 x 3,0	130	M 8	3.00	10
FRSM 212 M12/M16	505453 1)	M 12 / M 16	—	205 - 214	289	264	40 x 4,0	147	M 12	5.00	10
FRSM 8" M12/M16	505454 1)	M 12 / M 16	8"	219 - 225	300	272	40 x 4,0	152	M 12	5.00	10
FRSM 250 M12/M16	505455 1)	M 12 / M 16	—	244 - 250	325	300	40 x 4,0	165	M 12	5.00	10
FRSM 10" M12/M16	505456 1)	M 12 / M 16	10"	267 - 273	348	323	40 x 4,0	177	M 12	5.00	10
FRSM 300 M12/M16	505457 1)	M 12 / M 16	—	297 - 304	379	354	40 x 4,0	192	M 12	5.00	10
FRSM 12" M12/M16	505458 1)	M 12 / M 16	12"	320 - 328	403	378	40 x 4,0	204	M 12	5.00	10
FRSM 348 - 356 M16	504594 1)	M 16	—	348 - 356	480	403	50 x 5,0	213	M 16	8.00	1
FRSM 364 - 372 M16	504595 1)	M 16	—	364 - 372	496	419	50 x 5,0	221	M 16	8.00	1
FRSM 400 - 409 M16	504596 1)	M 16	—	400 - 409	533	456	50 x 5,0	240	M 16	8.00	1
FRSM 454 - 462 M16	504597 1)	M 16	—	454 - 462	586	509	50 x 5,0	266	M 16	8.00	1
FRSM 500 - 508 M16	504598 1)	M 16	—	500 - 508	632	555	50 x 5,0	290	M 16	8.00	1

1) From diameter 124 mm the steel band is punched and delivered with separate locking screw and nut.

The two-screw refrigeration pipe clamp with integrated insulation

2

Pipe clamps



Refrigerant pipe clamps

APPLICATIONS

- Installation of pipes in refrigeration and air-conditioning applications

ADVANTAGES/BENEFITS

- The self-adhesive material ensures easy installation of the refrigeration pipe clamp.
- Age-resistant material ensures a long life of the FRS-K.
- The double-threaded connection nut allows for flexibility during the installation.
- The screw's safety feature ensures trouble-free installation.
- The integrated load distribution sheet guarantees the load transmission and allows higher loads.

PROPERTIES

- **Material:** polyurethan-foam, silicone-free, CFC-free
- **Diffusion resistance:** 7000 μ
- **Density:** 80 kg/m³
- **Compressive strength:** 0,67-0,75 mPa
- **Heat conductivity (at 0 °C):** 0,024-0,026 W/mK
- **Locking screw:** flat head screw with combination recessed head
- **Temperature range:** -45 °C to +105 °C
- **Fire behaviour:** DIN 4102: Class B2

TECHNICAL DATA

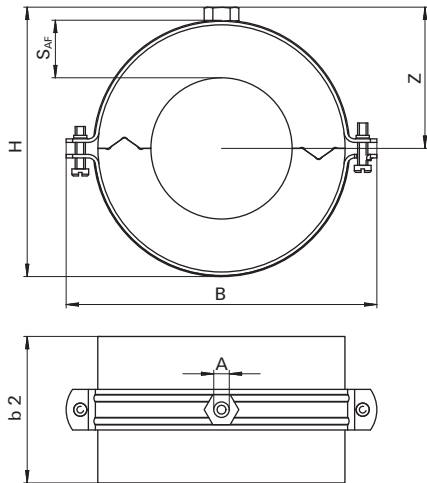

Item	Art.-No.	Size	Thread	Insulation thickness	Width B	Height H	Height Z	Locking screw	Length of insulation material	Max. recom. static load (centr. tension)	Sales unit
		[inch]	A	S _{AF} [mm]	B [mm]	H [mm]	Z [mm]		b2 [mm]	N _{recom.} [kN]	[pcs]
FRS K 12/13	506486	—	M 8 / M 10	13	77	59	33	M 6	50	0.10	1
FRS K 15/13	506487	1/4"	M 8 / M 10	13	85	64	37	M 6	50	0.11	1
FRS K 17-18/13	506488	3/8"	M 8 / M 10	13	86	64	37	M 6	50	0.12	1
FRS K 21-22/13	506489	1/2"	M 8 / M 10	13	90.5	69	40	M 6	50	0.13	1
FRS K 27-28/13	506490	3/4"	M 8 / M 10	13	98.5	78	46	M 6	50	0.15	1
FRS K 34-35/13	506491	1"	M 8 / M 10	13	105	83	49	M 6	50	0.17	1
FRS K 42/13	506492	1 1/4"	M 8 / M 10	13	115	96	53	M 6	50	0.36	1
FRS K 48-49/13	506493	1 1/2"	M 8 / M 10	13	118	102	56	M 6	50	0.39	1
FRS K 54/13	507699	—	M 8 / M 10	13	125	107	59	M 8	50	0.42	1
FRS K 60/13	506494	2"	M 8 / M 10	13	132	115	63	M 6	50	0.45	1
FRS K 12/19	506495	—	M 8 / M 10	19	90	71	41	M 6	50	0.14	1
FRS K 15/19	506496	1/4"	M 8 / M 10	19	90.5	74	42	M 6	50	0.15	1
FRS K 17-18/19	506497	3/8"	M 8 / M 10	19	99	77	44	M 6	50	0.15	1
FRS K 21-22/19	506498	1/2"	M 8 / M 10	19	99	77	44	M 6	50	0.16	1
FRS K 27-28/19	506499	3/4"	M 8 / M 10	19	106	90	50	M 6	50	0.18	1
FRS K 34-35/19	506500	1"	M 8 / M 10	19	115	97	53	M 6	50	0.20	1
FRS K 42/19	506501	1 1/4"	M 8 / M 10	19	125	109	59	M 6	50	0.42	1
FRS K 48-49/19	506502	1 1/2"	M 8 / M 10	19	132	116	62.5	M 6	50	0.45	1
FRS K 54/19	507700	—	M 8 / M 10	19	143	123	65.5	M 8	50	0.48	1
FRS K 60/19	506503	2"	M 8 / M 10	19	147	129	69	M 6	50	0.51	1
FRS K 64/19	506504	—	M 8 / M 10	19	149	134	71	M 6	50	0.53	1
FRS K 70/19	506505	—	M 8 / M 10	19	161	142	75	M 6	50	0.56	1
FRS K 76/19	506506	2 1/2"	M 8 / M 10	19	162.5	147	77	M 6	50	0.60	1
FRS K 89/19	506508	3"	M 8 / M 10	19	188	165	86.5	M 8	50	0.66	1
FRS K 102/19	506509	—	M 8 / M 10	19	199	180	94.5	M 8	100	1.69	1
FRS K 108/19	506510	—	M 8 / M 10	19	204	185	97	M 8	100	1.77	1
FRS K 114/19	506511	4"	M 12 / M 16	19	241	201	112	M 8	100	1.84	1
FRS K 133/19	507786	—	M 12 / M 16	19	270	221	122	M 8	100	2.07	1
FRS K 139/19	507787	5"	M 12 / M 16	19	270	227	125	M 8	100	2.14	1
FRS K 168/19	507788	6"	M 12 / M 16	19	281	256	139	M 8	100	2.49	1
FRS K 219/19	539477	—	M 12 / M 16	19	346	290	156.6	M 12	100	2,94	1

The two-screw refrigeration pipe clamp made from closed PUR foam

2

Pipe clamps



Refrigerant pipe clamps



Refrigerant pipe clamp on sliding element

APPLICATIONS

- Installation of pipes in refrigeration and air-conditioning applications with high loads

ADVANTAGES/BENEFITS

- The refrigeration pipe clamp KFT made from closed PUR foam can be used with all standard insulation materials.
- The glued rubber overlay makes the installation easier.
- The triple-threaded connection nut M8 / M10 / 1/2" allows for flexibility during the installation.
- Age-resistant material ensures the long-term functionality of the KFT.
- The two screws allow an easy adjustment to suit the outer pipe diameter.

PROPERTIES

- **Material:** closed-cell polyurethane foam, silicone-free
- **Diffusion resistance:** 1000 μ
- **Density:** 250 kg/m³
- **Compression strength:** 3,96 mPa at 23 °C
- **Heat conductivity (at 0 °C):** 0,049 W/(m*K)
- **Temperature range:** -160 °C to +130 °C
- **Fire behaviour:** DIN 4102: Class B2

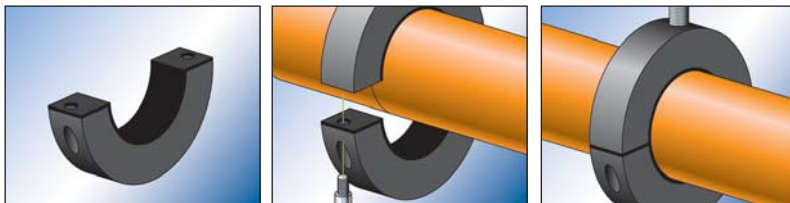

TECHNICAL DATA

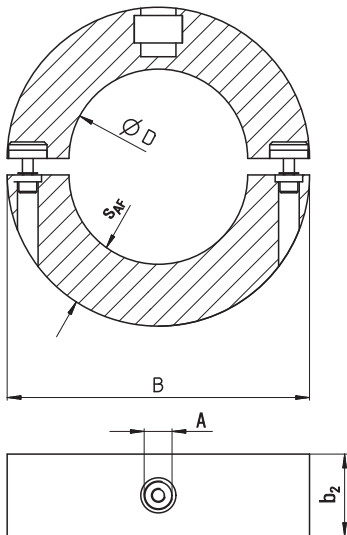

Item	Art.-No.	Thread	Internal diameter	Width B	Locking screw	Max. recom. static load (centr. tension) N _{recom.} [kN]	Insulation thickness S _{AF} [mm]	Length of insulation material b ₂ [mm]	Sales unit [pcs]
		A	D [mm]	B [mm]					
KFT 9,5	505576	1) M 8 / M 10 / 1/2"	9,5	88	M 6	0.15	30	40	1
KFT 12,7	505577	M 8 / M 10 / 1/2"	12,7	88	M 6	0.20	30	40	1
KFT 15,8	505578	M 8 / M 10 / 1/2"	15,8	88	M 6	0.21	30	40	1
KFT 17,2	505579	1) M 8 / M 10 / 1/2"	17,2	88	M 6	0.21	30	40	1
KFT 18,0	505580	M 8 / M 10 / 1/2"	18,0	88	M 6	0.21	30	40	1
KFT 19,5	505581	1) M 8 / M 10 / 1/2"	19,5	88	M 6	0.21	30	40	1
KFT 21,3	505582	M 8 / M 10 / 1/2"	21,3	88	M 6	0.26	30	40	1
KFT 22,0	505583	M 8 / M 10 / 1/2"	22,0	88	M 6	0.26	30	40	1
KFT 26,9	505584	M 8 / M 10 / 1/2"	26,9	88	M 6	0.32	30	40	1
KFT 28,0	505585	M 8 / M 10 / 1/2"	28,0	88	M 6	0.32	30	40	1
KFT 33,7	505587	M 8 / M 10 / 1/2"	33,7	96	M 6	0.40	30	40	1
KFT 35,0	505588	M 8 / M 10 / 1/2"	35,0	96	M 6	0.42	30	40	1
KFT 40,0	505589	1) M 8 / M 10 / 1/2"	40,0	100	M 6	0.42	30	40	1
KFT 41,2	505591	M 8 / M 10 / 1/2"	41,2	100	M 6	0.51	30	40	1
KFT 42,4	505592	M 8 / M 10 / 1/2"	42,4	103	M 6	0.51	30	40	1
KFT 44,5	505593	1) M 8 / M 10 / 1/2"	44,5	103	M 6	0.51	30	40	1
KFT 48,3	505594	M 8 / M 10 / 1/2"	48,3	102	M 6	0.58	30	40	1
KFT 50,0	505595	1) M 8 / M 10 / 1/2"	50,0	112	M 6	0.60	30	40	1
KFT 54,0	505596	M 8 / M 10 / 1/2"	54,0	116	M 6	0.62	30	40	1
KFT 57,0	505597	M 8 / M 10 / 1/2"	57,0	116	M 6	0.65	30	40	1
KFT 60,3	505598	M 8 / M 10 / 1/2"	60,3	123	M 6	0.72	30	50	1
KFT 64,0	505599	M 8 / M 10 / 1/2"	64,0	123	M 6	0.77	30	50	1
KFT 70,0	505901	M 8 / M 10 / 1/2"	70,0	132	M 8	1.26	30	50	1
KFT 74,0	505902	1) M 8 / M 10 / 1/2"	74,0	132	M 8	1.26	30	50	1
KFT 76,1	505903	M 8 / M 10 / 1/2"	76,1	132	M 8	1.37	30	50	1
KFT 80,0	505904	1) M 8 / M 10 / 1/2"	80,0	132	M 8	1.37	30	50	1
KFT 84,0	505905	1) M 8 / M 10 / 1/2"	84,0	150	M 8	1.60	30	50	1
KFT 88,9	505906	M 8 / M 10 / 1/2"	88,0	150	M 8	1.60	30	50	1
KFT 92,1	505907	1) M 8 / M 10 / 1/2"	92,1	150	M 8	1.60	30	50	1
KFT 101,0	505908	1) M 8 / M 10 / 1/2"	101,0	188	M 8	2.59	40	60	1
KFT 104,0	505909	1) M 8 / M 10 / 1/2"	104,0	188	M 8	2.59	40	60	1
KFT 108,0	505910	M 8 / M 10 / 1/2"	108,0	188	M 8	2.59	40	60	1
KFT 114,3	505911	M 8 / M 10 / 1/2"	114,3	195	M 8	2.74	40	60	1
KFT 129,0	505914	1) M 8 / M 10 / 1/2"	129,0	220	M 8	3.19	40	60	1
KFT 133,0	505915	M 8 / M 10 / 1/2"	133,0	220	M 8	3.19	40	60	1
KFT 139,7	505916	M 8 / M 10 / 1/2"	139,7	220	M 8	3.35	40	60	1

TECHNICAL DATA

2

Pipe clamps

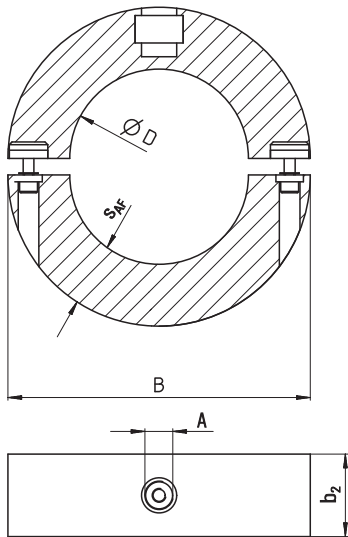

Item	Art.-No.	Thread	Internal diameter	Width B	Locking screw	Max. recom. static load (centr. tension)	Insulation thickness	Length of insulation material	Sales unit
		A	D [mm]	B [mm]		$N_{recom.}$ [kN]	S_{AF} [mm]	b_2 [mm]	
KFT 154,0	505917 ¹⁾	M 12 / 1/2"	154,0	239	M 10	3.83	40	60	1
KFT 159,0	505918	M 12 / 1/2"	159,0	239	M 10	3.83	40	60	1
KFT 168,3	505919	M 12 / 1/2"	168,3	250	M 10	4.04	40	60	1
KFT 193,7	505920 ¹⁾	M 16 / 1/2"	193,7	340	M 10	5.26	60	100	1
KFT 204,0	505921 ¹⁾	M 16 / 1/2"	204,0	340	M 10	5.20	60	100	1
KFT 219,1	505922	M 16 / 1/2"	219,1	340	M 10	5.26	60	100	1

¹⁾ delivery on request

The U-bolt with metric thread



ADVANTAGES/BENEFITS

- The U-bolt's two screws allow an ideal adaptation to suit the outer pipe diameter.

PROPERTIES

- **Material:** steel with min. tensile strength of 360 N/mm²
- **Zinc plating:** electro zinc-plated

APPLICATIONS

- Installation of standing or hanging pipes
- Pipe routing on profiles and consoles

TECHNICAL DATA

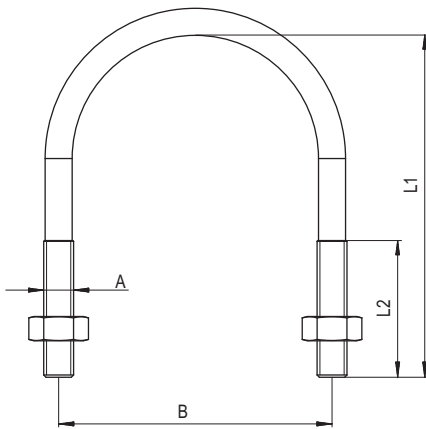

Item	Art.-No.	Thread	Length	Length	Size	Width B	Sales unit		
		A	L1 [mm]	L2 [mm]	[inch]	B [mm]	[pcs]		
ETR 8 - 13	024415	M 6	30	20	1/4"	20	10		
ETR 12 - 17	024416	M 6	35	20	3/8"	24	10		
ETR 15 - 21	024417	M 6	40	25	1/2"	28	10		
ETR 20 - 27	024418	M 8	50	32	3/4"	36	10		
ETR 26 - 34	024419	M 8	55	32	1"	43	10		
ETR 33 - 42	024420	M 8	68	38	1 1/4"	51	10		
ETR 40 - 49	024421	M 8	70	38	1 1/2"	58	10		
ETR 50 - 60	024422	M 8	80	40	2"	69	10		
ETR 60 - 70	024423	M 10	100	43	–	82	10		
ETR 66 - 76	024424	M 10	110	50	2 1/2"	88	10		
ETR 70 - 82	024425	M 10	115	50	–	94	10		
ETR 80 - 90	024426	M 10	115	50	3"	102	10		
ETR 90 - 102	024427	M 12	145	55	3 1/2"	116	5		
ETR 100 - 108	024428	M 12	150	50	–	122	5		
ETR 102 - 114	024429	M 12	156	60	4"	128	5		
ETR 121 - 127	024430	M 12	170	60	–	141	5		
ETR 126 - 133	024431	M 12	180	70	–	147	5		
ETR 131 - 140	024432	M 14	185	70	5"	156	5		
ETR 143 - 153	024433 ¹⁾	M 14	193	70	–	169	5		
ETR 150 - 159	024434	M 14	200	70	–	175	5		
ETR 168	024435	M 14	210	70	6"	184	5		
ETR 193,7	024436	M 14	232	70	–	209	5		
ETR 219	024437	M 14	270	70	8"	236	5		

1) Delivery time on request.

The universal sprinkler loop

2
Pipe clamps

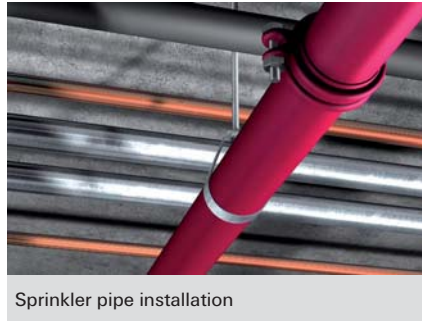

APPLICATIONS

- Installation of sprinkler pipes

ADVANTAGES/BENEFITS

- The FM-approval guarantees independently tested safety for the use in sprinkler systems.
- The sprinkler loop with clearance hole enables an easy fixing with threaded rod and nut.

CERTIFICATES



PROPERTIES

- **Material:** steel DX51D+Z 275 MA acc. to DIN EN 10142
- **Zinc plating:** sendzimir-galvanised, min. 15 µm

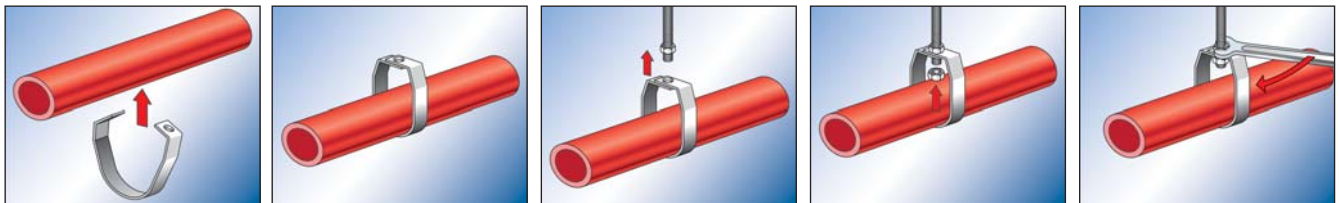

TECHNICAL DATA

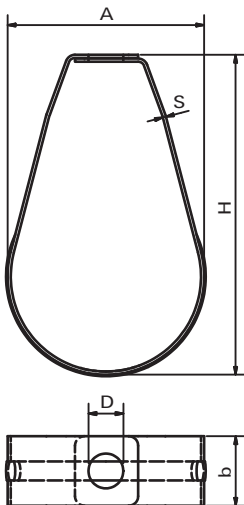

2

Pipe clamps

		FM approved	Eye Ø	Width A	Height H	Width x thick- ness clamp band	Max. recom. static load (centr. tension)	Sales unit		
Item	Art.-No.		D	[mm]	H	b x s	$N_{recom.}$	[pcs]		
FRSP 1/2"	524035	–	11	46	62	22 x 1,0	1.50	100		
FRSP 3/4"	524036	X	11	46	62	22 x 1,0	1.50	100		
FRSP 1"	524037	X	11	46	70	22 x 1,0	1.50	100		
FRSP 1 1/4"	524038	X	11	50	82	22 x 1,0	1.50	100		
FRSP 1 1/2"	524039	X	11	50	93	22 x 1,0	1.50	100		
FRSP 2"	524040	X	11	62.2	102	22 x 1,0	1.50	100		
FRSP 2 1/2"	524041	X	11	82	120	22 x 1,5	4.50	50		
FRSP 3"	524042	X	11	94.9	139	22 x 1,5	4.50	50		
FRSP 4"	524043	X	11	117.2	180	22 x 1,5	4.50	25		
FRSP 5"	524044	X	13	143.6	218	32 x 2,0	5.20	20		
FRSP 6"	524045	X	13	172.2	237	32 x 2,0	5.20	15		
FRSP 8"	524046	X	16,5	224	318	32 x 2,5	5.20	10		

The premium sprinkler loop with separable band and height adjustment, VdS approved

2
Pipe clamps

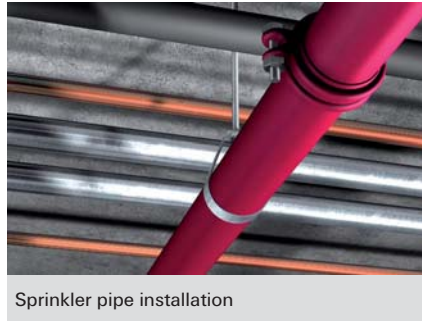

APPLICATIONS

- Installation of sprinkler pipes according VdS

ADVANTAGES/BENEFITS

- The VdS approval guarantees independently tested safety for the use in sprinkler systems.
- The adjustment nut enables a simple, post-installation height adjustment of the pipes.

CERTIFICATES



G 410037 / G 410034

PROPERTIES

- Material pipe loop:** steel DX51D acc. to DIN EN 10346, material no. 1.0226 (Z140 N-A-C)
- Material adjustment nut:** steel 11 SMnPb 30 acc. to DIN EN 10087, material no. 1.0718
- Zinc plating:** sendzimir-galvanised, min. 8 µm

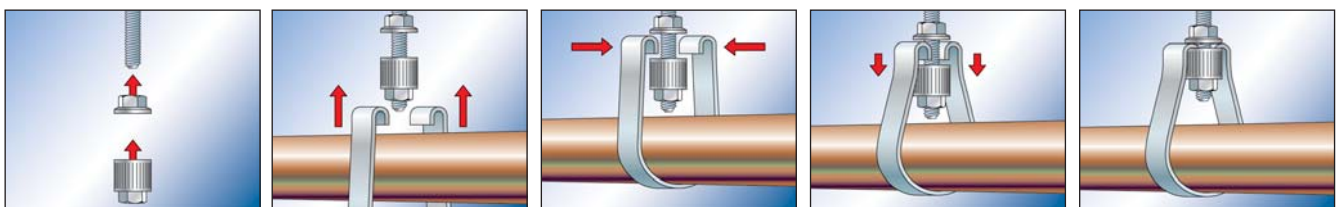

TECHNICAL DATA

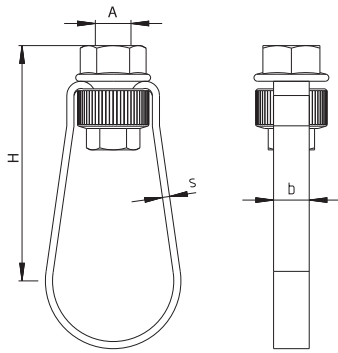

Item	Art.-No.	VdS approved	Size [inch]	Thread A	Height H [mm]	Width x thick- ness clamp band b x s [mm]	Max. recom. static load (centr. tension) $N_{recom.}$ [kN]	Sales unit [pcs]		
FRSL 34 M8	538082	X	1"	M 8	67	10 x 1,8	2.0	50		
FRSL 43 M8	538083	X	1 1/4"	M 8	67	10 x 1,8	2.0	50		
FRSL 49 M8	538084	X	1 1/2"	M 8	72	10 x 1,8	2.0	50		
FRSL 60 M8	538085	X	2"	M 8	81	10 x 1,8	2.0	50		
FRSL 34	513302	X	1"	M 10	67	10 x 1,8	2.0	50		
FRSL 43	513303	X	1 1/4"	M 10	67	10 x 1,8	2.0	50		
FRSL 49	513304	X	1 1/2"	M 10	72	10 x 1,8	2.0	50		
FRSL 60	513307	X	2"	M 10	81	10 x 1,8	2.0	50		
FRSL 76	513308	X	2 1/2"	M 10	98	10 x 2,5	3.5	25		
FRSL 90	513309	X	3"	M 10	113	10 x 2,5	3.5	25		
FRSL 115	513310	X	4"	M 10	143	10 x 2,5	3.5	25		
FRSL 140	513311	X	5"	M 12	157	13 x 2,5	5.0	25		
FRSL 170	513312	X	6"	M 12	187	13 x 2,5	5.0	25		

The easy handling pipe and cable clamp for direct attachment of lines to FUS mounting rails

2

Pipe clamps



Supply lines fixed to FUS channel

APPLICATIONS

- Fast installation of metal and plastic pipes, flexible plastic pipes or cables without sound insulation requirements directly to FUS installation channels
- Fits to FUS channels FUS 21, FUS 41, FUS 62, FUS 21D, FUS 41D, FUS 62D

ADVANTAGES/BENEFITS

- The FUBD without soundproofing is ideal for use in industrial applications, for example, for fixing lightweight flexible supply lines in the immediate area of production machines.
- Locking screw with hexagonal and slot drive.
- Quick adaptation to the desired outside pipe diameter by fastening the pressure pan.
- No loss of parts due to preassembled parts.
- Time- and cost-saving installation without the need of accessories like threaded rods or sliding nuts.

PROPERTIES

- **Material U-Strap:** steel S235JRC (Werkstoff-Nr.: 1.0122) acc. to EN 10025
- **Zinc plating U-Strap:** hot-dip galvanised min. 35 µm acc. to DIN EN ISO 1461
- **Material Pressure pan:** steel DX51D acc. to DIN EN 10346
- **Zinc plating Pressure pan:** electro zinc plated, min. 5 µm acc. to DIN EN ISO 4042
- **Material Locking screw:** steel 4.6 acc. to EN 20898-1
- **Locking screw:** with hexagonal SW10 and slot head

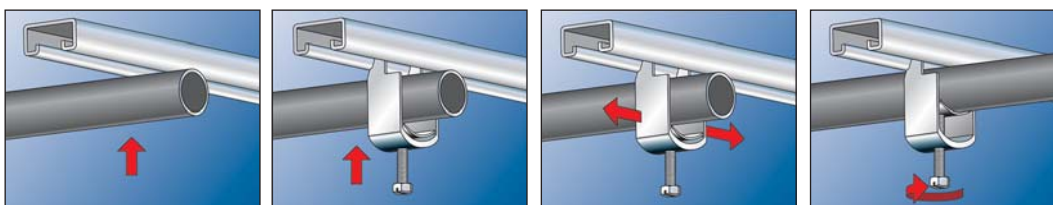

TECHNICAL DATA

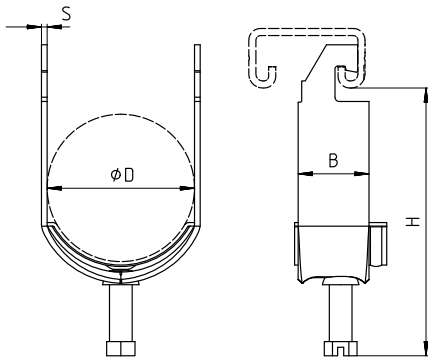

Item	Art.-No.	Clamping range	Height H	Width x thickness clamp band b x s	Locking screw	Sales unit
		D [mm]	H [mm]	[mm]		[pcs]
FUBD 40	539564	36 - 40	71	25 x 1,75	M 6 x 24	100
FUBD 52	539566	48 - 52	90	25 x 2,0	M 8 x 30	50
FUBD 60	539567	56 - 60	98	30 x 2,25	M 8 x 30	50
FUBD 76	539568	70 - 76	113	30 x 2,75	M 8 x 30	25
FUBD 94	539569	88 - 94	141	30 x 2,75	M8 x 40	20
FUBD 100	539570	94 - 100	147	30 x 2,75	M8 x 40	10

The hose clamp for large hoses, pipe or ducting

2
Pipe clamps



ADVANTAGES/BENEFITS

- The crimped band edges offer protection against damage to the hose.
- The short base of the hosing allows an ideal adjustment and high, radial forces on the hose diameter.
- The screw's combination cross-drive thread enables installation flexibility.

PROPERTIES

- **Material class:** W 2
- **Worm:** CQ 15 (material no. 1.1132) acc. to DIN EN 10263
- **Housing and band:** chromium steel (material no. 1.4016) acc. to DIN EN 10088 or equivalent corrosion-resistant steel

APPLICATIONS

- Sealing of hoses
- Fixing hoses to adapters

TECHNICAL DATA

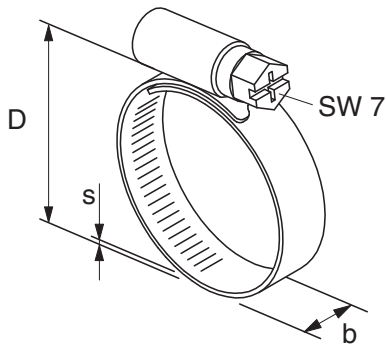



Item	Art.-No.	Clamping range D [mm]	Width x thickness clamp band b x s [mm]	Sales unit [pcs]					
SGS 9 W2 8 - 12	045517	8 - 12	9,0 x 0,6	100					
SGS 9 W2 10 - 16	045518	10 - 16	9,0 x 0,6	100					
SGS 9 W2 12 - 20	045519	12 - 20	9,0 x 0,6	100					
SGS 9 W2 16 - 27	045520	16 - 27	9,0 x 0,6	100					
SGS 9 W2 20 - 32	045521	20 - 32	9,0 x 0,6	100					
SGS 9 W2 25 - 40	045522	25 - 40	9,0 x 0,6	100					
SGS 9 W2 32 - 50	045523	32 - 50	9,0 x 0,6	100					
SGS 9 W2 40 - 60	045524	40 - 60	9,0 x 0,6	25					
SGS 9 W2 50 - 70	045525	50 - 70	9,0 x 0,6	25					
SGS 9 W2 60 - 80	045526	60 - 80	9,0 x 0,6	25					
SGS 9 W2 70 - 90	045527	70 - 90	9,0 x 0,6	25					
SGS 9 W2 80 - 100	045528	80 - 100	9,0 x 0,6	25					
SGS 9 W2 90 - 110	045529	90 - 110	9,0 x 0,6	25					
SGS 9 W2 100 - 120	045530	100 - 120	9,0 x 0,6	25					
SGS 9 W2 110 - 130	045531	110 - 130	9,0 x 0,6	25					
SGS 9 W2 120 - 140	045532	120 - 140	9,0 x 0,6	25					



3

Installation system FLS

	page		page
Channels		Construction elements	
Channel FLS	 88	Channel connector SV 31	 96
Cantilever		Saddle flange SF Clix 31	 104
Cantilever arm ALK	 91	Angle bracket MW Clix 90°	 106
Cover cap AK	 93	Angle bracket MW and MWU	 108
Angle brace WS 31-45°	 94	Beam TKR 31	 111
Connectors			
Sliding channel nut FSM Clix P	 98		
Sliding channel nut FSM Clix M	 100		
T-head bolt FHS Clix	 102		
Channel washer HK 31	 110		

The flexible channel system for light applications

3 Installation system FLS



Air duct fixing with channel

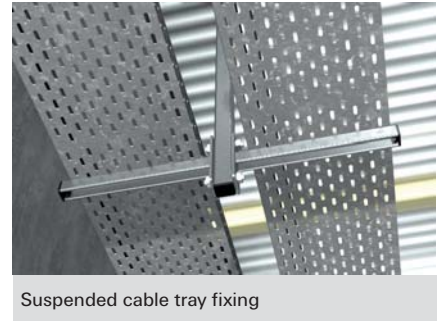

Suspended cable tray fixing

APPLICATIONS

- The U-profile channels enable the creation of secure, horizontal and vertical installations.
- The channel system is suitable for fast and efficient fixings of pipelines and supporting structures.

ADVANTAGES/BENEFITS

- The fire inspection report in line with MLAR/EN 1363-1 of the FLS 37 guarantees independently tested functional safety.
- The channel shape with edge seams gives a perfect fit for the connector elements and leads to a safe and easy installation.
- The serration with stamped teeth in the mounting channel gives the sliding nuts a secure hold to bear high shear loads.
- The scale on the channels simplifies the cutting of the channels and the positioning of the connector elements during installation.
- The alternating long slots in the channel enable the optimised fixing to the substrate with the perfect fixtures.

CERTIFICATES

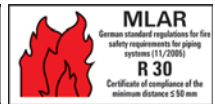

PROPERTIES

- **Material:** steel S-250-GD (material no.: 1.0242) acc. to DIN EN 10346
- **Zinc plating:** sendzimir-galvanised, app. 20 µm



TECHNICAL DATA

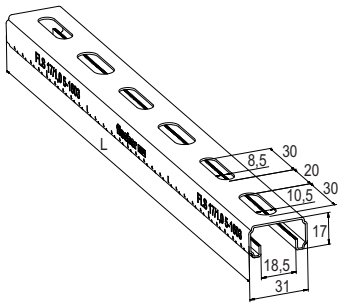

FLS 17/1.0

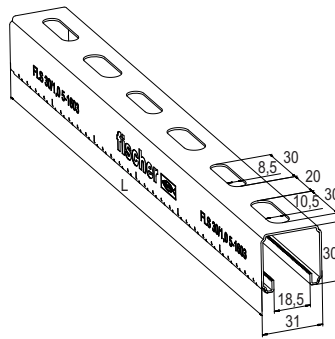

FLS 30/1.0

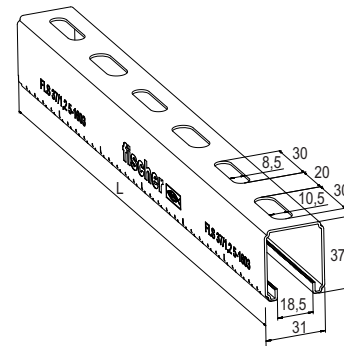

FLS 37/1.2

Item	Art.-No.	Fire test report	Thickness	Length	Sales unit
			[mm]	L [mm]	
FLS 17/1.0 - 2 m	538753	—	1.0	2000	10
FLS 17/1.0 - 3 m	538754	—	1.0	3000	8
FLS 30/1.0 - 2 m	538755	—	1.0	2000	10
FLS 30/1.0 - 3 m	538756	—	1.0	3000	8
FLS 37/1.2 - 2 m	538757	X	1.2	2000	10
FLS 37/1.2 - 3 m	538758	X	1.2	3000	8
FLS 37/1.2 - 6 m	538759	X	1.2	6000	1

LOADS

Item	Art.-No.	Weight [kg/m]	Profile cross section [cm ²]	Moment of inertia I _y [cm ⁴]	Moment of inertia I _z [cm ⁴]	Section modulus W _y [cm ³]	Section modulus W _z [cm ³]	Max. recommended static load for 1m length
								F _{rec} [kN]
FLS 17/1.0 - 2 m	538753	0.58	0.72	0.25	0.91	0.26	0.59	0.13
FLS 17/1.0 - 3 m	538754	0.58	0.72	0.25	0.91	0.26	0.59	0.13
FLS 30/1.0 - 2 m	538755	0.78	0.98	1.02	1.46	0.64	0.94	0.48
FLS 30/1.0 - 3 m	538756	0.78	0.98	1.02	1.46	0.64	0.94	0.48
FLS 37/1.2 - 2 m	538757	1.06	1.33	2.03	2.01	1.04	1.29	0.78
FLS 37/1.2 - 3 m	538758	1.06	1.33	2.03	2.01	1.04	1.29	0.78
FLS 37/1.2 - 6 m	538759	1.06	1.33	2.03	2.01	1.04	1.29	0.78

SEE ALSO



ULTRACUT FBS II / FBS
see page 305

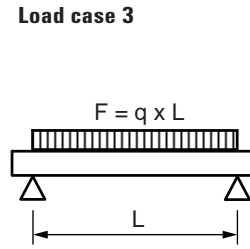
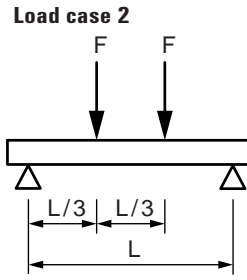
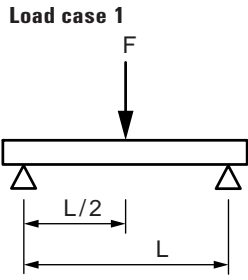

FLS 17/1.0

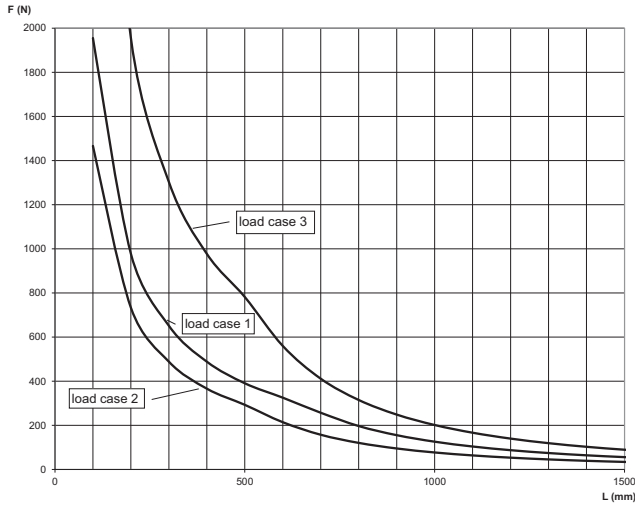

FLS 30/1.0

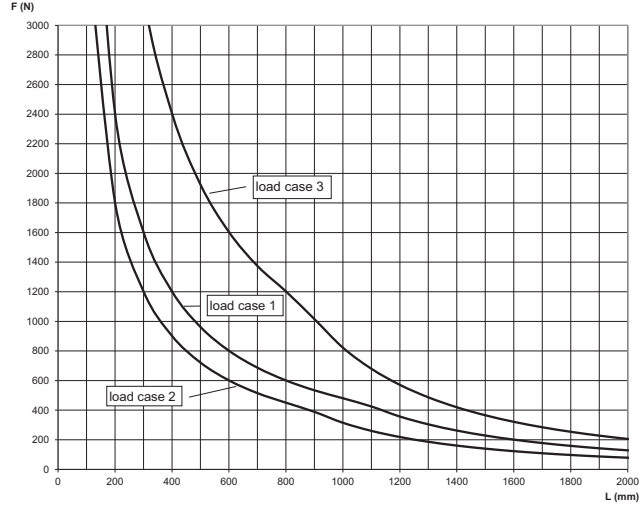

FLS 37/1.2

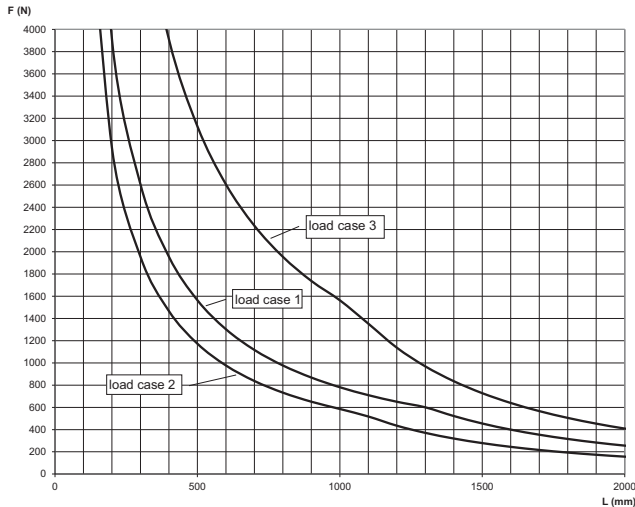

For the load curves, the permissible steel strain $\delta_{adm} = 188 \text{ N/mm}$ (increased steel strain due to bending) and the maximum deflection under load $L/200$ are not exceeded. Fixings and screw fastenings must be calculated accordingly. The higher yield strength is a result of the calculation according to DIN EN 1993-1-3:2010-12, para. 3.2.2.

Cantilever arm made from FLS channel profile



Pipe fixing at the wall

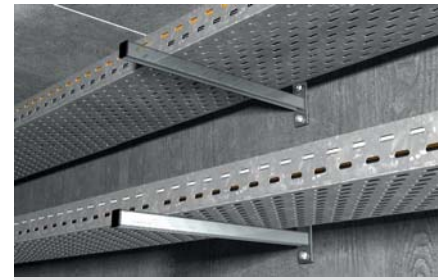

Cable tray on cantilever arm

APPLICATIONS

- The ALK cantilever arm allows the economic installation of single pipes or pipelines along the wall.

ADVANTAGES/BENEFITS

- The fire inspection report in line with MLAR/EN 1363-1 of the ALK 37 guarantees independently tested functional safety.
- The graduated range of lengths allows an ideal adaptation to the application.
- The console's stable base plate offers a secure hold for a load-bearing construction.
- The base plate's long slots, which are at 90° to one another, allow the console to be easily aligned.

CERTIFICATES



PROPERTIES

- Material Base plate:** steel E295 (material no.: 1.0050) acc. to DIN EN 10025-2
- Material Channel:** steel S2 15 G (material no.: 10116 G) acc. to DIN 1623
- Zinc plating:** electro zinc-plated, min. 13 μm

TECHNICAL DATA

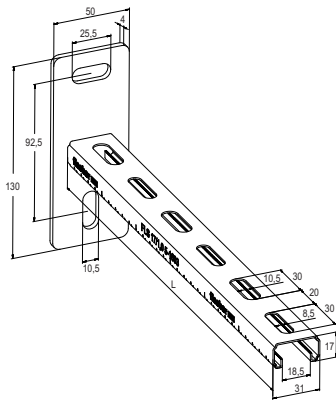

ALK 17

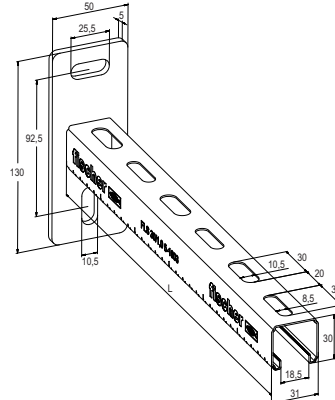

ALK 30

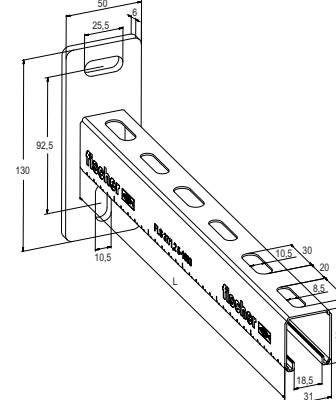

ALK 37

Item	Art.-No.	Fire test report	Profile	Length		Sales unit
				L	[mm]	
ALK 17-200	538738	—	17/1,0	200		10
ALK 17-300	538739	—	17/1,0	300		10
ALK 30-200	538740	—	30/1,0	200		10
ALK 30-300	538741	—	30/1,0	300		10
ALK 30-450	538742	—	30/1,0	450		10
ALK 37-300	538743	X	37/1,2	300		10
ALK 37-450	538744	X	37/1,2	450		10
ALK 37-600	538745	X	37/1,2	600		5

LOADS

Item	Art.-No.	Max. recommended static load load case 1 F_{rec} [kN]	Max. recommended static load load case 2 F_{rec} [kN]	Max. recommended static load load case 3 F_{rec} [kN]
ALK 17-200	538738	0.49	0.24	0.49
ALK 17-300	538739	0.33	0.12	0.31
ALK 30-200	538740	1.18	0.59	1.18
ALK 30-300	538741	0.79	0.39	0.79
ALK 30-450	538742	0.53	0.22	0.53
ALK 37-300	538743	1.27	0.64	1.27
ALK 37-450	538744	0.86	0.41	0.86
ALK 37-600	538745	0.63	0.24	0.63

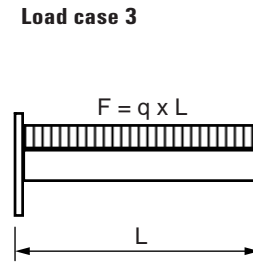
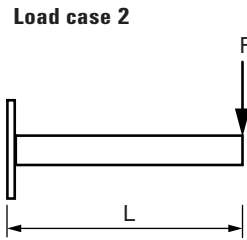
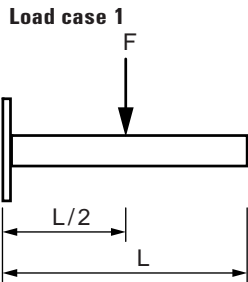

ALK 17/1.0

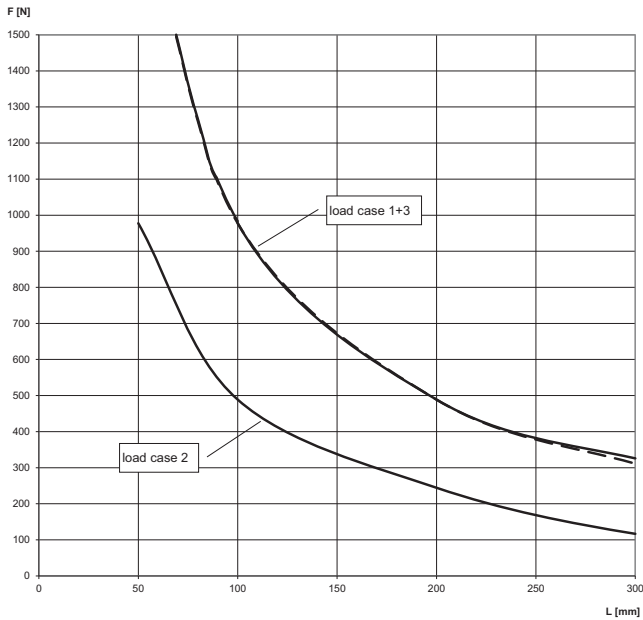

ALK 30/1.0

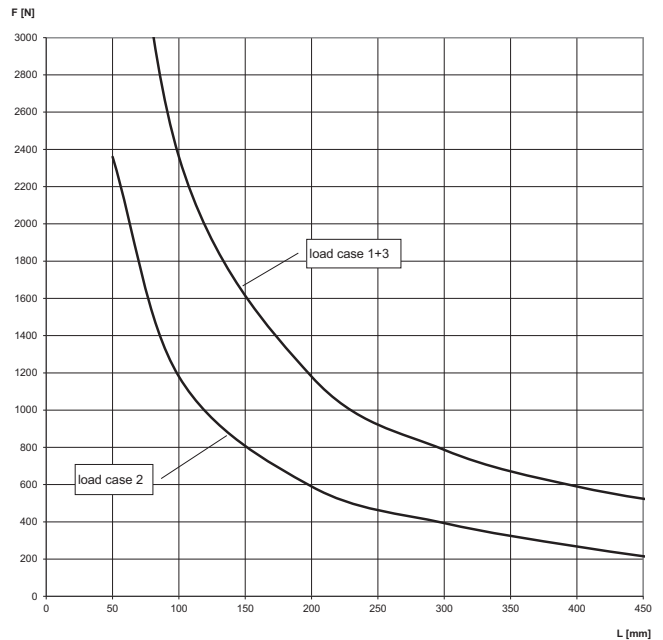

For the load curves, the permissible steel strain $\delta_{adm.} = 188 \text{ N/mm}^2$ (increased steel strain due to bending) and the maximum deflection under load $L/150$ are not exceeded. Fixings and screw fastenings must be calculated accordingly.

SEE ALSO

 **EMS**
Art.-No. 538752

ALK 37/1.2

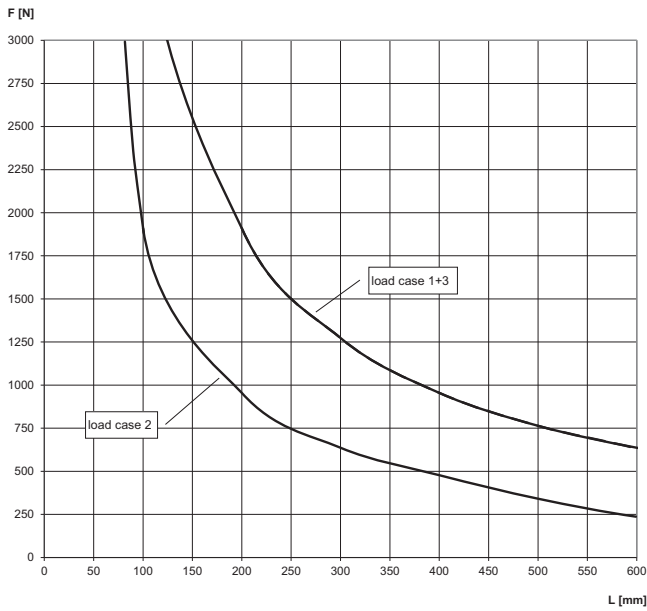

For the load curves, the permissible steel strain $\delta_{adm.} = 188 \text{ N/mm}^2$ (increased steel strain due to bending) and the maximum deflection under load $L/150$ are not exceeded. Fixings and screw fastenings must be calculated accordingly.

COVER CAP AK



AK 17



AK 30



AK 37

Item	Art.-No.	For profile	Material	Sales unit [pcs]
AK 17	538746	17/1.0	polypropylene	100
AK 30	538747	30/1.0	polypropylene	100
AK 37	538748	37/1.2	polypropylene	100

Angle brace for stable constructions



Cable tray on cantilever construction



Ventilating pipe fixing at the wall

APPLICATIONS

- Angle brace to construct self-supporting channel constructions with FLS channels or ALK cantilever arms.

ADVANTAGES/BENEFITS

- The stable angle brace element WS 31-45° lends the supporting structure a great stability and safety.
- The size of the angle brace element guarantees a secure connection with ALK cantilever arms and FLS channels by its fitting accuracy.
- The standardised long slots in the angle brace enable an exact connection to ALK cantilever arms or FLS channels by using FSM Clix P and a screw.

PROPERTIES

- **Material:** steel S235 JR (material no.: 1.0037) acc. to DIN EN 10025
- **Zinc plating:** electro zinc-plated, min. 5 µm acc. DIN EN ISO 4042



TECHNICAL DATA

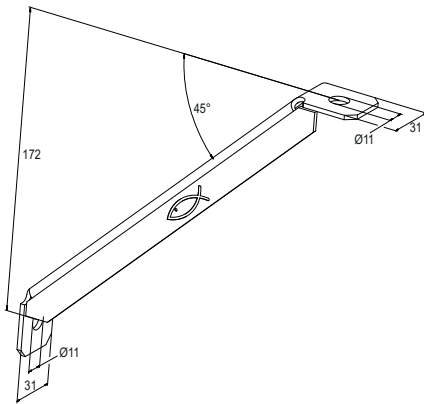

WS 31-45°

Item	Art.-No.	Eye Ø D [mm]	Sales unit [pcs]
WS 31-45°	538749	11	10

LOADS

Item	Art.-No.	Max. recommended static load load case 1a [kN]	Max. recommended static load load case 2a [kN]	Max. recommended static load load case 3a [kN]
ALK 17-200	538738	1.03	1.03	1.03
ALK 17-300	538739	1.52	0.45	1.52
ALK 30-200	538740	2.52	1.40	2.52
ALK 30-300	538741	1.78	0.89	1.78
ALK 30-450	538742	1.16	0.47	1.16
ALK 37-300	538743	1.78	0.89	1.78
ALK 37-450	538744	1.16	0.59	1.16
ALK 37-600	538745	0.89	0.45	0.89

Note: Loads are valid for fixing to wall with adequate carrying capacity. Fixing of the cantilever arm and the angle brace to the wall by anchor (e.g. FAZ II, FBS 8). Fixing of the angle brace to the cantilever profile by FSM Clix P 10, tightening torque 12 Nm. Fixing of the angle brace to the long slot of the cantilever profile by screw and nut M10, tightening torque 20 Nm.

Load case 1a

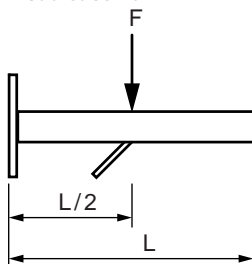

Load case 2a

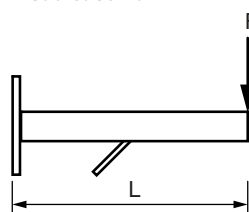

Load case 3a

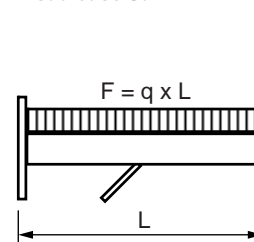

Construction element - Channel connector SV 31

Installation system FLS

3



Channel extension with channel connector

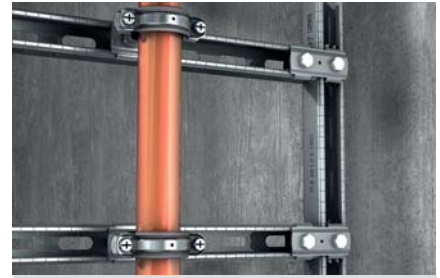

Vertical installation

APPLICATIONS

- With the channel connector SV 31 FLS channels can be connected in different directions.

ADVANTAGES/BENEFITS

- The special retaining brackets at the SV construction elements enable a form-locking installation longitudinal and transverse to the channel direction to adapt the channel connection effectively
- The standardised long slots of the channel connector enable an exact connection to ALK cantilever arms or FLS channels by using FSM Clix P and a screw

PROPERTIES

- **Material:** steel S235 JR+CR (material no.: 1.0037) acc. to DIN EN 1652
- **Zinc plating:** electro zinc-plated, min. 5 µm acc. DIN EN ISO 4042

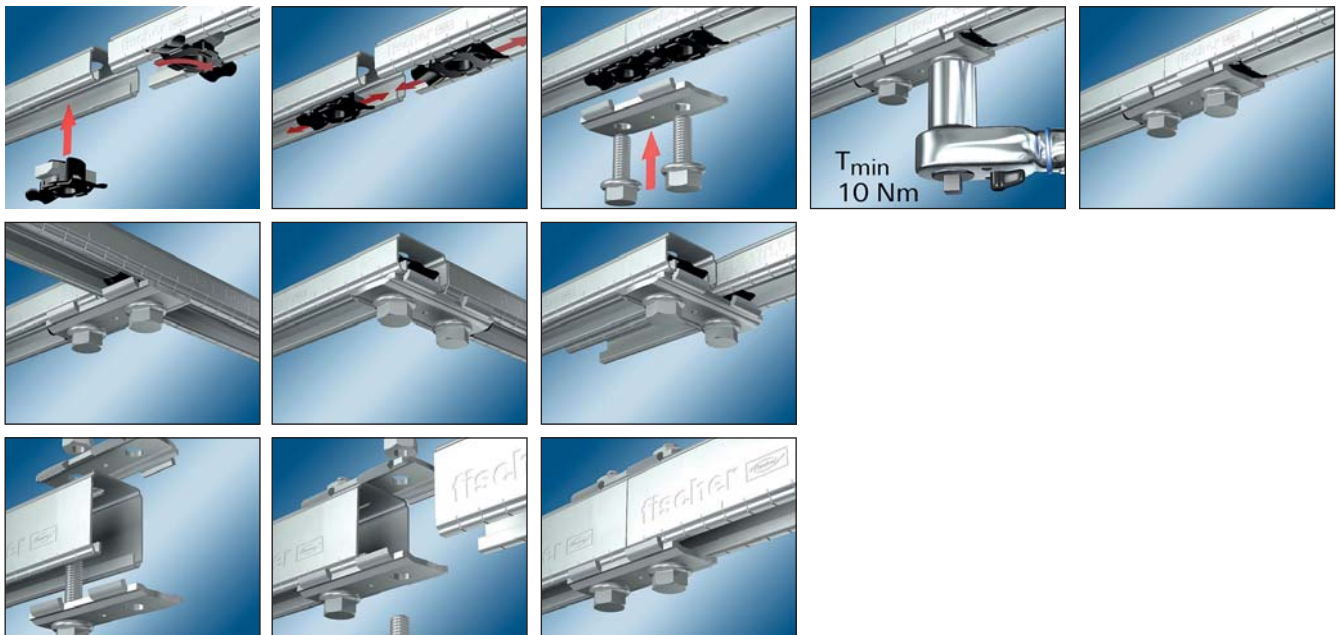

TECHNICAL DATA

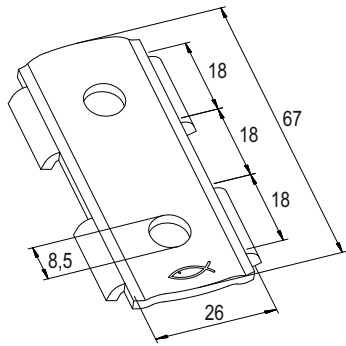

Item	Art.-No.	Hole diameter	Sales unit
		D [mm]	[pcs]
SV 31	538641	8.5	25

LOADS

Item	Art.-No.	Max. recommended shear load	Tightening torque
		V_{rec} [kN]	T_{inst} [Nm]
SV 31	538641	1.0	10

The loads are only valid by using FSM Clix P 8.

Channel nut for quick and easy connection of FLS channels



Channel fixing to the floor



Channel extension with channel connector

APPLICATIONS

- FSM Clix P is suitable for interconnecting FLS channels by using connecting elements.

ADVANTAGES/BENEFITS

- The special and disappearing thrust block of the sliding nut Clix P plastic holder enables a connection of connecting elements and channels without plastic interlayer to establish a safe longitudinal metallic connection.
- The especially developed spring leg on the FSM Clix P guarantees the necessary contact pressure of the connector to the channel to help for a secure adjustment during installation.
- The teeth on the sliding nut enable an exact and secure positioning in the FLS channel and ease the installation of connector elements.
- The unique stop element on the FSM Clix P connector guarantees the accurate 90°-turn of the connectors in the channel to ensure a save and precise installation.

CERTIFICATES



PROPERTIES

- Material channel nut:** steel S420MC (material no.: 1.0980) acc. DIN EN 10149-2
- Material plastic cage:** polypropylene PP, item number 11400, Color black
- Zinc plating:** electro zinc-plated, min. 5 µm acc. DIN EN ISO 4042



TECHNICAL DATA

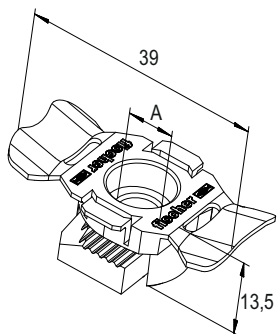

Item	Art.-No.	Thread	Sales unit
		A	[pcs]
FSM Clix P 6	538643	M 6	50
FSM Clix P 8	538647	M 8	50
FSM Clix P 10	538649	M 10	50

LOADS

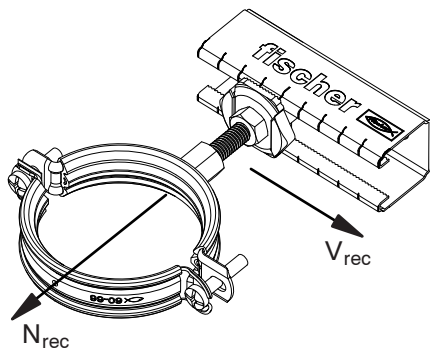

Item	Art.-No.	Max. recommended tension load for FLS 17/1.0 and FLS 30/1.0	Max. recommended tension load for FLS 37/1.2	Max. recommended shear load	Tightening torque
		N_{rec} [kN]	N_{rec} [kN]	V_{rec} [kN]	T_{inst} [Nm]
FSM Clix P 6	538643	1.5	2.0	1.0	10
FSM Clix P 8	538647	1.5	2.0	1.0	10
FSM Clix P 10	538649	1.5	2.0	1.0	10

Channel nut for quick and easy fixing in FLS channels



Pipe fixing with channel



Pipe fixing on frame construction

APPLICATIONS

- FSM Clix M is suitable for connecting pipe clamps with a threaded rod to FLS channels.

ADVANTAGES/BENEFITS

- The unique spring leg at the FSM Clix M guarantees the necessary contact pressure of the connector to the channel to help for a secure adjustment during installation.
- The teeth on the sliding nut enable an exact and secure positioning in the FLS channel and ease the installation of connector elements.
- The clix-connector element with 90°-turn for connecting enables an easy post-installation in set channels to save time and money.
- The especially developed stop element on the FSM Clix M connector guarantees the accurate 90°-turn of the connectors in the channel to ensure a safe and precise installation.

CERTIFICATES



PROPERTIES

- Material channel nut:** steel S420MC (material no.: 1.0980) acc. DIN EN 10149-2
- Material cover plate:** steel S235JR+CR (material no.: 1.0037) acc. DIN 1652
- Material plastic cage:** polypropylene PP, item number 11400, Color black
- Zinc plating:** electro zinc-plated, min. 5 µm acc. DIN EN ISO 4042



TECHNICAL DATA

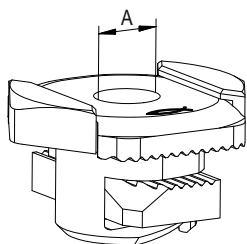

Item	Art.-No.	Thread	Width across nut	Sales unit
		A	○ SW [mm]	[pcs]
FSM Clix M 6	538650	M 6	10	50
FSM Clix M 8	538651	M 8	13	50
FSM Clix M 10	538652	M 10	17	50

LOADS

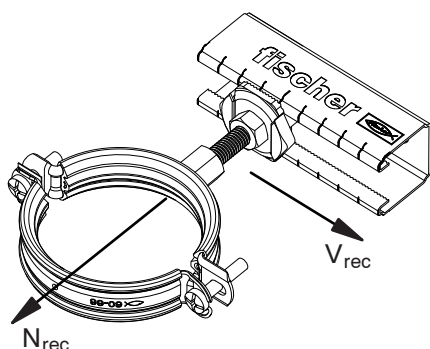

Item	Art.-No.	Max. recommended tension load for FLS 17/1.0 and FLS 30/1.0	Max. recommended tension load for FLS 37/1.2	Max. recommended shear load	Tightening torque
		N_{rec} [kN]	N_{rec} [kN]	V_{rec} [kN]	T_{inst} [Nm]
FSM Clix M 6	538650	1.5	2.0	1.0	8
FSM Clix M 8	538651	1.5	2.0	1.0	8
FSM Clix M 10	538652	1.5	2.0	1.0	8

Hammer-head bolt for quick and easy fixing in FLS channels



APPLICATIONS

- FHS Clix is suitable for connecting pipe clamps with the channel.

ADVANTAGES/BENEFITS

- The special spring leg at the FHS Clix guarantees the necessary contact pressure of the connector to the channel to help for a secure adjustment during installation.
- The teeth on the sliding nut enable an exact and secure positioning in the FLS channel and ease the installation of connector elements.
- The clix-connector element with 90°-turn for connecting enables an easy post-installation in set channels to save time and money.
- The especially developed stop element on the FHS Clix connector guarantees the accurate 90°-turn of the connectors in the channel to ensure a safe and precise installation.

CERTIFICATES



PROPERTIES

- **Material channel nut:** steel S420MC (material no.: 1.0980) acc. DIN EN 10149-2
- **Material cover plate:** steel S235JR+CR (material no.: 1.0037) acc. DIN 1652
- **Material threaded rod:** steel acc. DIN 976-2, min. 4.6 (DIN EN ISO 898-1)
- **Material hexagonal nut:** steel acc. DIN 934-4 min. 4.8 (DIN EN ISO 898-2 table 4 stability)
- **Material plastic cage:** polypropylene PP, item number 11400, Color black
- **Zinc plating:** electro zinc-plated, min. 5 µm acc. DIN EN ISO 4042



TECHNICAL DATA

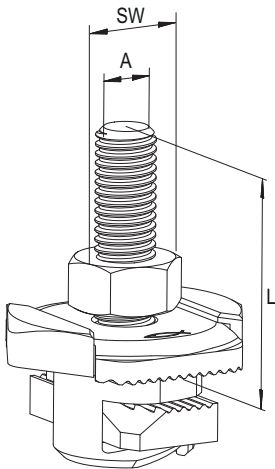

Item	Art.-No.	Thread	Length	Width across nut	Sales unit
		A	L [mm]	○ SW [mm]	
FHS CLIX 8 x 30	538653	M 8	30	13	100
FHS CLIX 8 x 40	538654	M 8	40	13	100
FHS CLIX 8 x 60	538655	M 8	60	13	100
FHS CLIX 8 x 80	538656	M 8	80	13	50
FHS CLIX 8 x 100	538657	M 8	100	13	50
FHS CLIX 10 x 30	538658	M 10	30	17	100
FHS CLIX 10 x 40	538659	M 10	40	17	100
FHS CLIX 10 x 60	538660	M 10	60	17	50
FHS CLIX 10 x 100	538661	M 10	100	17	50

LOADS

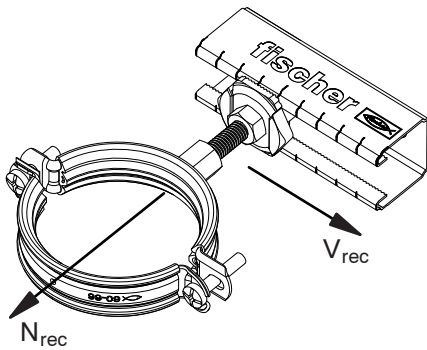

Item	Art.-No.	Max. recommended tension load for FLS 17/1.0 and FLS 30/1.0	Max. recommended tension load for FLS 37/1.2	Max. recommended shear load	Tightening torque
		N_{rec} [kN]	N_{rec} [kN]	V_{rec} [kN]	T_{inst} [Nm]
FHS CLIX 8 x 30	538653	1.5	2.0	1.0	8
FHS CLIX 8 x 40	538654	1.5	2.0	1.0	8
FHS CLIX 8 x 60	538655	1.5	2.0	1.0	8
FHS CLIX 8 x 80	538656	1.5	2.0	1.0	8
FHS CLIX 8 x 100	538657	1.5	2.0	1.0	8
FHS CLIX 10 x 30	538658	1.5	2.0	1.0	8
FHS CLIX 10 x 40	538659	1.5	2.0	1.0	8
FHS CLIX 10 x 60	538660	1.5	2.0	1.0	8
FHS CLIX 10 x 100	538661	1.5	2.0	1.0	8

The pre-assembled saddle flange SF Clix 31

3

Installation system FLS



Channel installation at the wall



Cantilever construction with channel

APPLICATIONS

- Element for the stable construction of connections between channels and building structures.

ADVANTAGES/BENEFITS

- Pre-assembled accessories like SF Clix bring the number of articles for a connection down and guarantee a time-saving installation.
- The pre-assembled connector of the SF Clix secures the installation position due to the unique thrust block and guarantees a safe and fast installation.
- The special spring leg at pre-assembled connector guarantees the necessary contact pressure of the connector to the channel to help for a secure adjustment during installation.
- The perfect-fit saddle of the SF allows an simple installation by inserting the channel.
- The saddle flange's stable design offers a secure hold for a load-bearing construction.

PROPERTIES

- **Material saddle:** steel E295 (material no.: 1.0050) acc. DIN EN 10025-2
- **Material channel nut:** steel S420MC (material no.: 1.0980) acc. DIN EN 10149-2
- **Material cover plate:** steel S235JR+CR (material no.: 1.0037) acc. DIN 1652
- **Material hexagonal screw:** steel min. 4.6 (DIN EN ISO 898-1)
- **Material plastic cage:** polypropylene PP, item number 11400, Color black
- **Zinc plating:** electro zinc-plated, min. 5 µm, hexagonal screw min. 3 µm acc. DIN EN ISO 4042

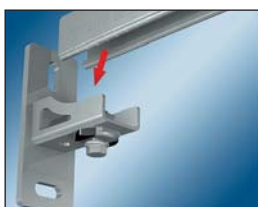

TECHNICAL DATA

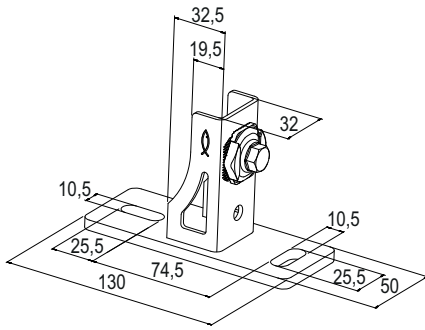

Item	Art.-No.	Thread A	Width across nut ○ SW [mm]	Sales unit [pcs]
SF Clix 31	538665	M 8	13	10

LOADS

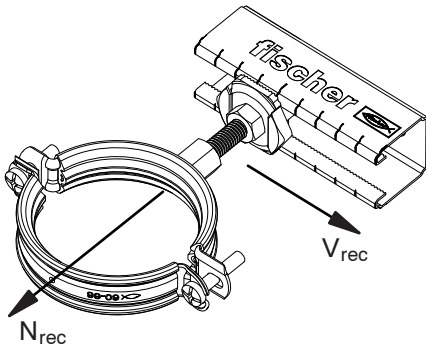

Item	Art.-No.	Max. recommended tension load for FLS 17/1.0 and FLS 30/1.0 N_{rec} [kN]	Max. recommended tension load for FLS 37/1.2 N_{rec} [kN]	Max. recommended shear load V_{rec} [kN]	Tightening torque T_{inst} [Nm]
SF Clix 31	538665	1.5	2.0	1.0	10

Max. recommended shear load: By using additional screw M8 the shear load for vertical installation can be doubled.

The pre-assembled angle bracket MW Clix 90°

3

Installation system FLS



Cantilever construction with channel



Pipe fixing on frame construction

APPLICATIONS

- Element for the stable construction of angle connections with FLS channels.

ADVANTAGES/BENEFITS

- Pre-assembled accessories like SF Clix bring the number of articles for a connection down and guarantee a time-saving installation.
- The pre-assembled connector of the MW Clix secures the installation position due to the unique thrust block and guarantees a safe and fast installation.
- The especially developed spring leg at the pre-assembled connector guarantees the necessary contact pressure of the connector to the channel to help for a secure adjustment during installation.
- The form-locking and accurately fitting angle bracket of the MW clix allows a simple installation of the FLS channel and saves valuable installation time.

PROPERTIES

- **Material angle bracket:** steel S235JR+CR (material no.: 1.0037) acc. DIN 1652
- **Material channel nut:** steel S420MC (material no.: 1.0980) acc. DIN EN 10149-2
- **Material cover plate:** steel S235JR+CR (material no.: 1.0037) acc. DIN 1652
- **Material hexagonal screw:** steel min. 4.6 (DIN EN ISO 898-1)
- **Material plastic cage:** polypropylene PP, item number 11400, Color black
- **Zinc plating:** electro zinc-plated, min. 5 µm, hexagonal screw min. 3 µm acc. DIN EN ISO 4042



T_{min}
10 Nm

TECHNICAL DATA

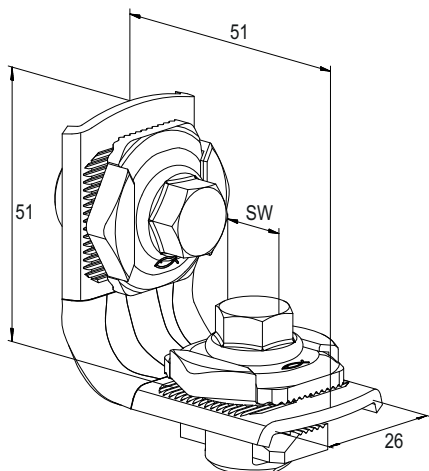

Item	Art.-No.	Thread A	Width across nut ○ SW [mm]	Sales unit [pcs]
MW Clix 90°	538666	M 8	13	10

LOADS

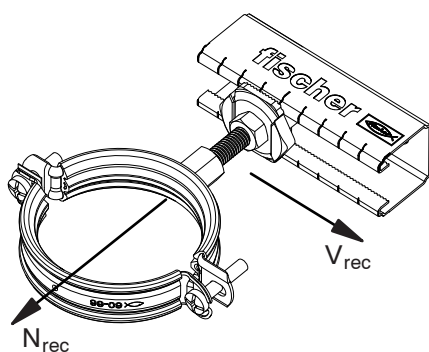

Item	Art.-No.	Max. recommended tension load for FLS 17/1.0 and FLS 30/1.0 N_{rec} [kN]	Max. recommended tension load for FLS 37/1.2 N_{rec} [kN]	Max. recommended shear load V_{rec} [kN]	Tightening torque T_{inst} [Nm]
MW Clix 90°	538666	1.5	2.0	1.0	10

Construction element – Angle bracket MW 90° and MWU 90°



Channel fixing to the floor



Pipe fixing in a corridor

APPLICATIONS

- Connecting elements for the arrangement of simple channel constructions with the sliding channel nut FSM Clix P.

ADVANTAGES/BENEFITS

- The individual developed retaining brackets at the MW 90° angle bracket enable a form-locking installation longitudinal and transverse to the channel direction to adapt the channel connection effectively.
- The long slot on flat wing of the MWU 90° angle bracket enables a direct connection to the substrate for space-saving fixation.
- The standardised holes in the angle brackets enable an exact connection to the FLS channels by using FSM Clix P and a screw.

PROPERTIES

- **Material:** steel S235 JR+CR (material no.: 1.0037) acc. to DIN EN 1652
- **Zinc plating:** electro zinc-plated, min. 5 µm acc. DIN EN ISO 4042

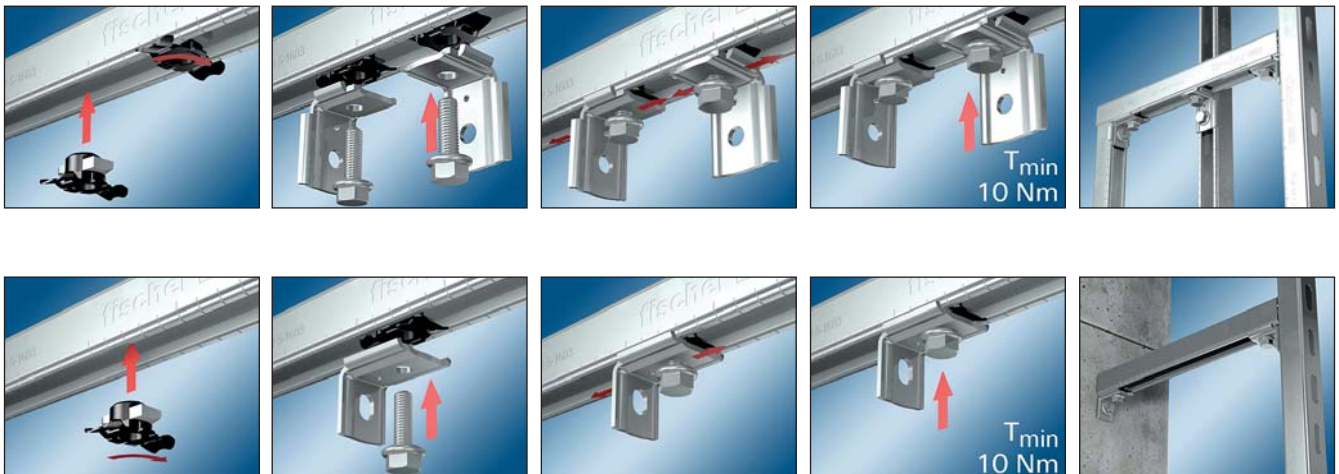

TECHNICAL DATA

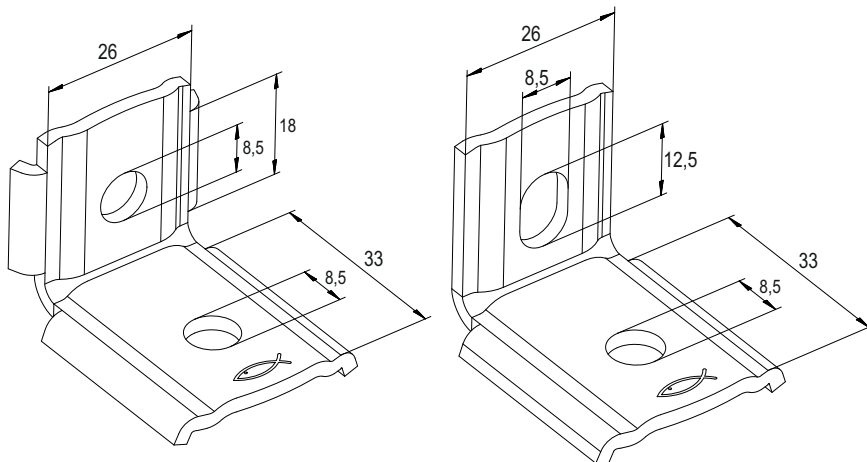

MW 90°

MWU 90°

Item	Art.-No.	Hole diameter	Sales unit
		D [mm]	[pcs]
MW 90°	538668	8.5	50
MWU 90°	538667	8.5	25

LOADS

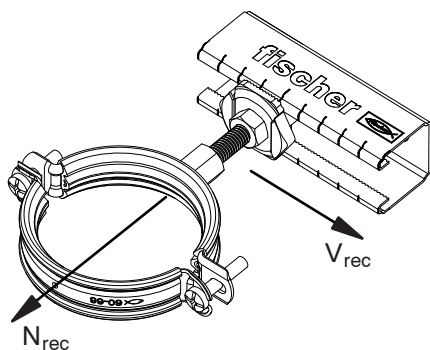

Item	Art.-No.	Max. recommended tension load for FLS 17/1.0 and FLS 30/1.0	Max. recommended tension load for FLS 37/1.2	Max. recommended shear load	Tightening torque
		N_{rec} [kN]	N_{rec} [kN]	V_{rec} [kN]	T_{inst} [Nm]
MW 90°	538668	1.5	2.0	1.0	10
MWU 90°	538667	1.5	2.0	1.0	10

The loads are only valid by using FSM Clix P 8.

Connector - Channel washer HK 31



Pipe fixing with channel



Horizontal pipe fixing

APPLICATIONS

The Channel washer HK 31 is used for stable connections and to strengthen the profile for a fixing to the substrate.

ADVANTAGES/BENEFITS

- The special retaining brackets at the SV connecting elements enable a form-locking installation longitudinal and transverse to the channel direction to adapt the channel connection effectively.
- The standardised slots of the Channel washer enable an exact push-through connection of FLS mounting channels easy and fast.

CERTIFICATES



PROPERTIES

- **Material:** steel S235 JR+CR (material no.: 1.0037) acc. to DIN EN 1652
- **Zinc plating:** electro zinc-plated, min. 5 µm acc. DIN EN ISO 4042

TECHNICAL DATA

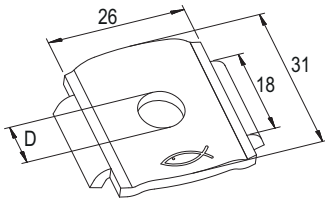

Item	Art.-No.	Hole diameter	Sales unit
		D [mm]	[pcs]
HK 31 8,5	538663	8.5	50
HK 31 10,5	538664	10.5	50

Clamping bracket for the fixing of channels to steel girders



3

Installation system FLS

APPLICATIONS

- Fixing of FLS channels to steel girders, required are two beam clamps per fixing.

ADVANTAGES/BENEFITS

- The design of the beam clamp allows for fixing without drilling or welding.
- The various lengths of the beam clamp sides allows for fixing on all standard steel beams.
- The shape of the beam clamp guarantees the simple adjustment of the channel connection.

PROPERTIES

- Material U-bolt pipe hanger:** steel S235 JR (material no.: 1.0037) acc. DIN EN 10025-2
- Material plate:** steel E295 (material no.: 1.0050) acc. DIN EN 10025-2
- Material hexagon nut:** steel resistance class 8
- Zinc plating:** electro zinc-plated, min. 5 µm acc. DIN EN ISO 4042

TECHNICAL DATA

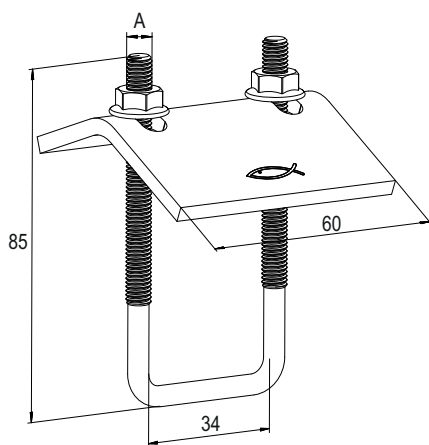

Item	Art.-No.	Thread A	Width across nut ○ SW [mm]	Sales unit [pcs]
TKR 31	538751	M 6	10	25

LOADS

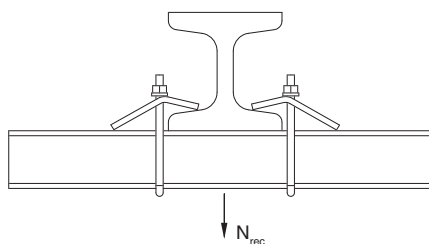

Item	Art.-No.	Max. recom. static load (centr. tension) $N_{recom.}$ [kN]	Tightening torque T_{inst} [Nm]
TKR 31	538751	2.80	5



4

Installation system FUS

	page		page		page
Channels		Construction elements		Saddle flange SF	
Channel FUS	114	Channel connector FUF OC and PFUF OC	119	Mounting bracket UWS	145
Cantilever		Saddle flange PSF	128	Mounting bracket FAF	153
Cantilever arm FCA	120	Universal bracket PUWS	129	Flanges FZF	154
Large cantilever arm FCAM	124	Angle bracket PWK	130	Bracket FFF	152
Cover cap FEC	125	Variable bracket PVB	131	Variable bracket VB	149
Connectors		Bracing elements PSAE	132	Threaded rod bracket FSB 45°	150
Push-through connector PFCN 41	126	Bracket PFFF	134	Universal mounting UHRS	148
Connector FCN Clix P and FCN Clix M	138	Bracket PFAF	135	Beam clamp TKR	151
T-head bolt FHS Clix S	140	Bracket PFUF	136		
Channel nut FCN	142	Brackets PFUF D	137		
Channel washer HK 41	143				

The universal and complete mounting channel system for a wide range of applications

Installation system FUS

4



3D-frame constructions



Solid frame construction

Applications

- Secure horizontal and vertical installations
- Fast and efficient fixing of pipelines and supporting structures

Advantages/benefits

- The fire inspection report in line with MLAR/EN13501 guarantees independently tested functional safety.
- The basic channel geometry allows the usage of the complete extensive range of accessories.
- The stamped teeth in the channel give the sliding nuts a secure hold for high shear loads, e.g. for vertical installation.
- Different channel wall thicknesses allow economical choices for installation.
- The scale on the mounting channels simplifies the cutting and positioning of the fixtures during the installation.

Certificates



Properties

- **Material:** steel S250 GD (material no. 1.0242) acc. to DIN EN 10346
- **Zinc plating:** sendzimir-galvanised, app. 20 µm

SEE ALSO



FCN Clix P/M
see page 138



EMS
see page 184

TECHNICAL DATA

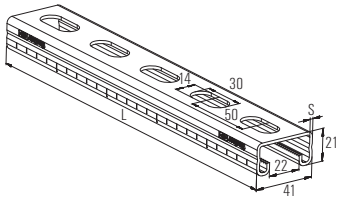

FUS 21

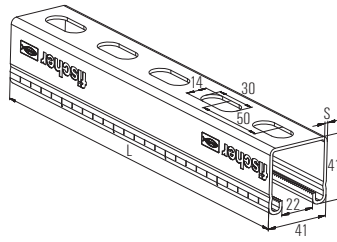

FUS 41

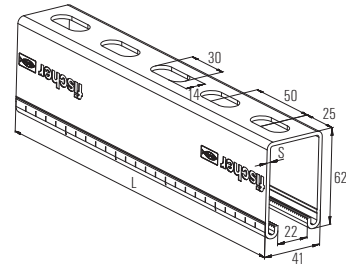

FUS 62

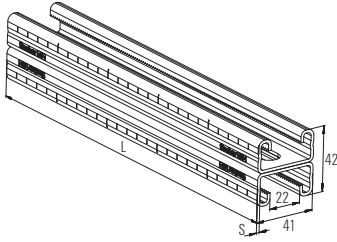

FUS 21D

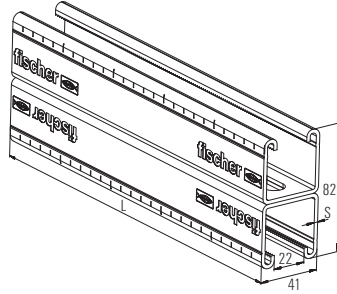

FUS 41D

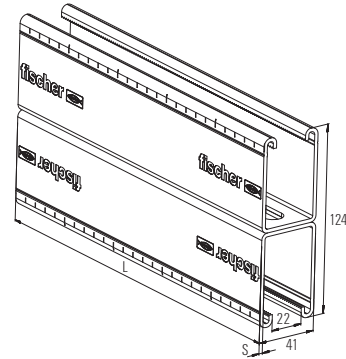

FUS 62D

Item	Art.-No.	Fire test report	Length		Thickness		Sales unit
			L [mm]	S [mm]	S [mm]	[pcs]	
FUS 21/2,0 - 2 m	040391	—	2000	2	2	1	
FUS 21/2,0 - 3 m	097660	—	3000	2	2	1	
FUS 21/2,0 - 6 m	097661	—	6000	2	2	1	
FUS 21/2,5 - 2 m	092867	—	2000	2.5	2.5	1	
FUS 21/2,5 - 3 m	077349	—	3000	2.5	2.5	1	
FUS 21/2,5 - 6 m	077541	—	6000	2.5	2.5	1	
FUS 41/2,0 - 2 m	040390	—	2000	2	2	1	
FUS 41/2,0 - 3 m	097658	—	3000	2	2	1	
FUS 41/2,0 - 6 m	097659	—	6000	2	2	1	
FUS 41/2,5 - 2 m	092295	X	2000	2.5	2.5	1	
FUS 41/2,5 - 3 m	077347	X	3000	2.5	2.5	1	
FUS 41/2,5 - 6 m	077537	X	6000	2.5	2.5	1	
FUS 62/2,5 - 6 m	504457	X	6000	2.5	2.5	1	
FUS 21D/2,0 - 3 m	504458	—	3000	2	2	1	
FUS 21D/2,0 - 6 m	535531	—	6000	2	2	1	
FUS 41D/2,5 - 6 m	504459	—	6000	2.5	2.5	1	
FUS 62D/2,5 - 6 m	504460	—	6000	2.5	2.5	1	

LOADS

Item	Art.-No.	Profil weight [kg/m]	Profile cross section [cm ²]	Moment of inertia I_y [cm ⁴]	Moment of inertia I_z [cm ⁴]	Section modulus W_y [cm ³]	Section modulus W_z [cm ³]	Max. recommended static load for	Max. recommended static load for	Max. recommended static load for
								1m length F_{rec} [kN]	2m length F_{rec} [kN]	3m length F_{rec} [kN]
FUS 21/2,0 - 2 m	040391	1.44	1.72	0.97	4.66	0.89	2.27	0.49	0.12	0.05
FUS 21/2,0 - 3 m	097660	1.44	1.72	0.97	4.66	0.89	2.27	0.49	0.12	0.05
FUS 21/2,5 - 2 m	092867	1.67	1.99	1.03	5.28	0.93	2.58	0.52	0.13	0.06
FUS 21/2,5 - 3 m	077349	1.67	1.99	1.03	5.28	0.93	2.58	0.52	0.13	0.06
FUS 21/2,5 - 6 m	077541	1.67	1.99	1.03	5.28	0.93	2.58	0.52	0.13	0.06
FUS 41/2,0 - 2 m	040390	2.06	2.52	5.33	7.69	2.58	3.75	1.94	0.67	0.30
FUS 41/2,0 - 3 m	097658	2.06	2.52	5.33	7.69	2.58	3.75	1.94	0.67	0.30
FUS 41/2,0 - 6 m	097659	2.06	2.52	5.33	7.69	2.58	3.75	1.94	0.67	0.30
FUS 41/2,5 - 2 m	092295	2.45	3.00	6.00	8.99	2.85	4.38	2.14	0.76	0.34
FUS 41/2,5 - 3 m	077347	2.45	3.00	6.00	8.99	2.85	4.38	2.14	0.76	0.34
FUS 41/2,5 - 6 m	077537	2.45	3.00	6.00	8.99	2.85	4.38	2.14	0.76	0.34
FUS 62/2,5 - 6 m	504457	3.27	4.05	17.70	12.90	5.62	6.29	4.22	2.10	0.99
FUS 21D/2,0 - 3 m	504458	2.87	3.44	5.49	9.31	2.61	4.54	1.96	0.69	0.31
FUS 21D/2,0 - 6 m	535531	2.87	3.44	5.49	9.31	2.61	4.54	1.96	0.69	0.31
FUS 41D/2,5 - 6 m	504459	4.89	6.00	35.01	17.90	8.76	8.78	6.58	3.28	1.96
FUS 62D/2,5 - 6 m	504460	6.55	8.09	111.00	25.80	17.90	12.58	13.45	6.72	4.47

Load case 1

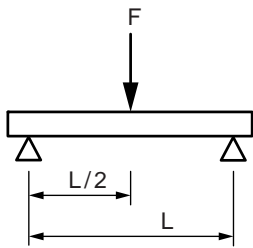

Load case 2

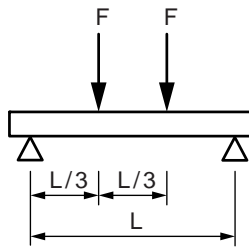

Load case 3

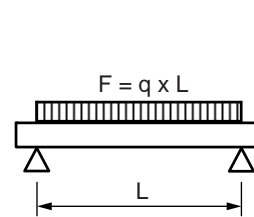

FUS 21 / 2.0

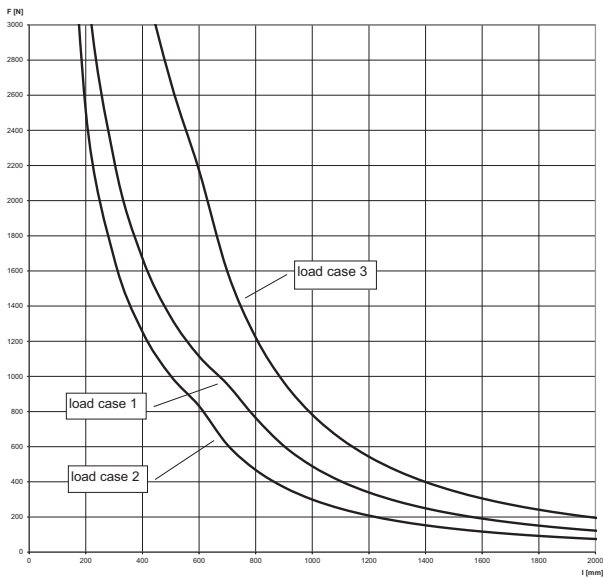

FUS 21 / 2.5

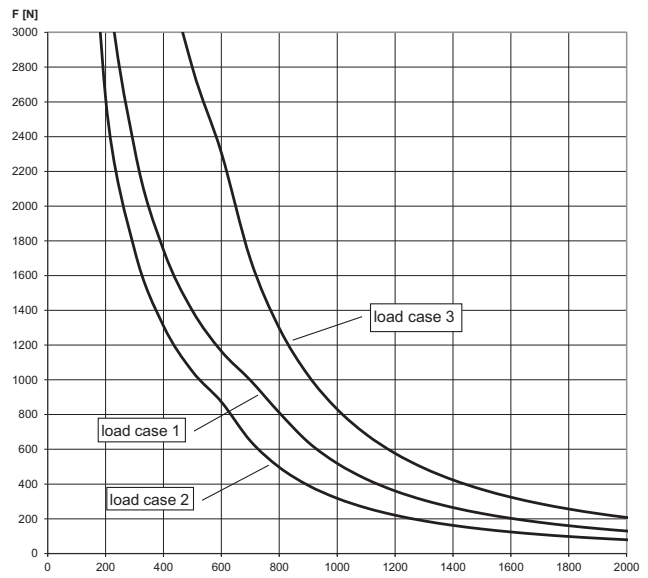

For the load curves, the permissible steel strain $\delta_{adm} = 188 \text{ N/mm}$ and the maximum deflection under load $L/200$ are not exceeded. Fixings and screw fastenings must be calculated accordingly. The increased yield strength is calculated according DIN EN 1993-1-3:2010-12, sec. 3.2.2.

FUS 41 / 2.0

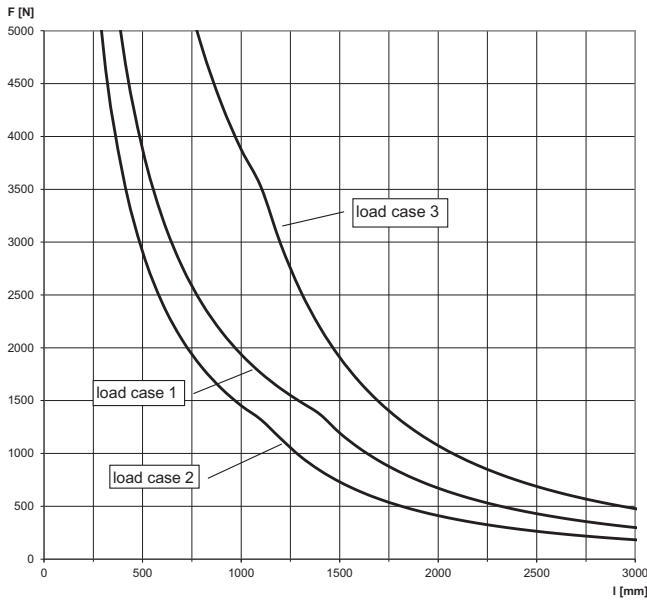

FUS 41 / 2.5

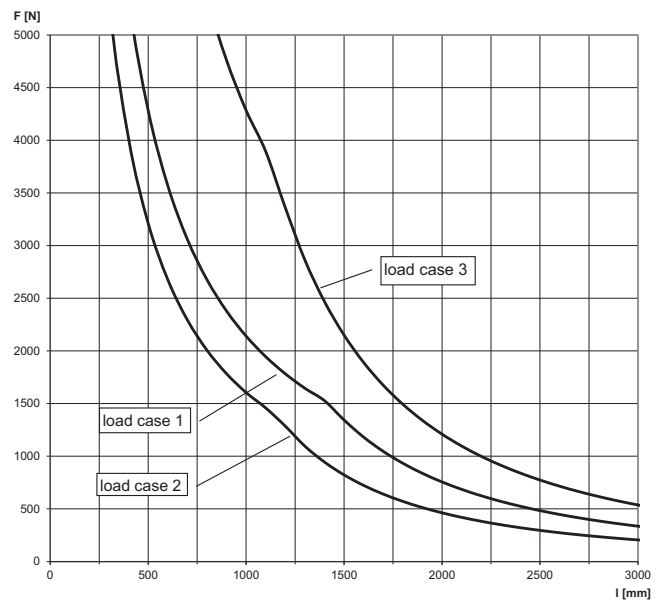

For the load curves, the permissible steel strain $\delta_{adm.} = 188$ N/mm and the maximum deflection under load $L/200$ are not exceeded. Fixings and screw fastenings must be calculated accordingly. The increased yield strength is calculated according DIN EN 1993-1-3:2010-12, sec. 3.2.2.

FUS 62 / 2.5

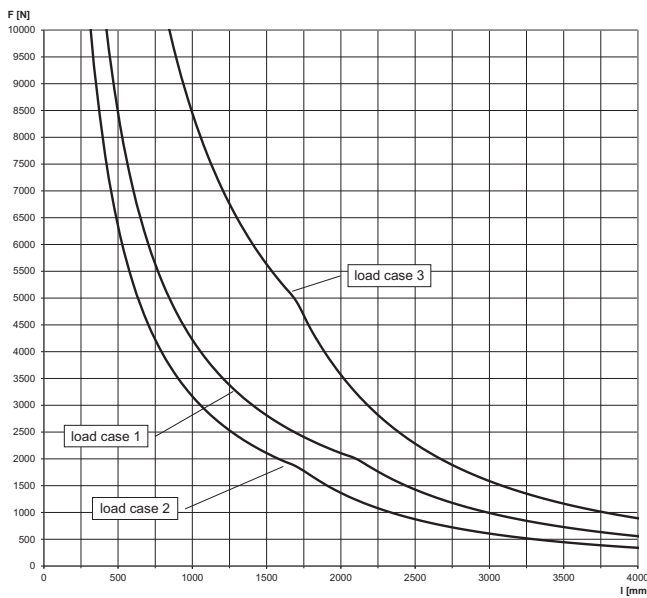

FUS 21D / 2.0

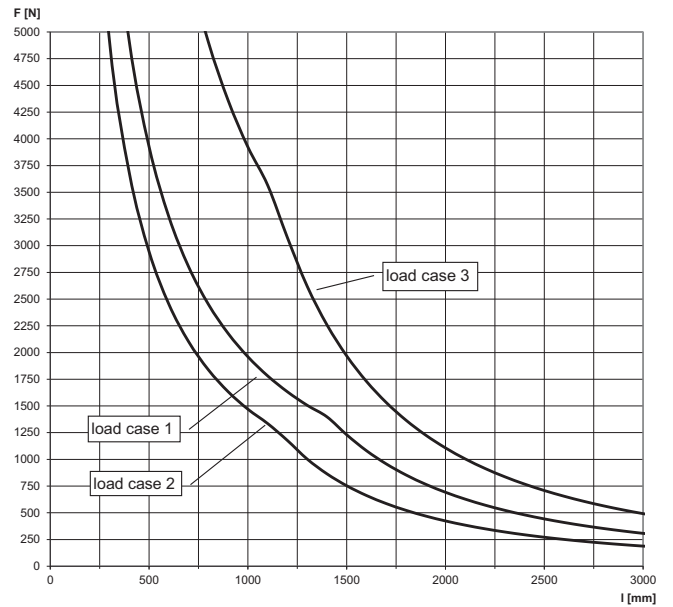

For the load curves, the permissible steel strain $\delta_{adm.} = 188$ N/mm and the maximum deflection under load $L/200$ are not exceeded. Fixings and screw fastenings must be calculated accordingly. The increased yield strength is calculated according DIN EN 1993-1-3:2010-12, sec. 3.2.2.

FUS 41D / 2.5

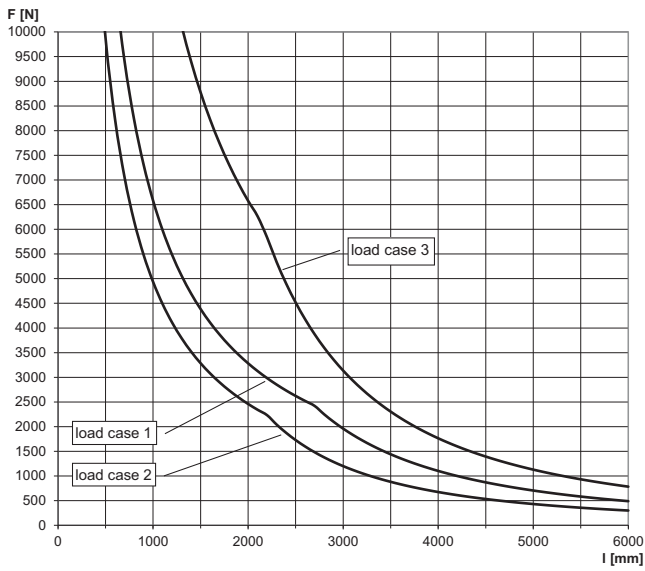

FUS 62D / 2.5

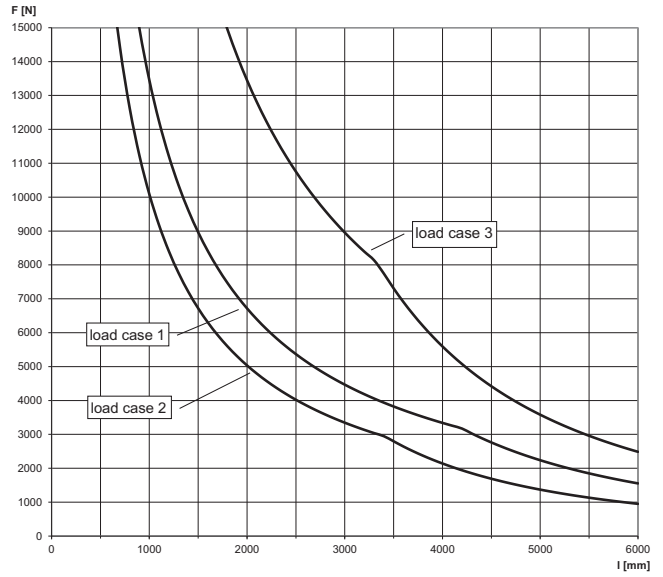

For the load curves, the permissible steel strain $\delta_{adm} = 188 \text{ N/mm}$ and the maximum deflection under load $L/200$ are not exceeded. Fixings and screw fastenings must be calculated accordingly. The increased yield strength is calculated according to DIN EN 1993-1-3:2010-12, sec. 3.2.2.

Construction element - Channel connector FUF OC and PFUF OC



Connector for installation grid



Longitudinal channel connection

APPLICATIONS

- Connection and precise alignment of channel

ADVANTAGES/BENEFITS

- The FUF OC connector in combination with FCN Clix P allows a simple and time-saving installation.
- The PFUF OC connector in combination with PFCN allows a simple and time-saving installation.

PROPERTIES

- **Material FUF OC:** steel S235 JR (material no. 1.0037) acc. to DIN EN 10025
- **Zinc plating FUF OC:** electro zinc-plated, min. 5 µm
- **Material PFUF OC:** steel DD11 (material no. 1.0332) acc. to DIN EN 10111
- **Zinc plating PFUF OC:** electro zinc-plated acc. DIN 50979, min. 8 µm

TECHNICAL DATA

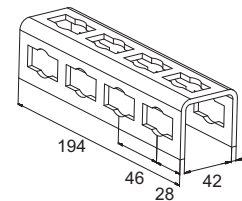
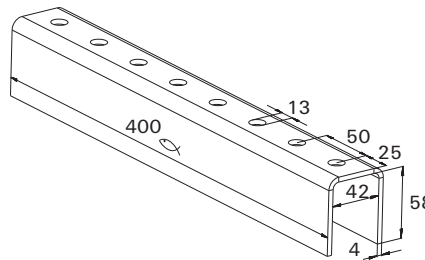
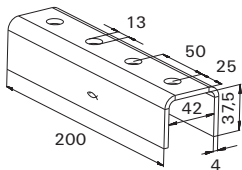

FUF OC 41

FUF OC 62

PFUF OC

Item	Art.-No.	Length [mm]	Sales unit [pcs]		
FUF OC 41	504517	200	20		
FUF OC 62	504518	400	10		
PFUF OC	533743	194	6		

FUS profiles with welded base plate for direct mounting on the base material

4 Installation system FUS



Refrigerant pipe clamp on sliding element

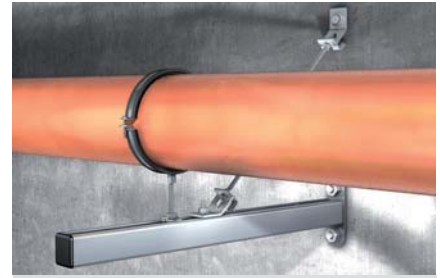

Heavy pipe on cantilever

APPLICATIONS

- Quick and easy installation of pipelines (e.g. along the wall)

ADVANTAGES/BENEFITS

- The fire inspection report in line with MLAR/EN13501 guarantees independently tested functional safety.
- The graduated range of lengths allows for an ideal adaptation to the application.
- The arm's solid base plate offers a secure hold for load-bearing construction.
- The base plate's long slots, which are at 90° to one another, allow the arm to be easily aligned.
- The stamped teeth in the channel gives the sliding nuts a secure hold for high shear loads, e.g. for vertical installation.

CERTIFICATES



PROPERTIES

- **Material:** steel S235 JR (material no.10037) acc. to DIN EN 10025
- **Zinc plating:** electro zinc-plated, min. 10 µm

TECHNICAL DATA

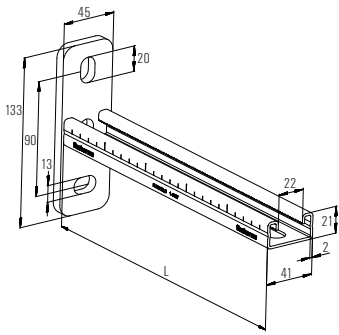

FCA 21

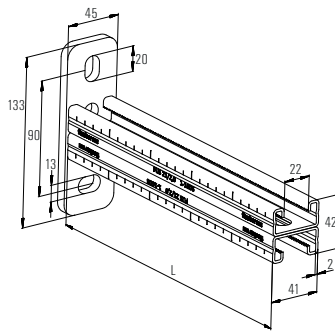

FCA 21D

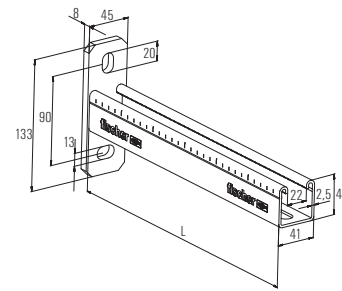

FCA 41

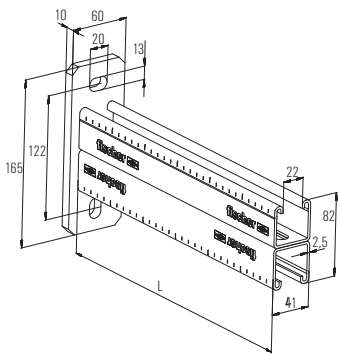

FCA 41D

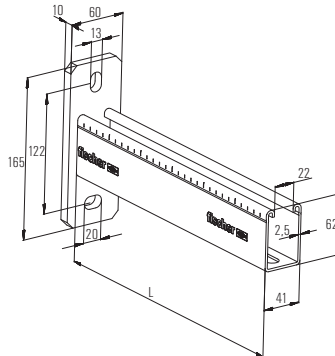

FCA 62

Item	Art.-No.	Fire test report	Profile	Length	Sales unit
				L [mm]	
FCA 21 - 200	537207	—	21/2,0	200	1
FCA 21 - 300	537208	—	21/2,0	300	1
FCA 21 - 450	537209	—	21/2,0	450	1
FCA 41 - 300	077359	X	41/2,5	300	1
FCA 41 - 450	077361	X	41/2,5	450	1
FCA 41 - 600	077363	X	41/2,5	600	1
FCA 41 - 750	077365	X	41/2,5	750	1
FCA 62 - 1000	504315	X	62/2,5	1000	1
FCA 21D - 300	536978	—	21D/2,0	300	1
FCA 21D - 450	536979	—	21D/2,0	450	1
FCA 21D - 600	536980	—	21D/2,0	600	1
FCA 41D - 750	504317	—	41D/2,5	750	1
FCA 41D - 1000	504319	—	41D/2,5	1000	1

LOADS

Item	Art.-No.	Max. recommended static load load case 1	Max. recommended static load load case 2	Max. recommended static load load case 3
		F _{rec} [kN]	F _{rec} [kN]	F _{rec} [kN]
FCA 21 - 200	537207	1.43	0.72	1.43
FCA 21 - 300	537208	0.95	0.45	0.95
FCA 21 - 450	537209	0.65	0.21	0.65
FCA 41 - 300	077359	1.8	0.9	1.8
FCA 41 - 450	077361	1.2	0.6	1.2
FCA 41 - 600	077363	0.9	0.45	0.9
FCA 41 - 750	077365	0.72	0.36	0.72
FCA 62 - 1000	504315	1.25	0.62	1.25
FCA 21D - 300	536978	1.83	0.92	1.83
FCA 21D - 450	536979	1.24	0.62	1.24
FCA 21D - 600	536980	0.92	0.46	0.92
FCA 41D - 750	504317	2.5	1.25	2.5
FCA 41D - 1000	504319	1.9	0.93	1.9

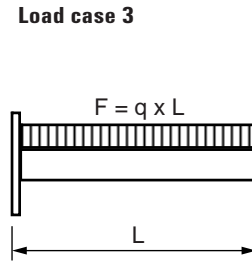
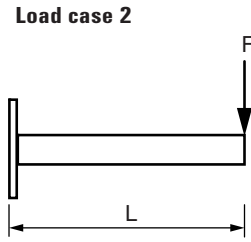
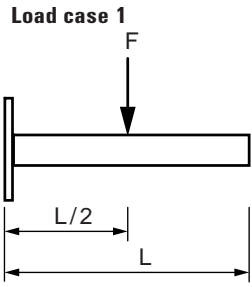

FCA 21

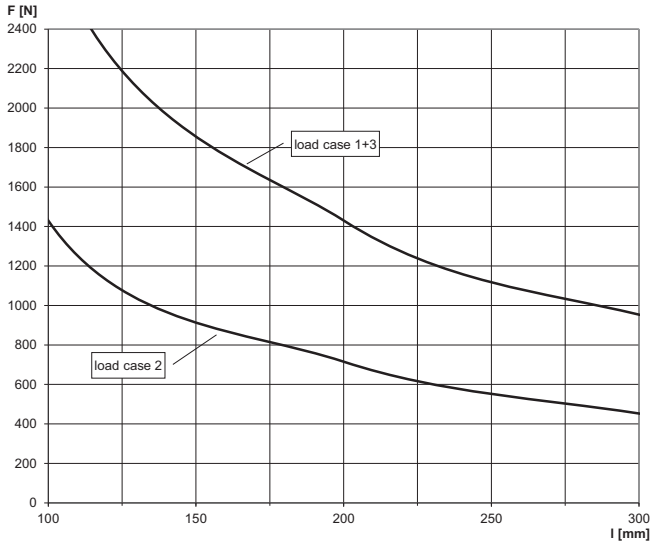

FCA 41

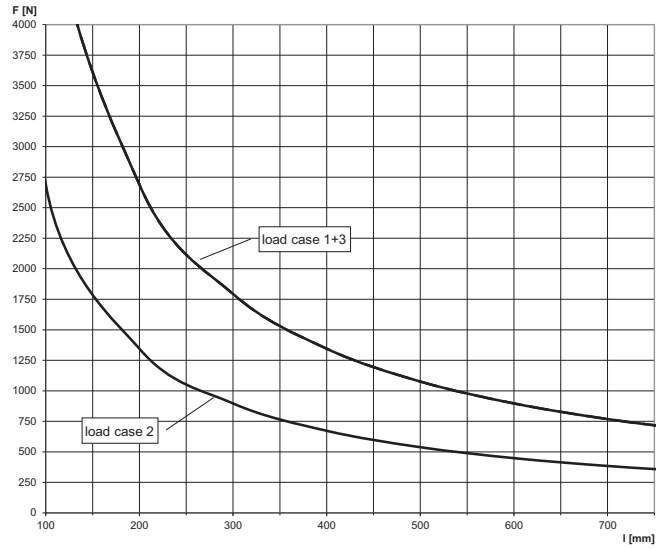

For the load curves, the permissible steel strain $\delta_{adm.} = 160$ N/mm and the maximum deflection under load $L/150$ are not exceeded. Load values of the cantilever arms under consideration of the load capacity of the base plate. Fixings and screw fastenings must be calculated accordingly.

FCA 62

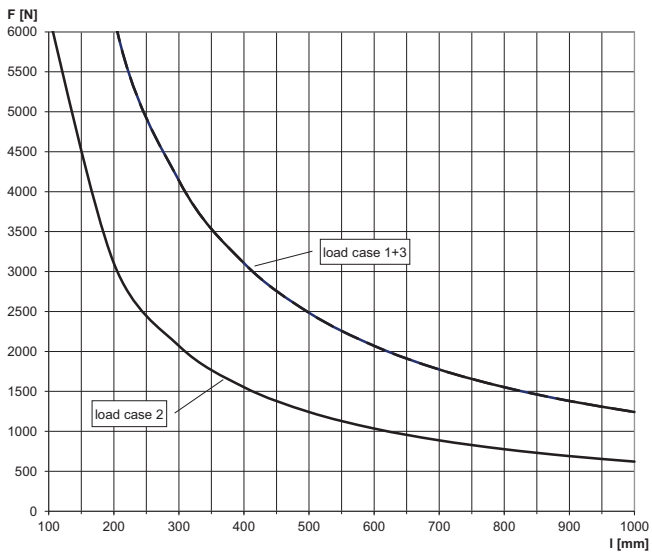

For the load curves, the permissible steel strain $\delta_{adm.} = 160$ N/mm and the maximum deflection under load $L/150$ are not exceeded. Load values of the cantilever arms under consideration of the load capacity of the base plate. Fixings and screw fastenings must be calculated accordingly.

FCA 21D

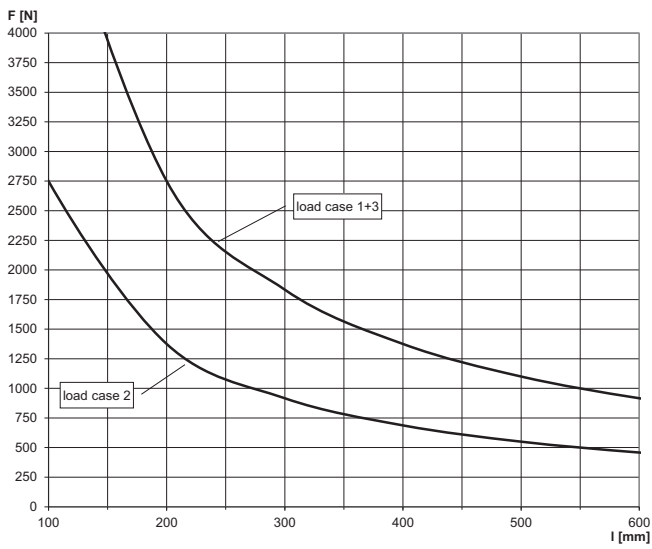

FCA 41D

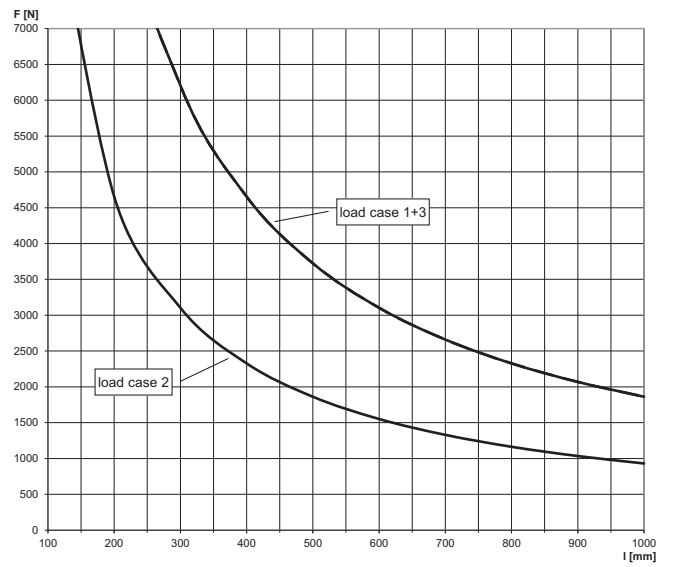

For the load curves, the permissible steel strain $\delta_{adm.} = 160 \text{ N/mm}$ and the maximum deflection under load $L/150$ are not exceeded. Load values of the cantilever arms under consideration of the load capacity of the base plate. Fixings and screw fastenings must be calculated accordingly.

The large cantilever arm for heavy loads

Installation system FUS 4



Upright pipe on cantilever arm



Sliding element on cantilever

APPLICATIONS

- Quick and easy installation of pipelines with heavy loads, (e.g. along the wall)

ADVANTAGES/BENEFITS

- The robust construction, consisting of a basic and a support profile, allows for the bearing of heavy loads.
- The graduated range of lengths allows for an ideal adaptation to the application.
- The base plate's long slots, which are at 90° to one another, allow the arm to be easily aligned.
- The stamped teeth in the channel gives the sliding nuts a secure hold for high shear loads, e.g. for vertical installation.

PROPERTIES

- **Material:** steel S235 JR (material no.10037) acc. to DIN EN 10025
- **Zinc plating:** electro zinc-plated, min. 10 µm

TECHNICAL DATA

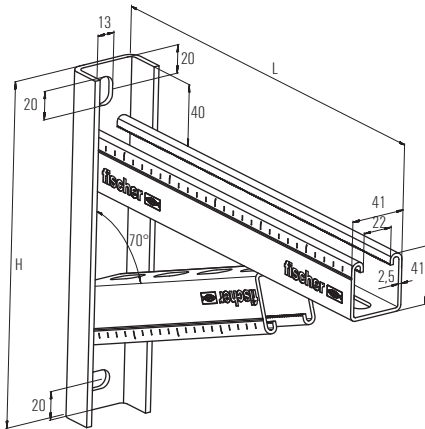

Item	Art.-No.	Length	Height H	Sales unit	
		L1 [mm]	H [mm]	[pcs]	
FCAM 300	504477	300	246	1	
FCAM 400	504479	400	270	1	
FCAM 500	504480	500	284	1	
FCAM 600	504482	600	319	1	
FCAM 700	505460	700	343	1	

LOADS

Item	Art.-No.	Max. recommended static load load case 1 F_{rec} [kN]	Max. recommended static load load case 2 F_{rec} [kN]	Max. recommended static load load case 3 F_{rec} [kN]
FCAM 300	504477	7.0	3.7	7.0
FCAM 400	504479	7.5	2.8	7.5
FCAM 500	504480	6.5	2.3	6.5
FCAM 600	504482	6.0	1.9	6.0
FCAM 700	505460	5.5	1.3	5.5

Load case 1

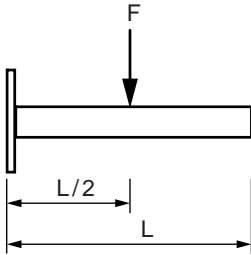

Load case 2

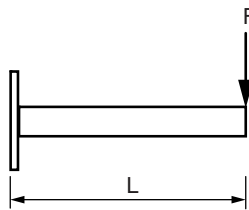

Load case 3

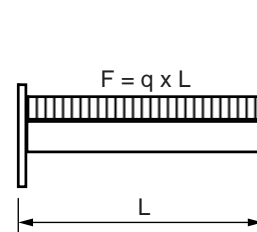

COVER CAP FEC



FEC 21 B

FEC 41 B

FEC 62 B

Item	Art.-No.	For profile	Material	Sales unit [pcs]
FEC 21 B	077357	41/21	polyethylene, black	100
FEC 41 B	077355	41/41	polyethylene, black	100
FEC 62 B	505551	41/62	polyethylene, black	100

Push-through connector for the quickest and easiest connection of FUS profiles



Cross connection on channel



Cantilever with saddle flange

APPLICATIONS

- Connection of FUS channels and construction elements by push-through principle
- Universal fitting for all push-through connection elements and FUS profiles

ADVANTAGES/BENEFITS

- The correct fit of the push-through connector and connection elements allows the quickest and easiest channel connection.
- The spring effect of the PFCN in set state guarantees a simple and precise positioning in the channel.
- The teeth on the push through connector provide a secure hold in the FUS channel.
- Installation by rotating 90° enables generally the post-installation in set channels.

PROPERTIES

- **Material Cap:** steel DD11 (material no. 1.0332) acc. to DIN EN 10111
- **Material Sliding nut:** steel S420MC, EN 10149-2
- **Material Hexagon screw:** 8.8 M10-28, DIN 933
- **Material Plastic parts:** polypropylene
- **Zinc plating:** electro zinc-plated acc. to DIN 50979, min. 8 µm

TECHNICAL DATA

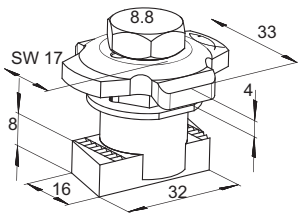

Item	Art.-No.	Thread	Sales unit		
PFCN 41	533739	A M 10	[pcs] 50		



LOADS

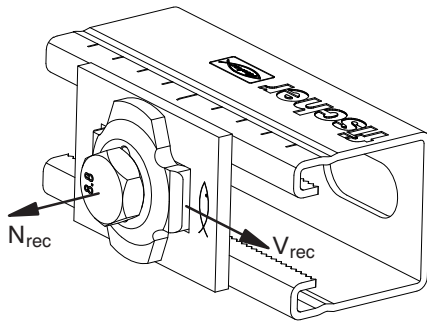

Item	Art.-No.	Max. recommended tension load for FUS 2,0mm N_{rec} [kN]	Max. recommended tension load for FUS 2,5mm N_{rec} [kN]	Max. recommended shear load V_{rec} [kN]	Tightening torque for screw grade ≥ 8.8 T_{inst} [Nm]
PFCN 41	533739	5.0	7.0	3.5	40

Note: Load values are based on the PFCN 41 push-through connector.

Construction element - Saddle flange PSF

Installation system FUS

4



Pipe installation in escape route



Cantilever with saddle flange

APPLICATIONS

- Stable construction of connections between channels and building structures for the push-through system

ADVANTAGES/BENEFITS

- The perfect-fit saddle allows a simple installation by inserting the mounting channels
- The saddle flange's stable design offers a secure hold for a load-bearing construction

PROPERTIES

- **Material:** steel DD11 (material no. 1.0332) acc. to DIN EN 10111
- **Zinc plating:** electro zinc-plated acc. to DIN 50979, min. 8 µm

TECHNICAL DATA

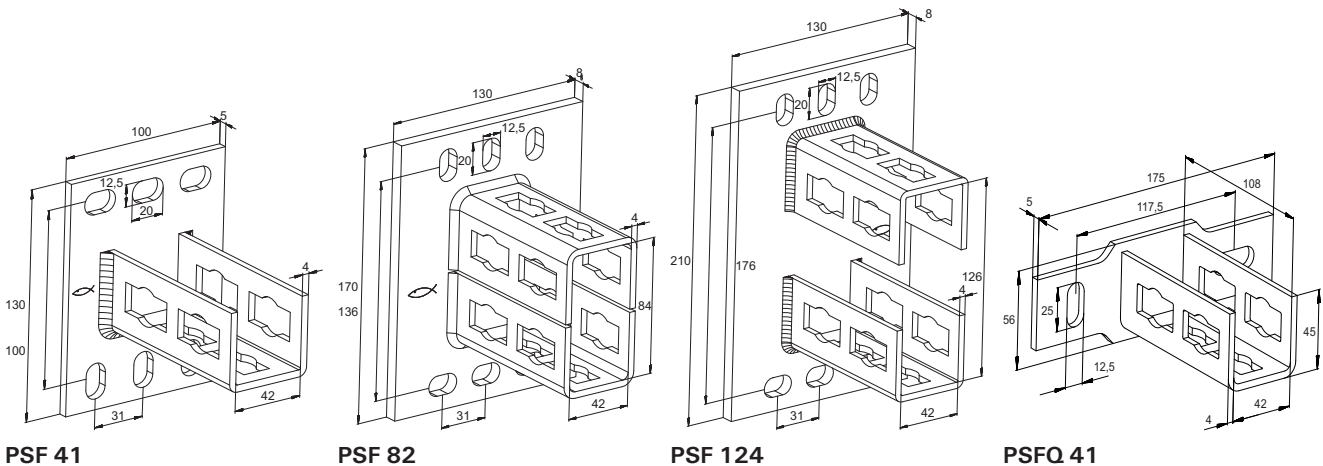

Item	Art.-No.	For profile	Sales unit [pcs]		
PSF 41	533740	21D, 41, 62	10		
PSF 82	533741	41 D	5		
PSF 124	533742	62 D	5		
PSFQ 41	535266	41	10		

LOADS

see Push-through connector PFCN

Construction element - Universal bracket PUWS



APPLICATIONS

- Reinforcement of supporting structures for the push-through system

ADVANTAGES/BENEFITS

- The universal brackets for the connection of FUS channels gives a supporting structure, great stability and safety (we recommend using in pairs).

PROPERTIES

- Material:** steel DD11 (material no. 1.0332) acc. to DIN EN 10111
- Zinc plating:** electro zinc-plated acc. to DIN 50979, min. 8 µm

TECHNICAL DATA

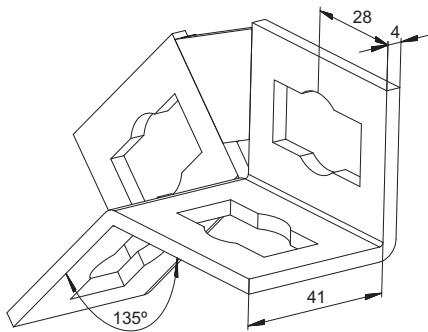

PUWS 2 x 2/135°

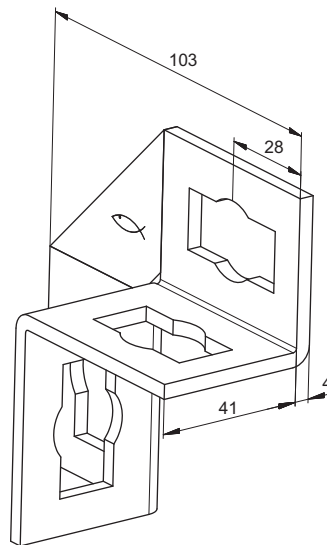

PUWS 2 x 2

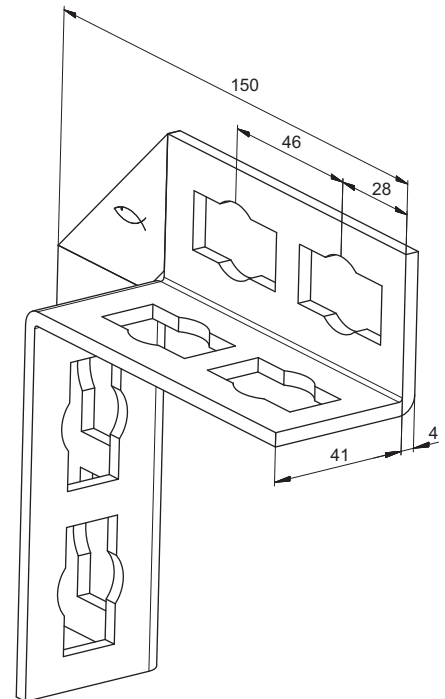

PUWS 4 x 4

Item	Art.-No.	Sales unit [pcs]			
PUWS 2 x 2/135°	533731	10			
PUWS 2 x 2	533733	10			
PUWS 4 x 4	533734	8			

LOADS

see Push-through connector PFCN

Construction element - Angle bracket PWK

Installation system FUS 4

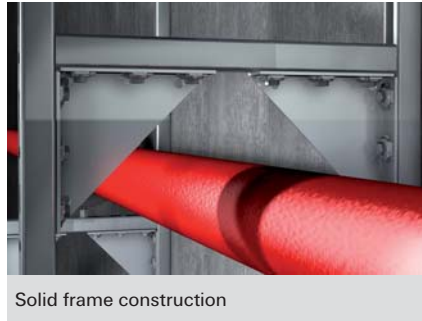

APPLICATIONS

- Reinforcement in the push-through system and for lateral fixing to the substrate

ADVANTAGES/BENEFITS

- The stable angle bracket ensures a supporting structure with a very high level of stability and safety.

PROPERTIES

- Material:** steel DD11 (material no. 1.0332) acc. to DIN EN 10111
- Zinc plating:** electro zinc-plated acc. to DIN 50979, min. 8 µm

TECHNICAL DATA

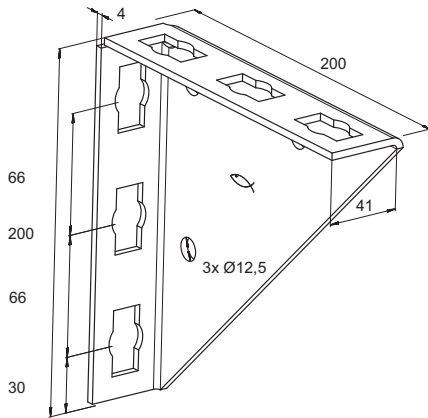

PWK 200/200

Item	Art.-No.	Sales unit [pcs]			
PWK 200/200	533744	15			

LOADS

see Push-through connector PFCN

Construction element – Variable bracket PVB

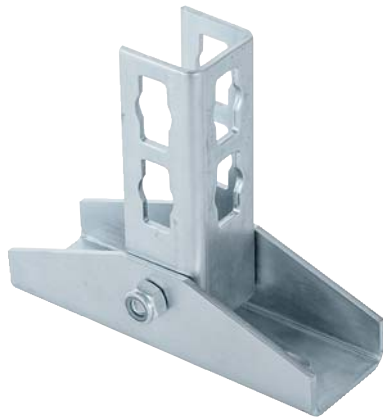

Massiv bracing of cantilever arm

APPLICATIONS

- Variable angular positioning of profile support in the push-through system
- Bracket for installation with FUS channels from 0° to 180°

ADVANTAGES/BENEFITS

- The design of the variable bracket PVB enables the fixation of mounting channels at an angle of 0° to 180°.
- The holes in the connecting element make it compatible with the push-through connector PFCN.
- The punched holes in the base plate allow the direct fixing onto a wall, ceiling or onto a mounting channel by screw or anchor.

PROPERTIES

- **Material:** steel DD11 (material no. 1.0332) acc. to DIN EN 10111
- **Zinc plating:** electro zinc-plated acc. to DIN 50979, min. 8 µm

TECHNICAL DATA

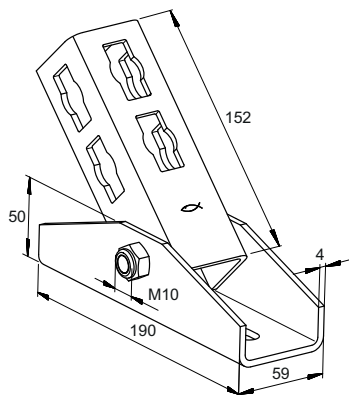

Item	Art.-No.	Sales unit [pcs]			
PVB	534960	5			

LOADS

see Push-through connector PFCN

Construction elements – Bracing elements PSAE 300 and 500

4

Installation system FUS



Supported channel

APPLICATIONS

- Elements for stable cantilever constructions made of FUS channels or FCA cantilever arms with push-through connector PFCN

ADVANTAGES/BENEFITS

- The stable bracing element PSAE gives the supporting structure very high stability and safety.
- The holes in the base plate of the element make it compatible with the push-through connector PFCN.
- An additional PU-washer allows for fixing of elements with formholes directly onto a wall or ceiling by anchor or screw.

PROPERTIES

- **Material:** steel P235TR2 (material no. 1.0255) acc. to EN 10216-1
- **Zinc plating:** electro zinc-plated acc. to DIN 50979, min. 8 µm

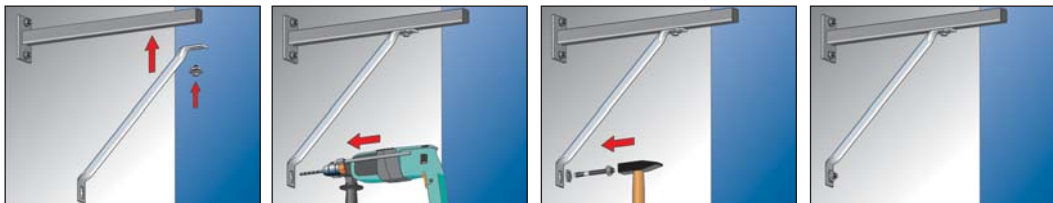

TECHNICAL DATA

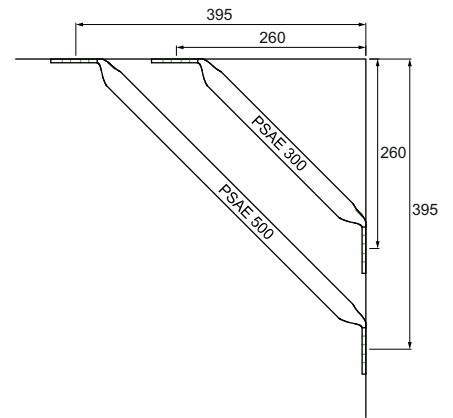
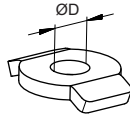
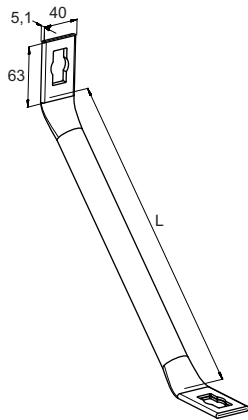

PSAB

PU

Item	Art.-No.	Length	Sales unit		
		L [mm]	[pcs]		
PSAB 300 Brace element	535269	300	10		
PSAB 500 Brace element	535270	500	10		
PU 10,5 Washer	535271	–	50		
PU 12,5 Washer	535272	–	50		

LOADS

see Push-through connector PFCN

Construction elements - Brackets PFFF

Installation system FUS 4



APPLICATIONS

- Arrangement of simple channel constructions in the push-through system

ADVANTAGES/BENEFITS

- The holes in the connecting elements make them compatible with the push-through connector PFCN.

PROPERTIES

- **Material:** steel DD11 (material no. 1.0332) acc. to DIN EN 10111
- **Zinc plating:** electro zinc-plated acc. to DIN 50979, min. 8 µm

TECHNICAL DATA

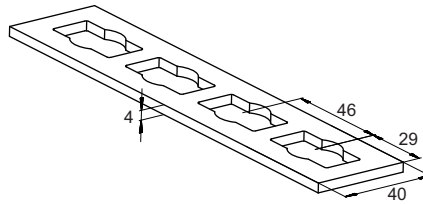
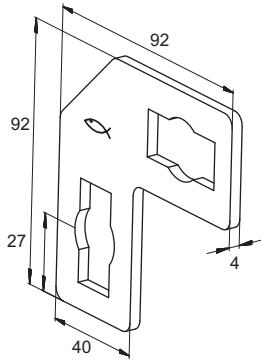

PFFF 2L

PFFF 41

Item	Art.-No.	Sales unit [pcs]			
PFFF 2L	533745	20			
PFFF 41	535268	25			

LOADS

see Push-through connector PFCN

Construction elements - Brackets PFAF



APPLICATIONS

- Arrangement of simple channel constructions in the push-through system

ADVANTAGES/BENEFITS

- The holes in the connecting elements make them compatible with the push-through connector PFCN.

PROPERTIES

- **Material:** steel DD11 (material no. 1.0332) acc. to DIN EN 10111
- **Zinc plating:** electro zinc-plated acc. to DIN 50979, min. 8 µm

TECHNICAL DATA

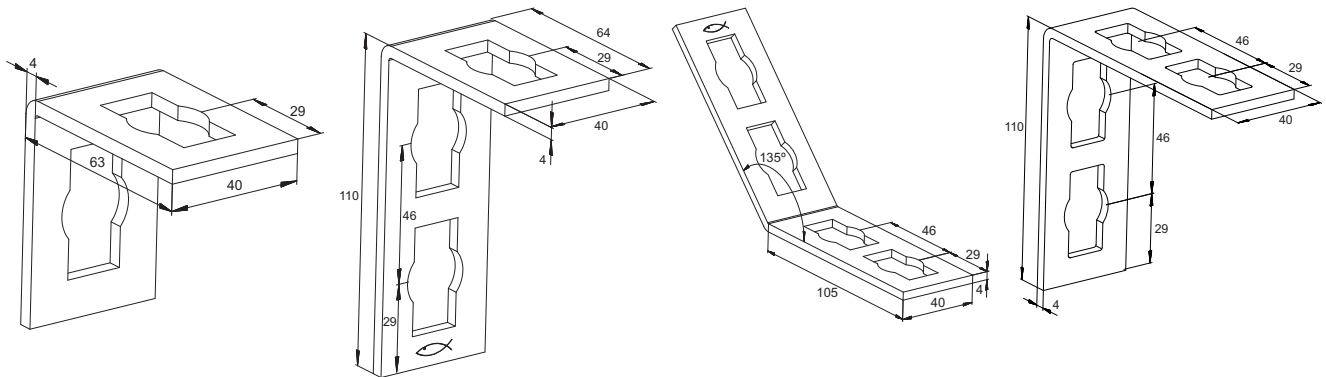

PFAF 2

PFAF 3

PFAF 4/135°

PFAF 4

Item	Art.-No.	Sales unit				
			[pcs]			
PFAF 2	533735		25			
PFAF 3	533736		25			
PFAF 4/135°	533737		20			
PFAF 4	535267		25			

LOADS

see Push-through connector PFCN

Construction elements - Brackets PFUF

Installation system FUS 4



APPLICATIONS

- Connecting elements for multi-dimensional channel constructions

ADVANTAGES/BENEFITS

- The various shapes of the connecting elements offer flexibility during the installation of channel constructions.
- The holes in the connecting elements make them compatible with the push-through channel nut PFCN.

PROPERTIES

- **Material:** steel DD11 (material no. 1.0332) acc. to DIN EN 10111
- **Zinc plating:** electro zinc-plated acc. to DIN 50979, min. 8 µm

TECHNICAL DATA

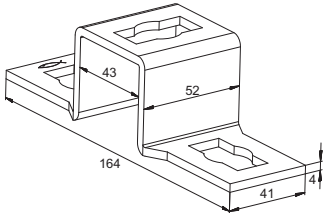

PFUF 41

Item	Art.-No.	Sales unit [pcs]			
PFUF 41	533738	25			

LOADS

see Push-through connector PFCN

Construction elements - Bracket PFUF 3D and 4D

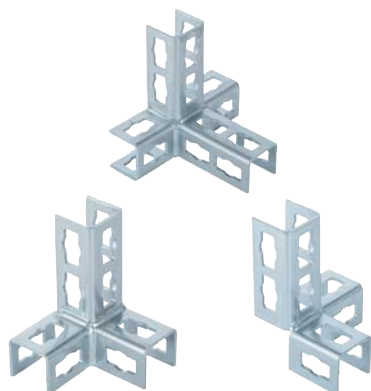

APPLICATIONS

- Element for multidimensional constructions with FUS channels connected by the push-through connector PFCN

ADVANTAGES/BENEFITS

- The 3D PFUF construction elements enable multidimensional constructions in a very short time.
- The holes in the construction elements make them compatible with the push-through connector PFCN.
- The different shapes of the construction elements generate a high flexibility for channel constructions.

PROPERTIES

- **Material:** steel DD11 (material no. 1.0332) acc. to DIN EN 10111
- **Zinc plating:** electro zinc-plated acc. to DIN 50979, min. 8 µm

TECHNICAL DATA

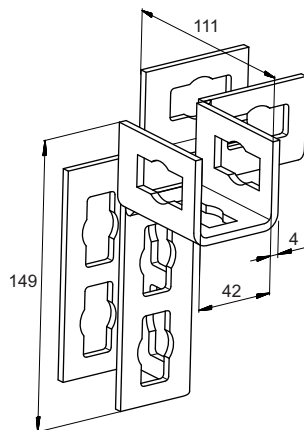

PFUF 3DL

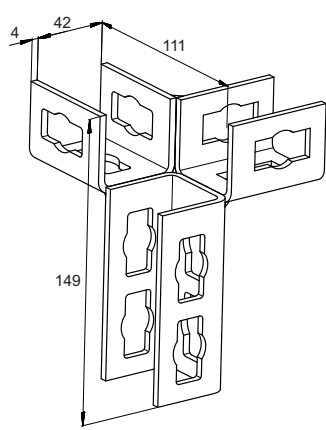

PFUF 3DR

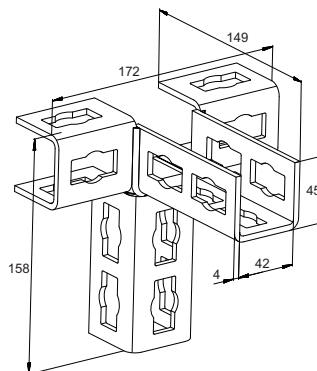

PFUF 4D

Item	Art.-No.	Sales unit			
		[pcs]			
PFUF 3DL	535273	10			
PFUF 3DR	535274	10			
PFUF 4D	535275	10			

LOADS

see Push-through connector PFCN

Channel nut for quick and easy fixing in FUS profiles

Installation system FUS 4



APPLICATIONS

- FCN Clix P: connection of FUS channels and fixtures
- FCN Clix M: connection of pipe clamps to FUS channel under the use of threaded rods

ADVANTAGES/BENEFITS

- The sliding nut design enables a quick and easy setting in the channel.
- The spring effect of the plastic clasp guarantees simple and precise positioning in the channel.
- The FCN Clix P's flat plastic mounting with wings offers a good hold and a convenient mounting.
- The teeth on the sliding nut provide a secure hold in the FUS channel.
- Installation by rotating 90° enables post-installation in installed channel.

CERTIFICATES



PROPERTIES

- **Material:** steel S235 JR (material no. 1.0037) acc. to DIN EN 10025, plastic Nylon PA6
- **Zinc plating:** electro zinc-plated, min. 5 µm



TECHNICAL DATA

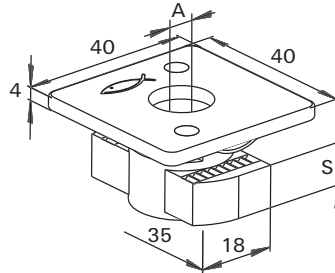
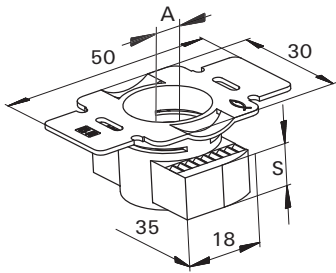

FCN Clix P

FCN Clix M

Item	Art.-No.	Fire test report	Thread	Thickness	Sales unit [pcs]
			A	S [mm]	
FCN Clix P 6	504326	—	M 6	6	100
FCN Clix P 8	504327	—	M 8	6	100
FCN Clix P 10	504329	X	M 10	8	100
FCN Clix P 12	504331	X	M 12	9.5	100
FCN Clix M 6	504344	—	M 6	6	100
FCN Clix M 8	504345	—	M 8	6	100
FCN Clix M 10	504346	X	M 10	8	100
FCN Clix M 12	504347	X	M 12	9.5	100

LOADS

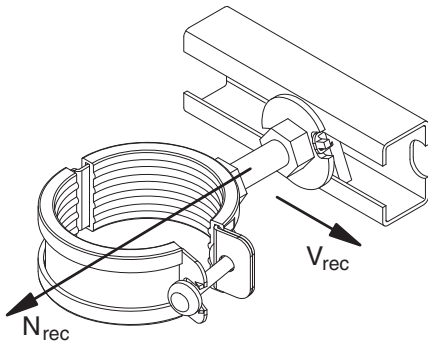

Item	Art.-No.	Max. recommended tension load for FUS 2,0mm	Max. recommended tension load for FUS 2,5mm	Max. recommended shear load	Tightening torque for screw grade ≥ 8.8	Tightening torque for screw grade ≥ 4.6
		N_{rec} [kN]	N_{rec} [kN]	V_{rec} [kN]	T_{inst} [Nm]	T_{inst} [Nm]
FCN Clix P 6	504326	3.0	3.0	1.0	10	—
FCN Clix P 8	504327	4.0	4.0	2.0	20	—
FCN Clix P 10	504329	5.0	8.0	2.5	40	—
FCN Clix P 12	504331	5.0	8.0	3.0	50	—
FCN Clix M 6	504344	3.0	3.0	—	—	5
FCN Clix M 8	504345	4.0	4.0	—	—	10
FCN Clix M 10	504346	5.0	8.0	—	—	15
FCN Clix M 12	504347	5.0	8.0	—	—	20

Hammer-head bolt for quick and easy fixing in FUS profiles



Leightweight installation on cantilever



Bracings with UHRS

4

Installation system FUS

APPLICATIONS

- Connection of pipe clamps to the channel

ADVANTAGES/BENEFITS

- The hammer-head nut design for a quick and easy setting in the channel.
- The spring effect of the plastic bands guarantees simple and precise positioning in the channel.
- Installation by rotating 90° enables post-installation in installed channel.

PROPERTIES

- **Material washer:** steel DC01-C490 (material no.1.0330) acc. to DIN EN 10139
- **Hammer head bolt:** resistance class 8.8
- **Nut DIN 934:** resistance class min. 4
- **Zinc plating:** electro zinc-plated, min. 5 µm

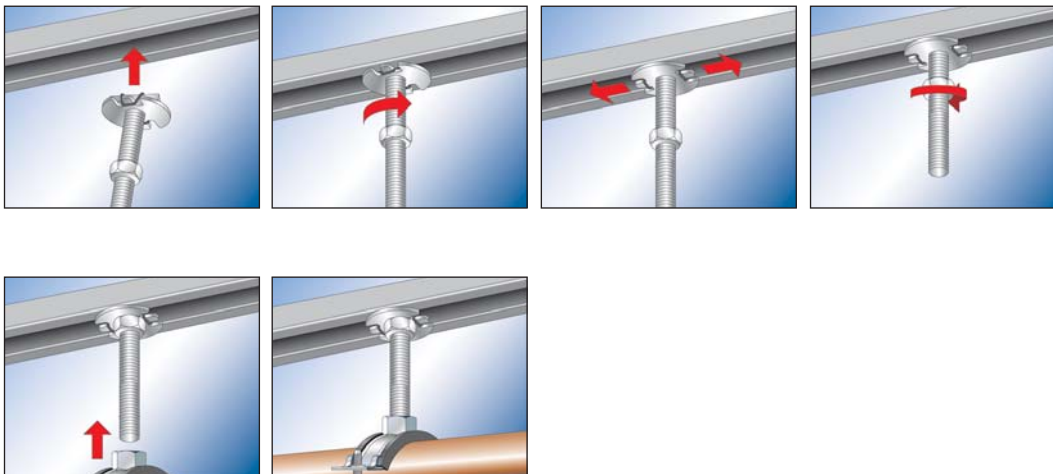

TECHNICAL DATA

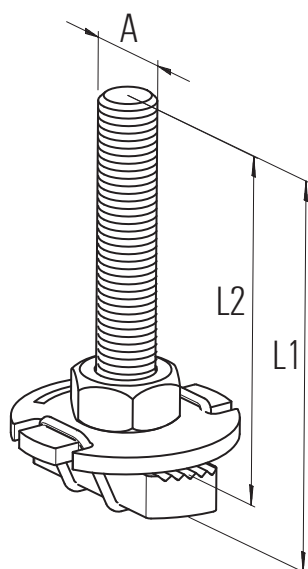

Item	Art.-No.	Thread	Length	Length	Sales unit
		A	L1 [mm]	L2 [mm]	[pcs]
FHS CLIX S 8 x 30	020914	M 8	36	30	50
FHS CLIX S 8 x 40	020915	M 8	46	40	50
FHS CLIX S 8 x 60	020916	M 8	66	60	50
FHS CLIX S 10 x 30	020917	M 10	37	30	50
FHS CLIX S 10 x 40	020918	M 10	47	40	50
FHS CLIX S 10 x 60	020919	M 10	67	60	50
FHS CLIX S 12 x 30	020969	M 12	38	30	50
FHS CLIX S 12 x 40	047316	M 12	48	40	50
FHS CLIX S 12 x 60	504320	M 12	68	60	50

LOADS

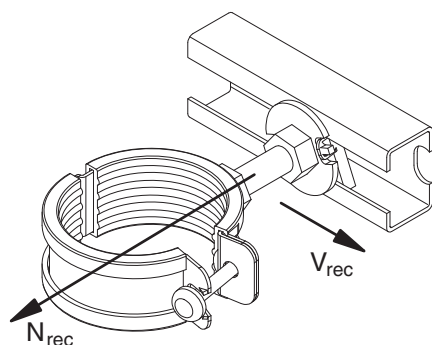

Item	Art.-No.	Max. recommended tension load for FUS	Max. recommended tension load for FUS	Tightening torque
		2,0mm N_{rec} [kN]	2,5mm N_{rec} [kN]	T_{inst} [Nm]
FHS CLIX S 8 x 30	020914	4.0	4.0	5
FHS CLIX S 8 x 40	020915	4.0	4.0	5
FHS CLIX S 8 x 60	020916	4.0	4.0	5
FHS CLIX S 10 x 30	020917	4.0	5.0	10
FHS CLIX S 10 x 40	020918	4.0	5.0	10
FHS CLIX S 10 x 60	020919	4.0	5.0	10
FHS CLIX S 12 x 30	020969	4.0	5.0	10
FHS CLIX S 12 x 40	047316	4.0	5.0	10
FHS CLIX S 12 x 60	504320	4.0	5.0	10

Connector - Channel nut FCN



4

Installation system FUS

APPLICATIONS

- Simple hammer-head nut for installation in FUS channels
- The FCN is suitable for the connection of different fixtures and pipe clamps with the channel

ADVANTAGES/BENEFITS

- The teeth on the sliding nut provide a secure hold in the FUS channel.

PROPERTIES

- **Material:** steel with min. tensile strength of 415 N/mm²
- **Zinc plating:** electro zinc-plated, min. 5 µm

TECHNICAL DATA

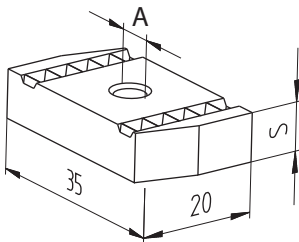

Item	Art.-No.	Thread	Thickness	Sales unit
		A	S [mm]	[pcs]
FCN 6	077405	M 6	6	100
FCN 8	077407	M 8	6	100
FCN 10	077409	M 10	8	100
FCN 12	077411	M 12	9	100

LOADS

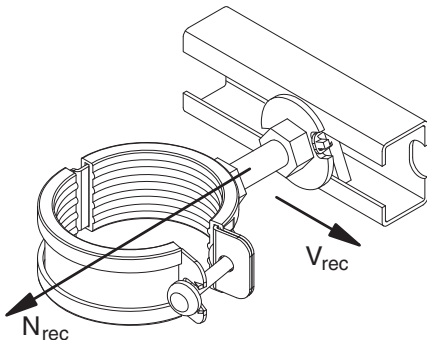

Item	Art.-No.	Max. recommended tension load for FUS 2,0mm	Max. recommended tension load for FUS 2,5mm	Max. recommended shear load	Tightening torque for screw grade ≥ 8.8
		N _{rec} [kN]	N _{rec} [kN]	V _{rec} [kN]	T _{inst} [Nm]
FCN 6	077405	3.0	3.0	1.0	10
FCN 8	077407	4.0	4.0	2.0	20
FCN 10	077409	5.0	8.0	2.5	40
FCN 12	077411	5.0	8.0	2.5	50

Connector - Channel washer HK



Lateral pipe mounting at channel



Channel installation at wall

APPLICATIONS

- Channel washer to strengthen the profile

ADVANTAGES/BENEFITS

- The U-shape of the channel washer prevents the profile from bending effectively.
- The shape of the channel washer makes the push-through installations of channel profiles quick and easy.

CERTIFICATES



PROPERTIES

- Material:** steel S235 JR (material no.: 1.0037) acc. to DIN EN 10025
- Zinc plating:** electro zinc-plated, min. 5 µm

TECHNICAL DATA

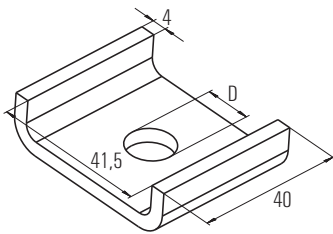

Item	Art.-No.	Fire test report	Hole diameter	Sales unit	
			A [mm]	[pcs]	
HK 41 8,5	504348	—	8,5	50	
HK 41 10,5	504349	X	10,5	50	
HK 41 12,5	504354	X	12,5	50	

SEE ALSO



SKS
see page 201



U
see page 201



MU
see page 202

Construction element - Saddle flange SF

Installation system FUS 4

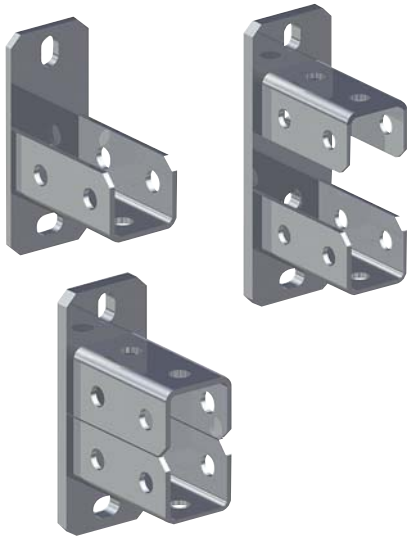

CERTIFICATES



APPLICATIONS

- For solid connections between the channel and building structures

ADVANTAGES/BENEFITS

- The perfect-fit saddle of the SF enables a simple installation by inserting the channel.
- The saddle flange's stable design offers a secure hold for a load-bearing construction.

PROPERTIES

- Material base plate:** steel DC01 (material no. 1.0330) acc. to DIN EN 10139
- Zinc plating base plate:** electro zinc-plated, min. 8 μ m
- Material U-Profile:** steel S235 JR (material no. 1.0037) nach DIN EN 10025
- Zinc plating U-Profile:** electro zinc-plated, min. 8 μ m

TECHNICAL DATA

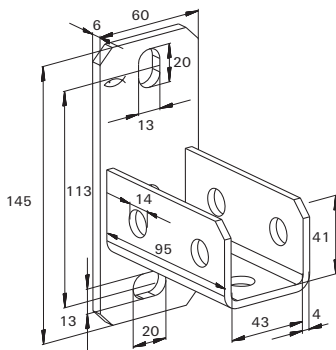

SF L 41

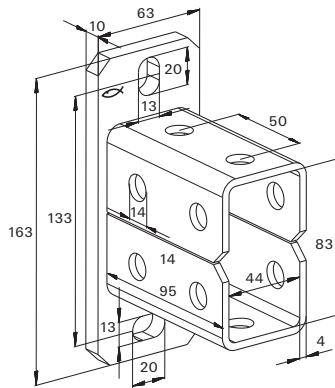

SF L 82

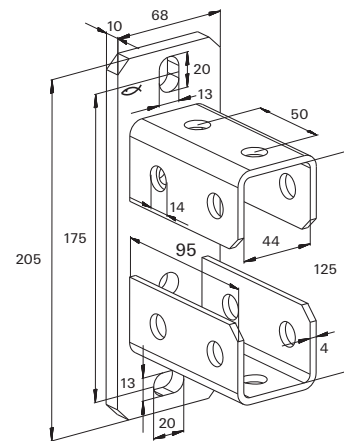

SF L 124

Item		Fire test report	For profile	Sales unit	
				[pcs]	
SF L 41	504355	X	21, 41, 21D, 62	10	
SF L 82	504357	—	41 D	5	
SF L 124	504358	—	62 D	5	

Construction element - Universal bracket UWS



3D-frame constructions



Support systems for ventilation

APPLICATIONS

- Universal angle bracket for the reinforcement of supporting structures

ADVANTAGES/BENEFITS

- The universal bracket for the connection of fischer channels gives a supporting structure, great stability and safety (we recommend using in pairs).

CERTIFICATES



PROPERTIES

- **Material:** steel S235 JR (material no.: 1.0037) acc. to DIN EN 10025
- **Zinc plating:** electro zinc-plated, min. 5 µm

TECHNICAL DATA

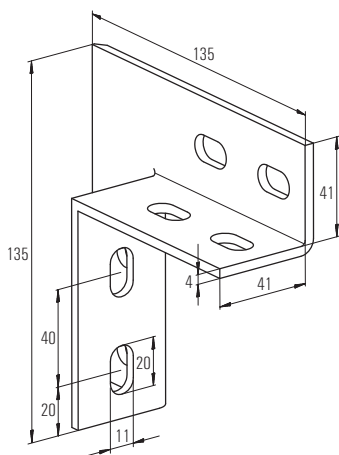

Item	Art.-No.	Fire test report	Sales unit		
			[pcs]		
UWS	049479	X	10		

Construction element - Angle bracket WK

Installation system FUS 4



Heavy drainage pipe under angle bracket



Solid frame construction

APPLICATIONS

- Reinforcement and fixing of pipelines and pipe components

ADVANTAGES/BENEFITS

- The design of the angle bracket allows for the fixing of pipe clamps or channels.
- The stable angle ensures a very high level of stability and safety to the structure.

PROPERTIES

- Material:** steel DD11 (material no. 1.0332) acc. to DIN EN 10111
- Zinc plating:** electro zinc-plated, min. 8 µm

TECHNICAL DATA

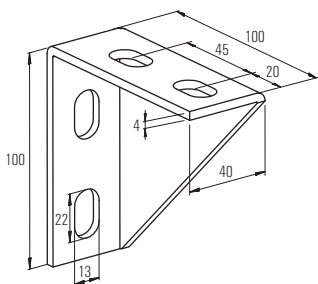

WK 100/100

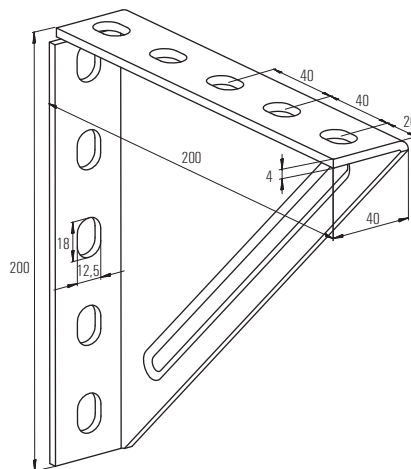

WK 200/200

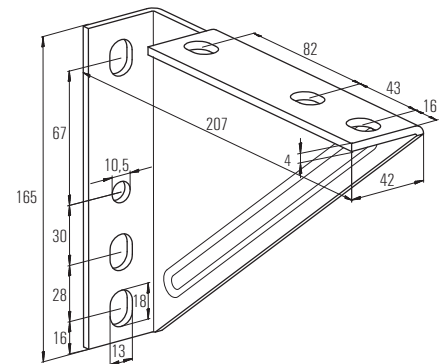

WK 207/165

Item	Art.-No.	Sales unit			
			[pcs]		
WK 100/100	063559		5		
WK 200/200	079570		5		
WK 207/165	079571		6		

LOADS

Item	Art.-No.	Max. recommended static load load case 1	Max. recommended static load load case 2
		F_{rec} [kN]	F_{rec} [kN]
WK 100/100	063559	–	4.0
WK 200/200	079570	4.0	1.8
WK 207/165	079571	–	1.8

Load case 1

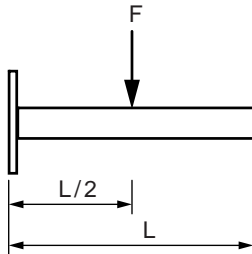

Load case 2

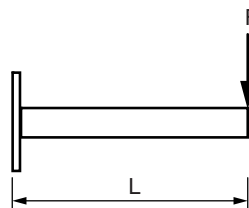

Construction element - Universal mounting UHRS



Channel bracing for installation grid



Bracings with UHRS

4

Installation system FUS

APPLICATIONS

- Variable anchor bracket for anchoring with threaded rods
- Can be used together with FHS Clix S M 12

ADVANTAGES/BENEFITS

- The design of the universal mount allows the anchoring by using threaded rods at all angles.
- The hole in the base plate enables the direct fixing onto a wall or ceiling, or onto a channels.

PROPERTIES

- **Material:** steel S235 JRG (material no. 1.0038) acc. to DIN EN 10025
- **Zinc plating:** electro zinc-plated, min. 3 µm

TECHNICAL DATA

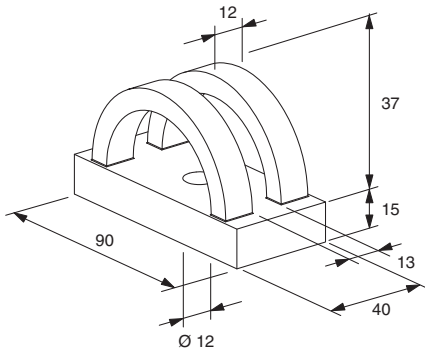

Item	Art.-No.	Sales unit [pcs]			
UHRS	063938	6			

LOADS

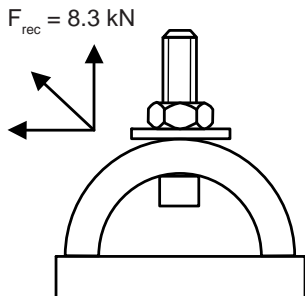

Construction element - Variable bracket VB



APPLICATIONS

- Variable angular positioning of profile supporting structures
- Installation with FUS channels (from 45° to 90°)

ADVANTAGES/BENEFITS

- The design of the channel base VB allows for the fixing of mounting channels at any angle between 45° - 90°.
- The holes in the base plate enable the direct fixing onto a wall or ceiling or onto a channel.

PROPERTIES

- **Material:** steel DD11 (material no. 1.0332) acc. to DIN EN 10111
- **Zinc plating:** electro zinc-plated, min. 5 µm

TECHNICAL DATA

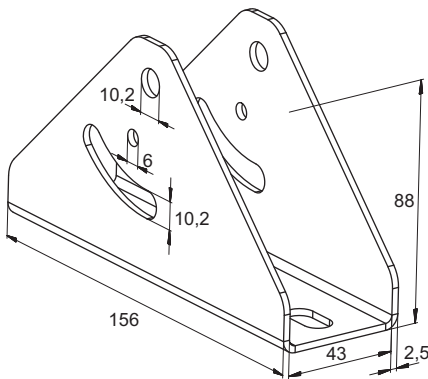

Item	Art.-No.	Slot L x s [mm]	Sales unit [pcs]		
VB	004850	13 x 20	4		

LOADS

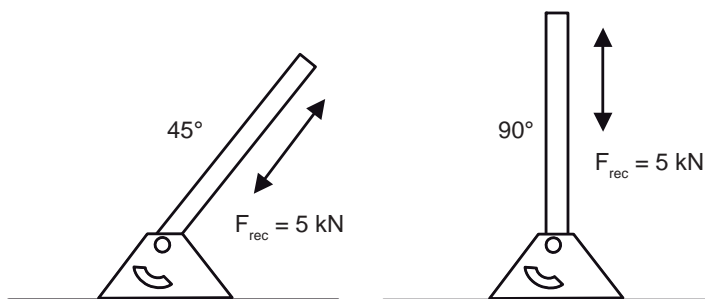

Construction element - Threaded rod bracket FSB 45°



Heavy pipe on cantilever



Bracing for fixpoint

APPLICATIONS

- 45° element for anchoring with M10 threaded rods

ADVANTAGES/BENEFITS

- The anchoring element's socket allows the fast insertion of a pre-mounted M10 threaded rod with nut.
- The hole in the base plate enables the direct fixing onto a wall or ceiling or onto a channel.

PROPERTIES

- **Material:** steel DD11 (material no. 1.0332) acc. to DIN EN 10111
- **Zinc plating:** electro zinc-plated, min. 5 µm

TECHNICAL DATA

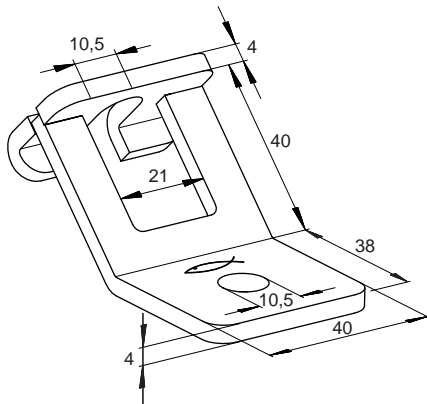

Item	Art.-No.	Sales unit			
		[pcs]			
FSB 45°	071269	20			

LOADS

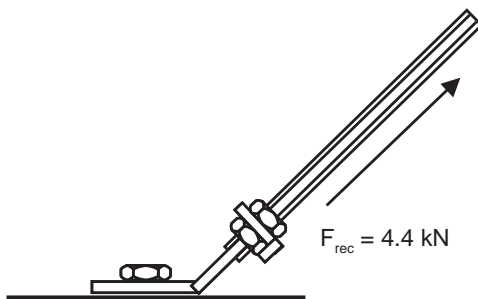

Clamp for fixing of profiles to steel girders



Channel to steelbeam

APPLICATIONS

- Fixing to steel girders requires two clamps per connection

ADVANTAGES/BENEFITS

- The design of the beam clamp allows fixing without drilling or welding.
- The various lengths of the beam clamp enable the fixing on most standard beams.
- The shape of the beam clamp allows the simple adjustment of the channel connection.

PROPERTIES

- Material plate/U-bolt pipe hanger:** steel S235 JR (material no.10037) acc. to DIN EN 10025
- Material hexagon nut:** steel resistance class 8
- Zinc plating:** electro zinc-plated, min. 5 µm

TECHNICAL DATA

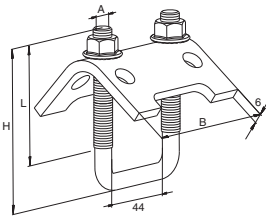

Item	Art.-No.	For profile	Thread	Width B	Height H	Length	Sales unit
			A	B [mm]	H [mm]	L [mm]	[pcs]
TKR 21 - 42	504363	38/40, 21, 41	M 8	79	97	50	20
TKR 82	504366	40/60, 62, 41D	M 10	79	137	80	20
TKR 124	504367	62 D	M 10	79	179	80	10

LOADS

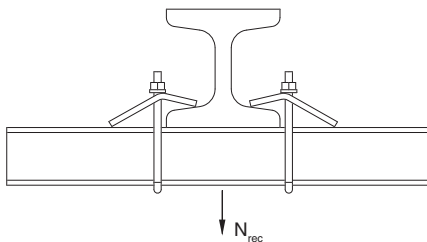

Item	Art.-No.	Max. recom. static load (centr. tension)	Tightening torque
		$N_{\text{recom.}}$ [kN]	T_{inst} [Nm]
TKR 21 - 42	504363	5.00	15
TKR 82	504366	10.00	20
TKR 124	504367	10.00	20

Construction elements - Brackets FFF

Installation system FUS 4



APPLICATIONS

- Connecting elements for the joining or strengthening of simple channel constructions

PROPERTIES

- **Material:** steel S235 JR (material no. 10037) acc. to DIN EN 10025
- **Zinc plating:** electro zinc-plated, min. 5 µm

TECHNICAL DATA

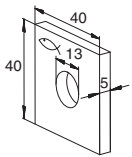

FFF 1

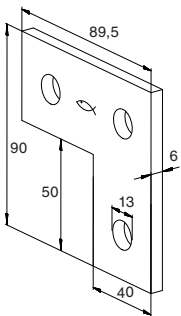

FFF 3L

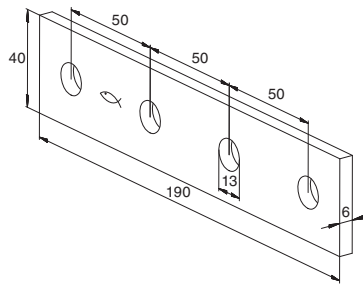

FFF 4

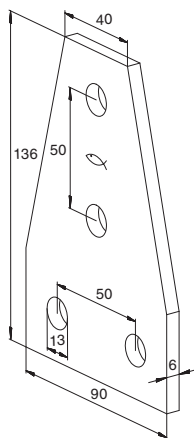

FFF 4D

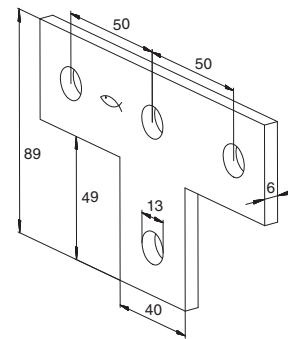

FFF 4T

Item	Art.-No.	Sales unit			
		[pcs]			
FFF 1	504494	25			
FFF 3L	504498	25			
FFF 4	504499	25			
FFF 4T	504500	25			
FFF 4D	504368	25			

LOADS

see Channel nut FCN Clix P

Construction elements - Mounting bracket FAF



APPLICATIONS

- Connecting elements for the joining or strengthening of simple channel constructions

PROPERTIES

- Material:** steel S235 JR (material no. 10037) acc. to DIN EN 10025
- Zinc plating:** electro zinc-plated, min. 5 µm

TECHNICAL DATA

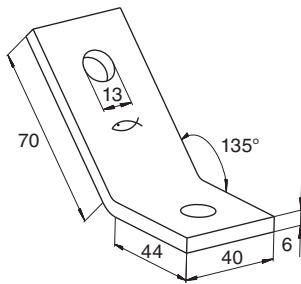

FAF 2/135°

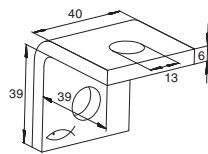

FAF 2

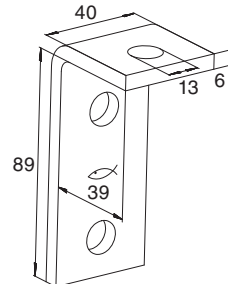

FAF 3

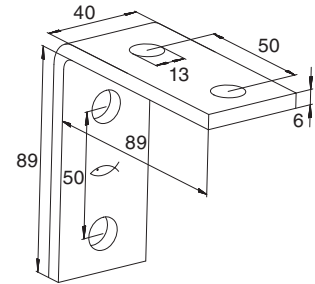

FAF 4

Item	Art.-No.	Sales unit			
			[pcs]		
FAF 2/135° hdg.	537579		25		
FAF 2 hdg.	537576		25		
FAF 3 hdg.	537577		25		
FAF 4 hdg.	537578		25		

LOADS

see Channel nut FCN Clix P

Construction elements - Mounting brackets FZF, FUF

Installation system FUS 4

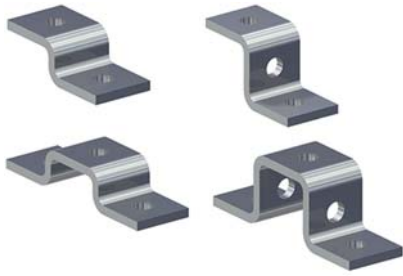

APPLICATIONS

- Connecting elements for multi-dimensional channel constructions

ADVANTAGES/BENEFITS

- The various shapes of the connecting elements offer flexibility during the installation of channel constructions.
- The holes in the connecting elements make them compatible with the FCN Clix P.

PROPERTIES

- **Material:** steel S235 JR (material no. 10037) acc. to DIN EN 10025
- **Zinc plating:** electro zinc-plated, min. 5 µm

TECHNICAL DATA

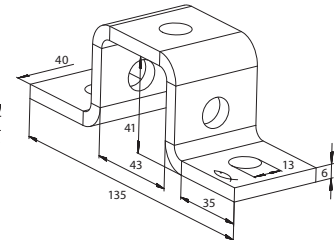
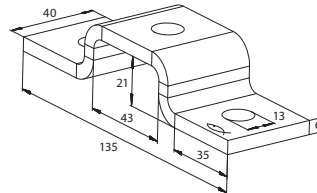
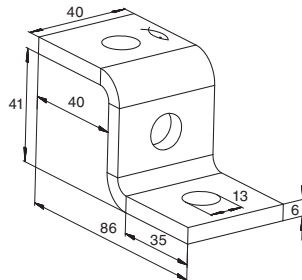
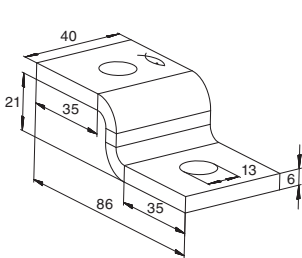

FZF 21

FZF 41

FUF 21

FUF 41

Item	Art.-No.	Sales unit [pcs]			
FZF 21	504375	25			
FZF 41	504515	25			
FUF 21	504376	25			
FUF 41	504377	25			

LOADS

see Channel nut FCN Clix P

Construction elements - Mounting brackets FUF



APPLICATIONS

- Connecting elements for multi-dimensional channel constructions

ADVANTAGES/BENEFITS

- The various shapes of the connecting elements offer flexibility during the installation of channel constructions.
- The holes in the connecting elements make them compatible with the FCN Clix P.

PROPERTIES

- **Material:** steel S235 JR (material no. 10037) acc. to DIN EN 10025
- **Zinc plating:** electro zinc-plated, min. 5 µm

TECHNICAL DATA

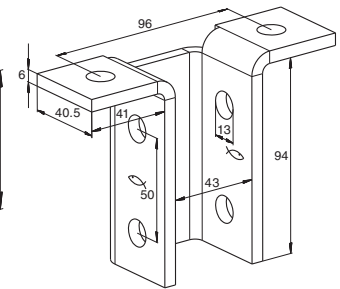
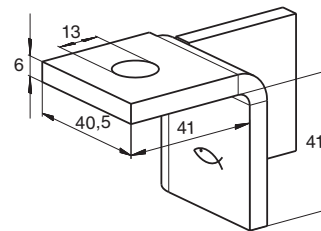
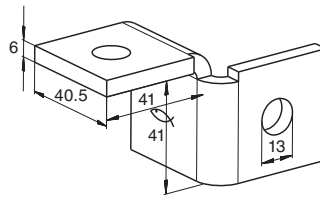
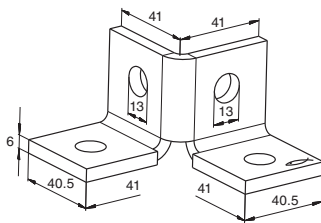

FUF 4Y

FUF 180°L

FUF 180°R

FUF 8T

Item	Art.-No.	Sales unit			
			[pcs]		
FUF 4Y	504378		20		
FUF 180°L	504379		20		
FUF 180°R	504383		20		
FUF 8T	504387		10		









LOADS

see Channel nut FCN Clix P

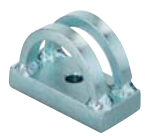

5

Installation Grid

	page		page
Channels		Construction elements	
Channel FUS	 161	Channel connector FUF OC	 161
Connectors		Beam clamp TKR	 163
Cross connector FVS	 160		
Connector FCN Clix P	 165		
Universal mounting UHRS	 165		
T-head bolt FHS Clix S	 164		
Hexagonal connector VM	 163		
Turnbuckle SPS, Bolt left-hand/right-hand BLR	 163		

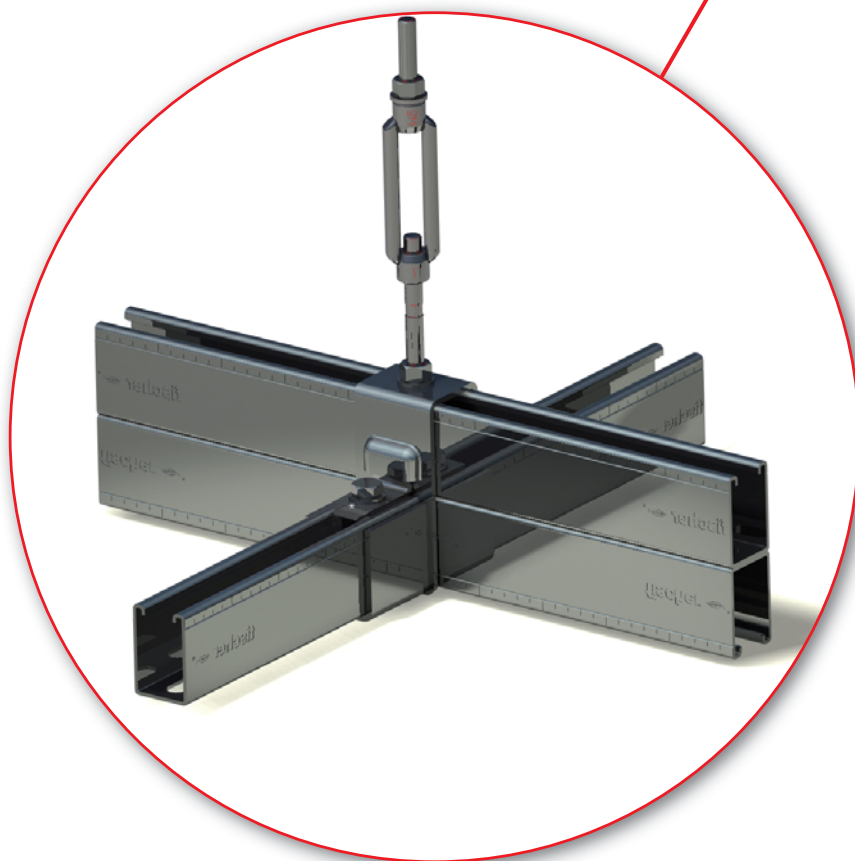

FIT FOR TODAY'S AND TOMORROW'S DEMANDS

Planning for the future means constantly being prepared to meet new requirements. That is why the fischer Installation Grid is the installation system for modern and future supply technology in industrial buildings. Its strengths are:

- quick installation and consequent low costs
- high flexibility and adaptability to change utilization of buildings
- good order and organization in media supply
- new design perspectives
- clear calculation of time and cost thanks to modular construction
- highly economical over the entire duration of utilization
- support in planning and installation provided by fischer engineers

Backed up by the entire know-how and experience of a leading manufacturer of fixing systems.

EFFECTIVE INSTALLATION WITH THE FISCHER INSTALLATION GRID



A separate level for the installation of media-supply equipment is constructed under the ceiling using a system of rails and special fixing elements from the fischer SaMontec program. This Installation Grid can be specially adapted for any building.

Cross connector to increase the flexibility of an installation grid

5



Sliding element on installation grid

APPLICATIONS

- Creation of a grid from a FUS 62D channel as a horizontal channel and a FUS 62 channel as a vertical channel
- Ceiling suspension with the use of threaded rods

ADVANTAGES/BENEFITS

- The design of the cross connector allows for the simple and time-saving creation of an installation grid.
- The cross connector over the vertical channel allows the installation to be carried out by one person.
- The design of the FVS 3 ensures a stable installation.

PROPERTIES

- **Material:** steel S235 JR (material no.: 1.0037) acc. to DIN EN 10025
- **Zinc plating:** electro zinc-plated, min. 5 µm

TECHNICAL DATA

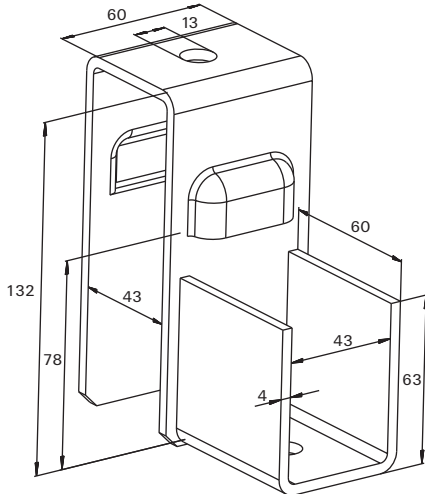

FVS 3

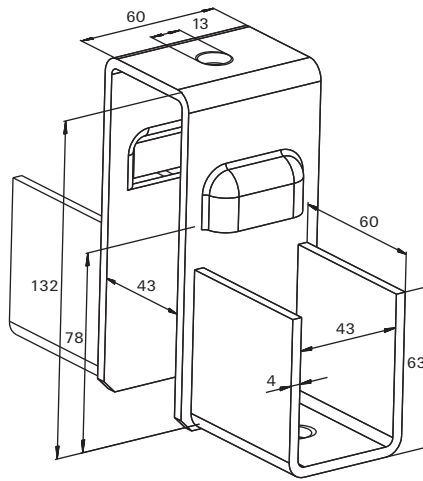

FVS 4

Item	Art.-No.	For profile	Sales unit
			[pcs]
FVS 3	505549	FUS 62 + FUS 62 D	8
FVS 4	505550	FUS 62 + FUS 62 D	5

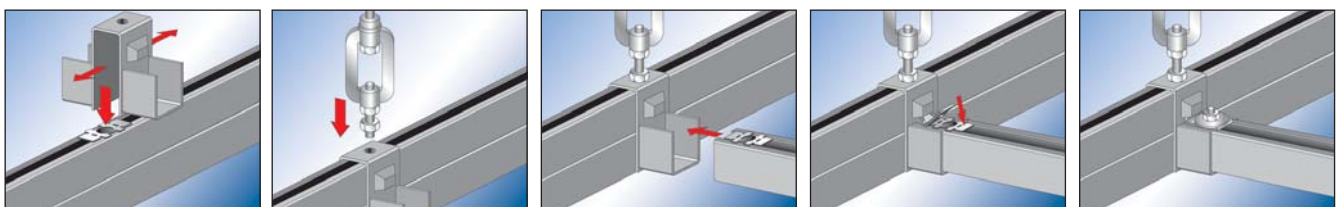

FUS 62, FUS 62 D



Item	Art.-No.	Length	Profile thickness	Weight	Sales unit
		l [mm]	[mm]	[kg/m]	[pcs]
FUS 62/2,5 - 6 m	504457	6000	2,5	3.27	1
FUS 62D/2,5 - 6 m	504460	6000	2,5	6.55	1

Characteristics see on page 114

FUF OC



Item	Art.-No.	Length	Thickness	Sales unit
		l [mm]	S [mm]	[pcs]
FUF OC 62	504518	400	4	10

Characteristics see on page 119

HK 41



Item	Art.-No.	Sales unit		
		[pcs]		
HK 41 12,5	504354	50		

Characteristics see on page 143

GM 12/3



Item	Art.-No.	Length l [mm]	Thread A	Sales unit [pcs]
G 12/3	064056	3000	M 12	5

Characteristics see on page 192

MU



Item	Art.-No.	Thread A	Width across nut ○ SW [mm]	Sales unit [pcs]
MU M 12	024650	M 12	19	100

Characteristics see on page 202

U



Item	Art.-No.	Thickness S [mm]	Hole diameter D [mm]	Sales unit [pcs]
U 12 x 40	024649	3	12.5	100

Characteristics see on page 201

5 Installation Grid

VM M 12



Item	Art.-No.	Thread A	Sales unit [pcs]
VM M 12	020971	M 12	100

Characteristics see on page 202

SPS / BLR



Item	Art.-No.	Thread A	Sales unit [pcs]
SPS M 12	064090	M 12	25
BLR 100 M12	064091	M 12	25

Characteristics see on page 200

TKR



Item	Art.-No.	For profile	Sales unit [pcs]
TKR 124	504367	62 D	10

Characteristics see on page 151

UHRS

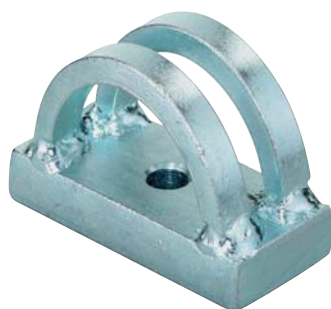

5

Item	Art.-No.	Sales unit [pcs]		
UHRS	063938	6		

Characteristics see on page 148

FHS CLIX-S



Item	Art.-No.	Thread A	Sales unit [pcs]	
FHS CLIX S 12 x 30	020969	M 12	50	

Characteristics see on page 140

FEC 62 B



Item	Art.-No.	Material	Sales unit [pcs]	
FEC 62 B	505551	polyethylene, black	100	

Characteristics see on page 125

FCN CLIX P 12



Item	Art.-No.	Thread A	Sales unit [pcs]	
FCN Clix P 12	504331	M 12	100	

Characteristics see on page 138

FCN 12









Item	Art.-No.	Thread A	Sales unit [pcs]	
FCN 12	077411	M 12	100	

Characteristics see on page 142



6

Fixpoint and Sliding Elements

	page		page
Fix points			
Sound insulated fix point FSFP	168		
Fixpoint clamp FFPS and -saddle FFPK	169		
Sliding elements			
Sliding element GL	170		
Sliding saddle SBS	171		
		Sliding element FSC1	172
			
		Sliding hanger SB	173
			
		Pendulum hanger PDH / PDH K	174
			



APPLICATIONS

- Prevention of unwanted displacement between the pipes and the structures
- Ensuring of the expansion into the desired direction

ADVANTAGES/BENEFITS

- The fixpoint's ageing-resistant insulation elements is heat resistant and isolates the structure from sound transfer.
- The fully pre-mounted FSFP fixpoint ensures a quick and easy installation.
- The compact design of the fixpoint leads to high pipe loads in all fitting positions.

PROPERTIES

- **Clamp strap:** ST W22 (m+L34aterial no. 1.0032)
- **Base plate:** S235 JR (material no. 1.0038)
- **Zinc plating:** electro zinc-plated, min. 5 µm
- **Elastomer:** ISO 1629 SBR/EPDM chlorine-free and silicone-free
- **Temperature range:** -40 °C to +100 °C

TECHNICAL DATA

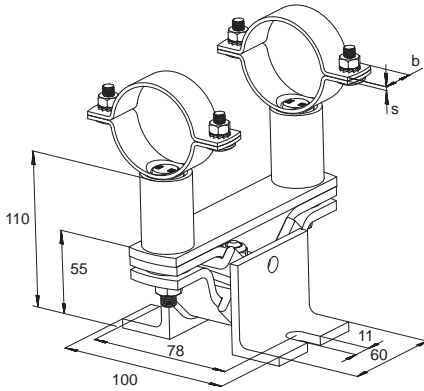

Item	Art.-No.	Size [inch]	Clamping range D [mm]	Locking screw	Width x thickness clamp band b x s [mm]	Sales unit [pcs]
FSFP 1"	512716	1"	33,7	M 6	20 x 1,5	1
FSFP 1 1/4"	512717	1 1/4"	42,4	M 6	20 x 2,0	1
FSFP 1 1/2"	512718	1 1/2"	48,3	M 6	20 x 2,0	1
FSFP 2"	512719	2"	60,3	M 8	30 x 2,5	1
FSFP 2 1/2"	512720	2 1/2"	76,1	M 8	30 x 2,5	1
FSFP 3"	512721	3"	88,9	M 8	30 x 2,5	1
FSFP 4"	512722	4"	114,3	M 8	30 x 2,5	1

LOADS

Item	Art.-No.	max. recommended load F _{rec} [kN]
FSFP 1"	512716	4.0
FSFP 1 1/4"	512717	4.0
FSFP 1 1/2"	512718	4.0
FSFP 2"	512719	4.0
FSFP 2 1/2"	512720	4.0
FSFP 3"	512721	4.0
FSFP 4"	512722	4.0

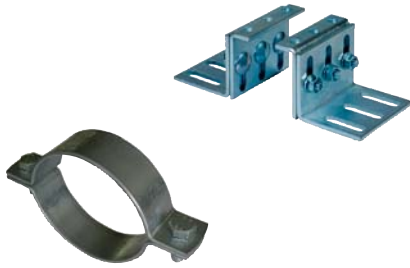

Fixpoint-pipecollar

APPLICATIONS

- Prevention of unwanted displacement between the pipes and the structures
- Ensuring of the expansion into the desired direction

ADVANTAGES/BENEFITS

- The system's modular design allows it to be adjusted to the required loads.
- The system's high load level enables increased fixing distances.
- The fixpoint saddle allows a height and angle adjustment.
- The special washers on the clamp and console ensure a quick installation.

PROPERTIES

- **FFPS:** S 185-Z-150 NA-NK (material no. 1.0035) acc. to DIN EN 10035
- **FFPK:** S235 JR (material no. 1.0037) acc. to DIN EN 10025
- **Zinc plating:** electro zinc-plated, min. 5 μm

TECHNICAL DATA

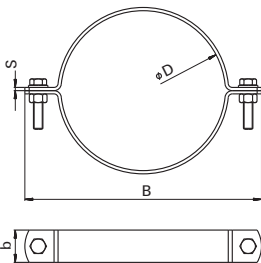

FFPS

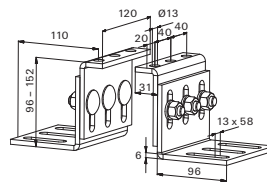

FFPK

Item	Art.-No.	Size [inch]	Clamping range D [mm]	Width B [mm]	Locking screw	Width x thickness clamp band b x s [mm]	Tightening torque T_{inst} [Nm]	Sales unit [pcs]
FFPS 2"	048510	2"	56 - 61	137	M 12	40 x 4,0	60	1
FFPS 2 1/2"	048511	2 1/2"	75 - 80	156	M 12	40 x 4,0	60	1
FFPS 3"	048512	3"	88 - 93	170	M 12	40 x 4,0	60	1
FFPS 4"	048513	4"	108 - 115	191	M 12	40 x 4,0	60	1
FFPS 5"	048660	5"	133 - 140	217	M 12	40 x 4,0	60	1
FFPS 159 - 166	048662	159 - 166	159 - 166	243	M 12	40 x 4,0	60	1
FFPS 6"	048663	6"	167 - 172	250	M 12	40 x 4,0	60	1
FFPS 8"	048664	8"	219 - 225	303	M 12	40 x 4,0	60	1
FFPS 10"	048665	10"	267 - 274	351	M 12	40 x 4,0	60	1
FFPK	048666	—	—	—	—	—	—	1

LOADS

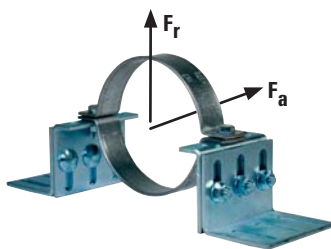

Point fixe 1 collier
Max. recom. load
axial $F_a = 5500$ N
radial $F_r = 4660$ N

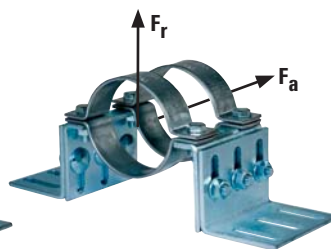

Fixpoint 2 clamps
Max. recom. load
axial $F_a = 11000$ N
radial $F_r = 9320$ N

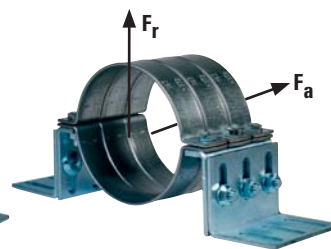

Fixpoint 3 clamps
Max. recom. load
axial $F_a = 16500$ N
radial $F_r = 13980$ N

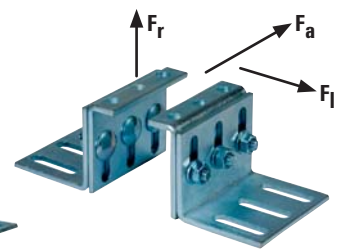

FFPK
Saddle max. recom. loads
radial $F_r = 42000$ N
lateral $F_l = 17500$ N



APPLICATIONS

- Sliding element with a maximum sliding distance of 160 mm for the absorption of axial length adjustments and expansion to pipelines

ADVANTAGES/BENEFITS

- The low height of the sliding element allows a space-saving installation.
- The large sliding distance of the sliding element enables large expansion distances.
- The twin pipe support prevents pipes from moving in the wrong direction.

PROPERTIES

- **Material:** steel S235 JR (material no.: 1.0037) acc. to DIN EN 10025
- **Zinc plating:** electro zinc-plated, min. 8 µm
- **Material sliding strips:** Nylon 6
- **Adhesion friction factor:** 0,27 - 0,3
- **Sliding friction factor:** 0,15 - 0,25
- **Thermal load capacity:** -30 °C to +110 °C

TECHNICAL DATA

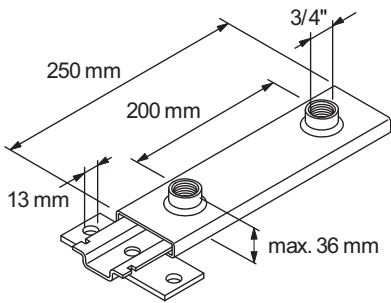

GLL 3/4"

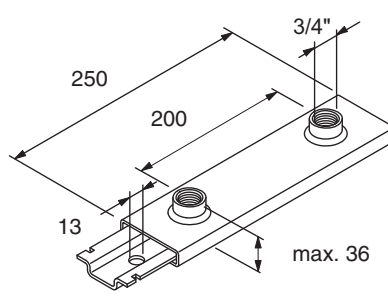

GL 3/4"

Item	Art.-No.	Sales unit [pcs]			
GLL 3/4"	064038	5			
GL 3/4"	064041	5			

LOADS

Item	Art.-No.	Max. recom. load values		Max. recom. pipe-Ø
		suspended [kN]	vertical [kN]	
GLL 3/4"	064038	3,50	4,00	200
GL 3/4"	064041	3,50	4,00	200



Sliding element on cantilever

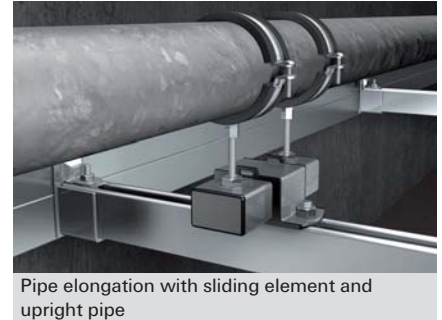

Pipe elongation with sliding element and upright pipe

APPLICATIONS

- Absorption of pipe expansions on two points
- Sliding distance for SBS 55 mm (M 10) and 60 mm (M 8), SBS 12/16 125 mm

ADVANTAGES/BENEFITS

- The two point pipe support prevents pipes from slipping of the duct.
- The low height of the sliding saddle allows a space-saving installation.

CERTIFICATES



PROPERTIES

- **Material:** steel DD11 (material no. 1.0332) acc. to DIN EN 10111 / PA GF 20
- **Zinc plating:** electro zinc-plated, min. 5 µm
- **Adhesion friction factor:** 0,25 - 0,30
- **Sliding friction factor:** 0,16 - 0,18
- **Temperature range:** -40 °C to +100 °C

TECHNICAL DATA

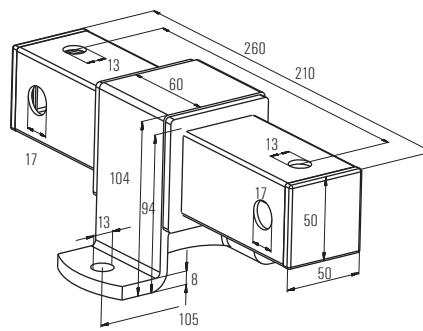
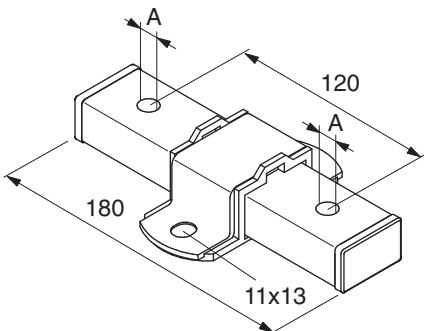

SBS

SBS 12/16

Item	Art.-No.	Fire test report	Thread	Sales unit
			A	[pcs]
SBS M 8	079685	—	M 8	8
SBS M 10	079686	X	M 10	8
SBS 12/16	047726	X	M 12 / M 16	1

LOADS

Item	Art.-No.	Max. recom. load values, suspended		Max. recom. load values, vertical	
		[kN]	[kN]	[kN]	[kN]
SBS M 8	079685	1,50	1,50	1,50	1,50
SBS M 10	079686	1,50	1,50	1,50	1,50
SBS 12/16	047726	7,8	7,8	7,8	7,8

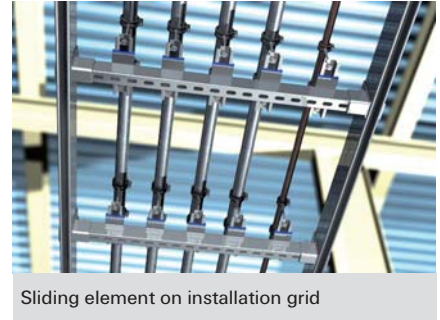

APPLICATIONS

- Sliding element with a maximum sliding distance of 100 mm for the large axial expansion of pipelines

ADVANTAGES/BENEFITS

- The holes in the sliding saddle allow the use as a single or double sliding element.
- The special design of the base plate prevents a sliding out.

PROPERTIES

- **Material:** steel DD11 (material no. 1.0332) acc. to DIN EN 10111
- **Zinc plating:** electro zinc-plated, min. 5 µm
- **Temperature range:** -30 °C to +120 °C

TECHNICAL DATA

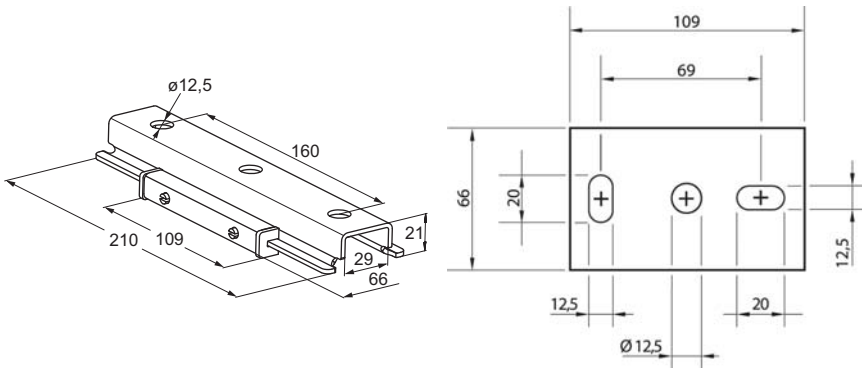

Item	Art.-No.	Sales unit [pcs]			
FSC 1	507866	12			

LOADS

Item	Art.-No.	Max. recommended static load (suspended)	Max. recommended static load (upright)
		N_{rec} [kN]	N_{rec} [kN]
FSC 1	507866	1.3	1.0



APPLICATIONS

- Adjustments of axial length to pipe-lines
- Installation of sliding elements in line with the expected length expansions (Ensuring that no sliding distance is lost and sliding isn't inhibited)

ADVANTAGES/BENEFITS

- The design of the sliding hanger allows pipes to be mounted securely and easily.
- The sliding hanger is ideally suited to adjust the axial length of pipelines.

CERTIFICATES

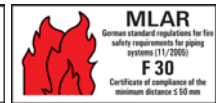

PROPERTIES

- **Material:** steel DD11 (material no. 1.0332) acc. to DIN EN 10111
- **Zinc plating:** electro zinc-plated, min. 3 µm

TECHNICAL DATA

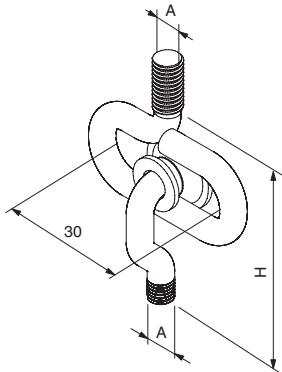

Item	Art.-No.	Fire test report	Thread	Height H	Sales unit
			A1	H	
				[mm]	[pcs]
SB M 8	079680	—	M 8	75	25
SB M 10	079681	X	M 10	90	25

LOADS

Item	Art.-No.	Max. recom. statc load (centr. tension)
		[kN]
SB M 8	079680	0.40
SB M 10	079681	0.65



6

Fixpoint and Sliding Elements

APPLICATIONS

- Single fixing for the absorption of pipeline length adjustments in any direction
- Installation of the pendulum in pairs for pipe movement without tipping
- Secure threaded rod with lock nut to prevent loosening

ADVANTAGES/BENEFITS

- The design of the pendulum hanger allows a rotation of 360°.
- The pendulum hanger's screw-in sleeve allows for large height adjustments.
- The max. pendulum angle of 12° enables the absorption of large expansions.
- The screw-in depth of the threaded bolts guarantees a high tension load.

CERTIFICATES



PROPERTIES

- **Material:** steel DD11 (material no. 1.0332) acc. to DIN EN 10111
- **Zinc plating:** electro zinc-plated, min. 5 µm

TECHNICAL DATA

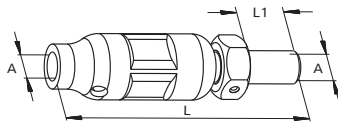

Item	Art.-No.	Fire test report	Thread	Length	Length	Sales unit
			A1	L	L1	
				[mm]	[mm]	[pcs]
PDH K M 8	068267	—	M 8	50	18	50
PDH K M 10	068269	X	M 10	54	18	50
PDH M 8	079676	—	M 8	76	18	50
PDH M 10	079677	X	M 10	80	18	50
PDH M 12	064037	X	M 12	90	20	25



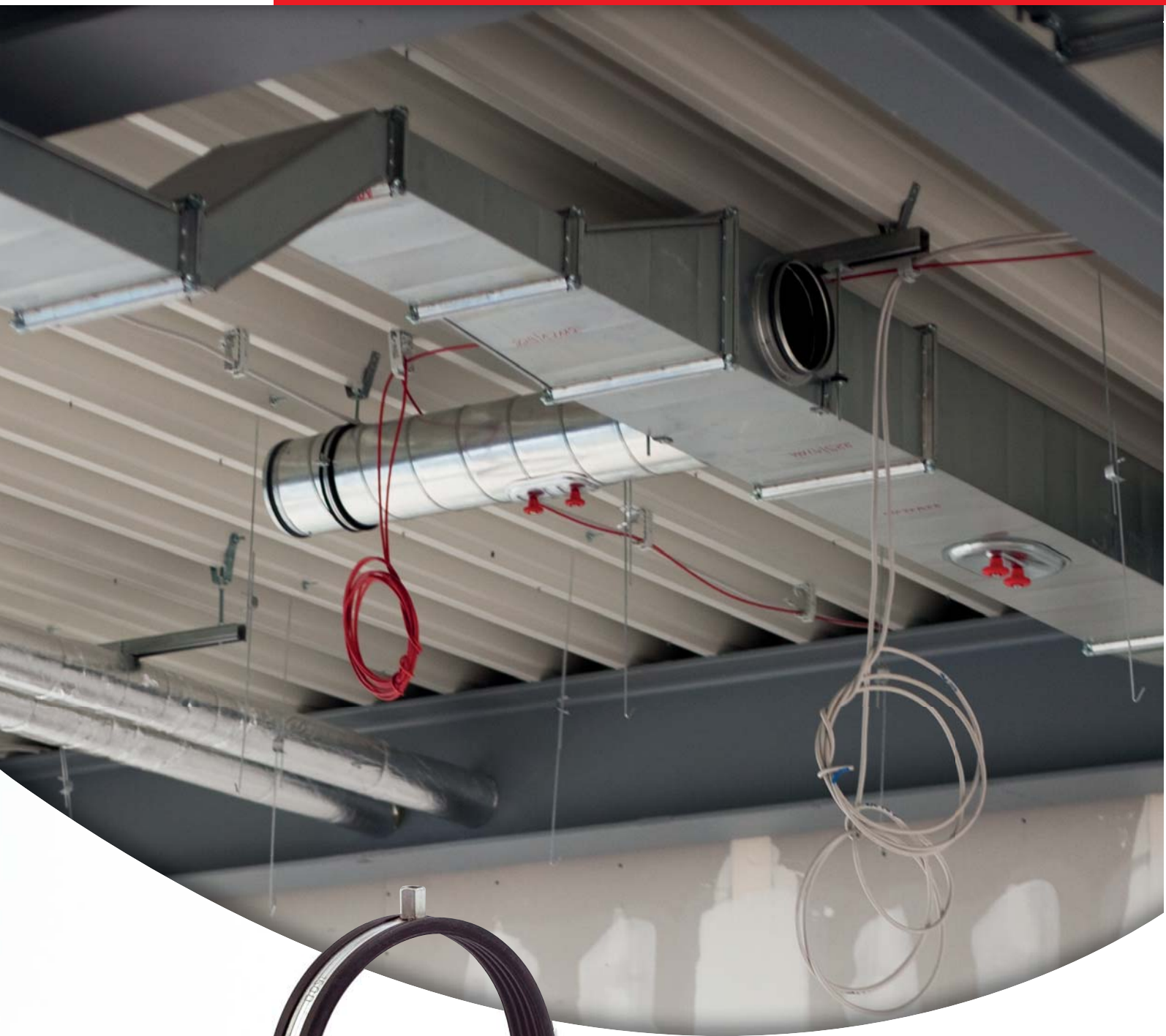

LOADS

Item	Art.-No.	Max. recom. statc load (centr. tension)
		[kN]
PDH K M 8	068267	2.4
PDH K M 10	068269	3.0
PDH M 8	079676	2.4
PDH M 10	079677	3.0
PDH M 12	064037	3.5



7

Air duct and Metal roof fixings

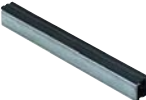
	page		page
Clamps		Metal ceiling hanger	
Ventilation duct clamp LGS	 178	Profile hanger TZ / TZH	 182
Fastening components		Hole punch LZ, hole stamp LST	 183
Duct hanger L- and Z-type	 180		
Spiral duct hanger LRBN / LRB	 181		
Rubber inlay EMS	 184		

Clamps - Ventilation duct clamp LGS



Support systems for ventilation



Spiral airtight duct on cantilever

7

APPLICATIONS

- Fixing of spiral lock seam pipes and plastic pipes
- Fixing of pipes over 450 mm in diameter with two adjacent threaded rods
- Sound-insulation insert is held glued from Ø450 mm

ADVANTAGES/BENEFITS

- The large opening angle of the LGS enables a quick and easy installation.
- The LGS's two screws allow the adjustment to suit the outer pipe diameter.
- The locking screw with large recess/cross recess head is secured to not get lost during installation.
- The sound-insulation insert has a form fit and can not fall out during the adjustment of the pipe.
- The LGS is drilled on both sides of the clamp from 450 mm diameter on. This allows for connection with two screws with nuts or two threaded rods with nuts. Thereby the recommended load of the clamp can be doubled.

PROPERTIES

- **Material:** steel DX51D+Z 275 MA-C (material no. 1.0226+Z) acc. to DIN EN 10327
- **Zinc plating:** sendzimir-galvanised, app. 15 µm
- **Connecting nut:** resistance welded domed nut, M8 / M10, SW 13
- **Locking screw:** oval head screw with combination recessed head
- **Material sound insulation insert:** SBR/EPDM; chlorine-free; silicone-free
- **Sound insulation:** for DIN 4109
- **Temperature range:** -50 °C to +110 °C
- **Hardness:** 45 ± 5° Shore A
- **Fire behaviour:** DIN 4102: Class B2

Airtight and Metal roof fixings

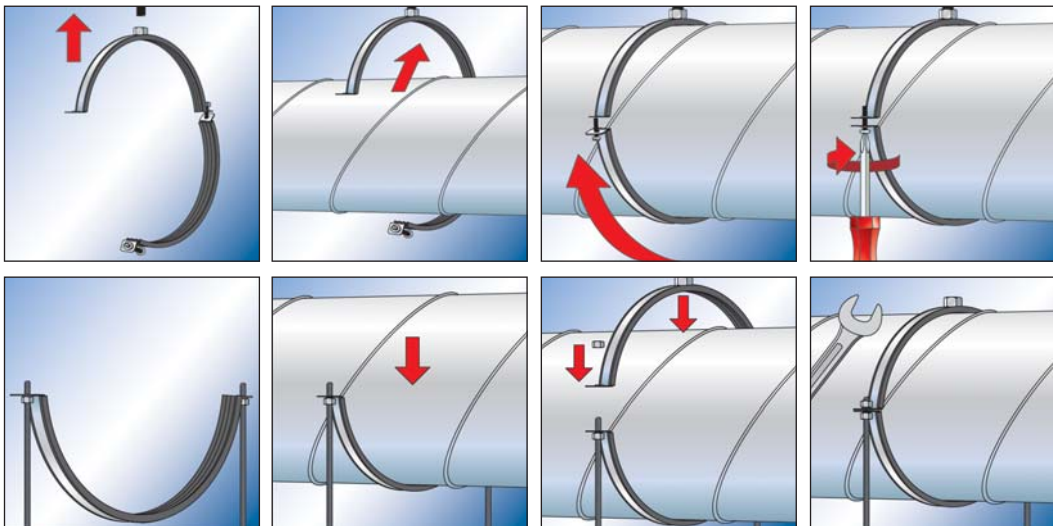

TECHNICAL DATA

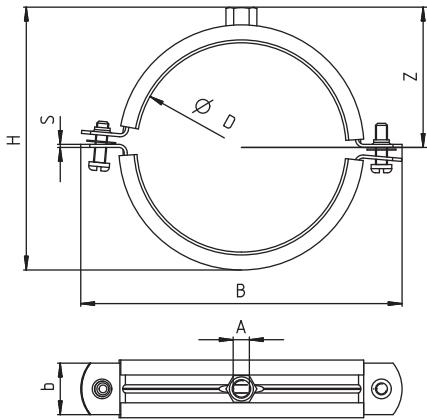

Item	Art.-No.	Thread	Size	Height H	Width B	Width x thickness clamp band	Height Z	Locking screw	Max. recom. static load (centr. tension)	Sales unit
		A	[mm]	H [mm]	B [mm]	b x s [mm]	Z [mm]			
LGS 80	079491	M 8 / M 10	80	110	134	25 x 1,25	62	M 6	0.6	25
LGS 90	079492	M 8 / M 10	90	120	144	25 x 1,25	67	M 6	0.6	25
LGS 100	079493	M 8 / M 10	100	131	155	25 x 1,25	72	M 6	0.6	20
LGS 112	079494	M 8 / M 10	112	143	167	25 x 1,25	78	M 6	0.6	20
LGS 125	079495	M 8 / M 10	125	156	180	25 x 1,25	85	M 6	0.6	10
LGS 140	079496	M 8 / M 10	140	171	195	25 x 1,25	92	M 6	0.6	10
LGS 150	079497	M 8 / M 10	150	181	205	25 x 1,25	97	M 6	0.6	10
LGS 160	079498	M 8 / M 10	160	191	215	25 x 1,25	102	M 6	0.6	10
LGS 180	079499	M 8 / M 10	180	211	235	25 x 1,25	112	M 6	0.6	10
LGS 200	079500	M 8 / M 10	200	231	255	25 x 1,25	122	M 6	0.6	15
LGS 224	079501	M 8 / M 10	224	255	279	25 x 1,5	134	M 6	0.6	15
LGS 250	079502	M 8 / M 10	250	281	305	25 x 1,5	147	M 6	0.6	10
LGS 280	079503	M 8 / M 10	280	311	335	25 x 1,5	162	M 6	0.6	10
LGS 300	079504	M 8 / M 10	300	331	356	25 x 1,5	172	M 6	0.6	10
LGS 315	079505	M 8 / M 10	315	347	371	25 x 1,5	180	M 6	0.6	10
LGS 355	079506	M 8 / M 10	355	387	411	25 x 1,5	200	M 6	0.6	10
LGS 400	079507	M 8 / M 10	400	431	456	25 x 1,5	222	M 6	0.6	10
LGS 450	024637 1)	M 8 / M 10	450	485	524	25 x 2,5	247	M 10	0.8	1
LGS 500	024638 1)	M 8 / M 10	500	535	574	25 x 2,5	272	M 10	0.8	1
LGS 560	024639 1)	M 8 / M 10	560	595	634	25 x 2,5	302	M 10	0.8	1
LGS 600	024640 1)	M 8 / M 10	600	635	674	25 x 2,5	322	M 10	0.8	1
LGS 630	024641 1)	M 8 / M 10	630	665	705	25 x 3,0	338	M 10	0.8	1
LGS 710	024642 1)	M 8 / M 10	710	745	785	25 x 3,0	378	M 10	0.8	1
LGS 800	024643 1)	M 8 / M 10	800	835	875	25 x 3,0	423	M 10	0.8	1
LGS 900	024644 1)	M 8 / M 10	900	935	975	25 x 3,0	473	M 10	0.8	1
LGS 1000	024645 1)	M 8 / M 10	1000	1035	1075	25 x 3,0	523	M 10	0.8	1
LGS 1120	024646 1)	M 8 / M 10	1120	1155	1195	25 x 3,0	583	M 10	0.8	1
LGS 1250	024647 1)	M 8 / M 10	1250	1285	1326	25 x 3,0	648	M 10	0.8	1

1) The installation with two threaded rods allows to double the given recommended loads.

Fastening components - Duct hanger L- and Z-type



7

Airduct and Metal roof fixings

APPLICATIONS

- Fastening component with sound-insulation

ADVANTAGES/BENEFITS

- The ceiling hanger's sound-insulation element reduces the transfer of vibration and noise.
- The multiple holes on the ceiling attachments allow a quick and easy fastening with self-drilling screws or rivets.
- The through hole in the ceiling hangers allows a simple alignment and height adjustment of the threaded rod.

PROPERTIES

- Material:** steel DD11 (material no. 1.0332) acc. to DIN EN 10111
- Zinc plating:** electro zinc-plated, min. 3 µm
- Sound insulation:** for DIN 4109
- Temperature range:** -50 °C to +110 °C
- Hardness:** 45 ± 5° Shore A
- Fire behaviour:** DIN 4102: Class B2

TECHNICAL DATA

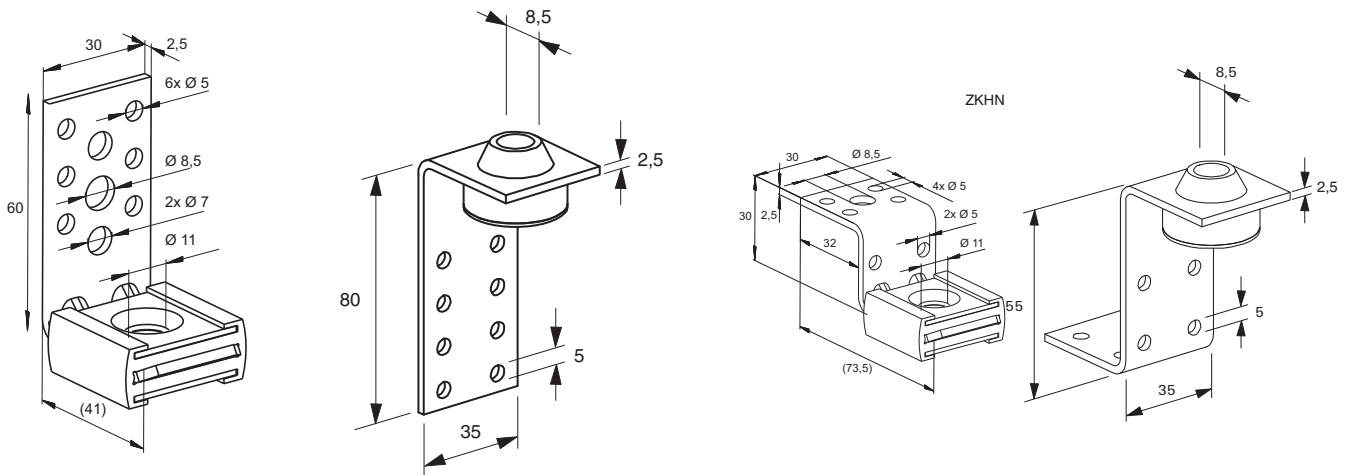

LKHN

LKH

ZKHN

ZKH

Item	Art.-No.	For thread	Max. recom. static load (centr. tension) N _{recom.} [kN]	Sales unit [pcs]
LKHN	516537	M 8 / M 10	0.90	50
LKH	024671	M 8	0.50	50
ZKHN	516540	M 8 / M 10	0.90	50
ZKH	024674	M 8	0.50	50

Fastening components - Spiral duct hanger LRB and LRBN



APPLICATIONS

- Fastening component with sound-insulation (riveted and inserted versions)

ADVANTAGES/BENEFITS

- The multiple holes on the duct hangers allow a quick and easy fastening with self-drilling screws or rivets.
- The duct hangers sound-insulation element reduces the transfer of vibration and noise.
- The through hole in the duct hangers allows the simple alignment and height adjustment of the threaded rod.
- The riveted version gives the ceiling hanger increased stability.
- The specified shape of the duct hangers allow an ideal adjustment to suit the pipe diameter.
- The design of the LRN / LRNB offers an alternative use as a sound-insulated profile hanger.

PROPERTIES

- Material LRB:** steel DD11 (material no. 1.0332) acc. to DIN EN 10111
- Zinc plating LRB:** electro zinc-plated, min. 3 µm
- Material LRBN:** steel S235 JR (material no. 1.0037) acc. to DIN EN 10025
- Zinc plating LRBN:** electro zinc-plated, min. 8 µm
- Sound insulation:** for DIN 4109
- Temperature range:** -50 °C to +110 °C
- Hardness:** 45 ± 5° Shore A
- Fire behaviour:** DIN 4102: Class B2

TECHNICAL DATA

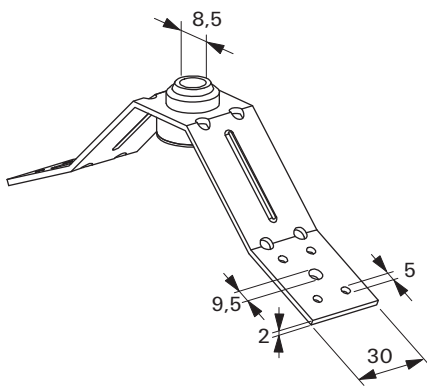

LRB

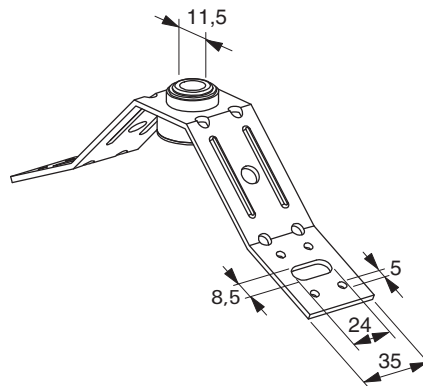

LRBN

Item	Art.-No.	For thread	Max. recom. statc load (centr. tension) [kN]	Sales unit [pcs]
LRB	024675	M 8	0.5	50
LRBN	077613	M 8 / M 10	0.9	50

Metal ceiling hanger - Profile hanger TZ / TZA / TZH



7

Airduct and Metal roof fixings

APPLICATIONS

- Fastening element for trapezoidal sheets (available in three versions)
- Sprinkler system version to be fixed with screw SKS M8x100 in punched hole
- Fixing of pipes with self drilling screws or steel blind rivets

ADVANTAGES/BENEFITS

- The VdS approval for TZ/TZH and the FM approval for the TZA guarantee independently tested safety.
- The TZH's adjustable nut allows a simple, post-installation height adjustment.
- The specified bending points of the TZ/TZH/TZA allow the ideal adjustment to suit the shape of the trapezoidal sheet.

CERTIFICATES



G 410037 / G 410034



From thread M10.

PROPERTIES

- **Material:** steel DX51D+Z 140-275 (material no. 1.0226+Z) acc. to DIN EN 10327; DD11 acc. to DIN EN 10111
- **Zinc plating:** electro zinc-plated, $\geq 7 \mu\text{m}$

TECHNICAL DATA

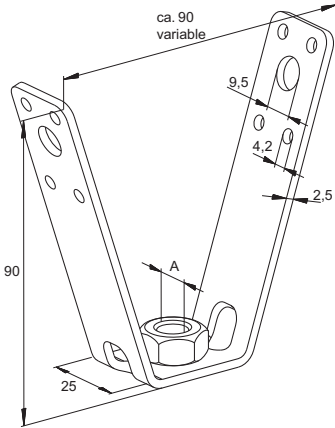

TZ

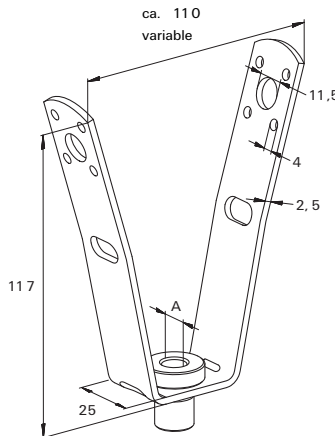

TZH

Item	Art.-No.	VdS approved	FM approved	Thread	Max. recom. statc load (centr. tension)	Sales unit
				A	[kN]	[pcs]
TZ M 8	064094	X	—	M 8	3.0	25
TZ M 10	064095	X	—	M 10	3.0	25
TZA M10	524047	—	X	M 10	3.0	50
TZH M 8	079825	X	—	M 8	4.0	25
TZH M 10	079826	X	—	M 10	4.0	25

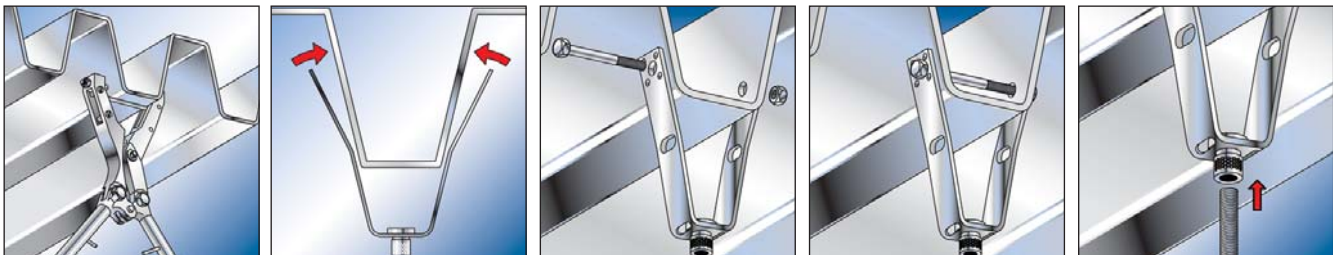



APPLICATIONS

- Tool for punching holes in steel sheets

PROPERTIES

- Usable for trapezoidal steel sheet with max. opening width between stamps of 67 mm

TECHNICAL DATA



Item	Art.-No.	Sales unit [pcs]			
LZ	079830	1			

TECHNICAL DATA



Item	Art.-No.	Sales unit [pcs]			
LST 10	079829	2			

SEE ALSO

 SKS see page 201	 MU see page 202
--	---

Fastening components - Rubber inlay EMS



Air duct with sound insulation on installation channel

7

APPLICATIONS

- Profile rubber to insert in channels
- Sound insulation of large ducting

ADVANTAGES/BENEFITS

- The channel rubber EMS provides sound insulation between components.
- The design of the rubber EMS allows it to be used in channels and threaded rods.

PROPERTIES

- **Material sound insulation:** SBR/EPDM chlorine-free and silicone-free
- **Sound insulation:** special noise-absorbing lining
- **Temperature range:** -50 °C to +110 °C
- **Hardness:** 45 ± 5° Shore A
- **Fire behaviour:** DIN 4102: Class B2

TECHNICAL DATA

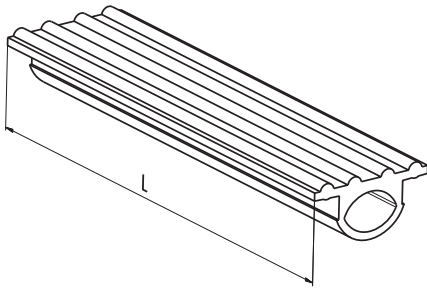











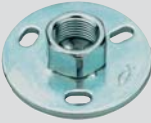

Item	Art.-No.	For profile	Length	Sales unit
			[m]	[pcs]
EMS 31	538752	all FLS channels	25	1
EMS 41	550806	all FUS channels	6	1



8

Accessories

	page		page
Base plates		Threaded connectors	
Base plate GPL 	194	Threaded rod G / Threaded stud GS 	192
Base plate GPR 	194	Hexagonal nut MU 	202
Steel work connectors		Washer U 	201
Clamp hanger TKL 	188	Reduction pieces 	203
Beam Clamp Steel TKLS Steel Bite 	190	Hexagonal screw SKS 	201
Level adjustment		Stud screw STST with bit head and Hex shank 	195
Turnbuckle SPS, Bolt left-hand/right-hand BLR 	200	Straps	
Parallel connector PV 	198	Textile web strapping GWB 	205
Support hanger AHB 	196	Perforated steel banding LBV / LBK 	206
		Impact nail ED 	207

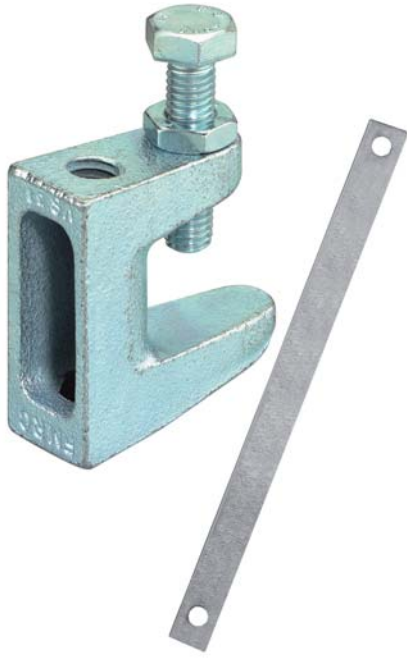

APPLICATIONS

- Clamp hangers allow for simple fixing by clamping direct to steel girders
- Safety plates SS-TKL are required for VdS equipment over \varnothing 65 mm

ADVANTAGES/BENEFITS

- The TKL design with its clamping screw allows for fixing to steel girders without the need for welding and drilling.
- The design of the clamping screw prevents it from slipping from the steel girder.
- VdS/FM/UL certificates guaranty independently tested safety.
- The solid TKL design guarantees a high load-bearing capacity.
- The TKL with locking screw guarantees quick and easy installation.
- The TKL with through-hole allows for height adjustment after installation.

CERTIFICATES



G 410037 / G 410034



PROPERTIES

- **Material TKL:** malleable cast iron EN-GJMB-350-10 acc. to DIN 1562
- **Material bolt:** steel 8.8 acc. to ISO 4017
- **Material nut:** steel acc. to ISO 4035, Strength category 4
- **Material SS-TKL:** steel DX51D (material no. 1.0226) acc. to EN 10214
- **Zinc plating:** electro zinc-plated, min. 5 μ m

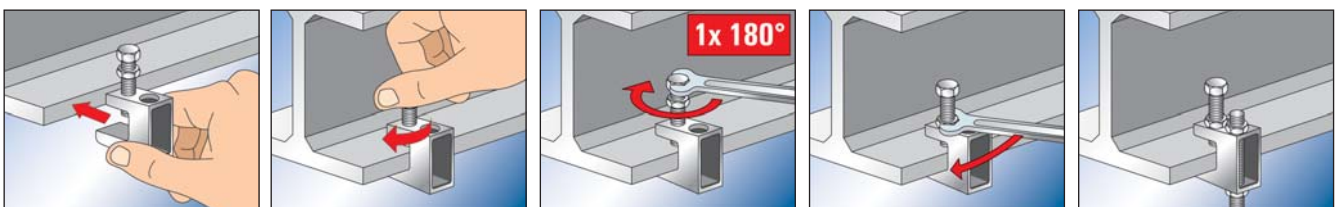

TECHNICAL DATA

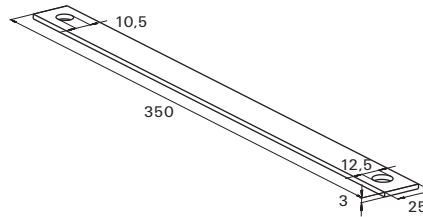
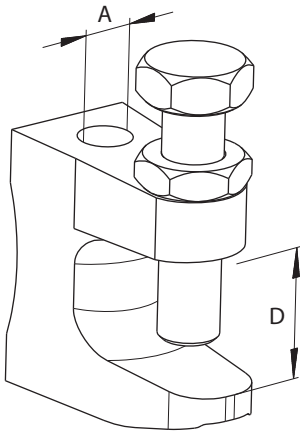

TKL

SS-TKL

Item	Art.-No.	VdS approved	FM approved	UL approved	Clamping range	Thread	Sales unit
					D [mm]	A	[pcs]
TKL L M 8	064055	X	-	-	0 - 18	M 8	50
TKL M 8	079687	X	-	-	0 - 23	M 8	50
TKL L Ø 9	077605	X	-	-	0 - 18	Ø 9	50
TKL M 10	079688	X	X	X	0 - 20	M 10	50
TKL Ø 11	079689	X	X	X	0 - 20	Ø 11	50
TKL M 12	020949	X	X	X	0 - 26	M 12	50
TKL Ø 13	043275	X	X	X	0 - 26	Ø 13	50
SS-TKL M10/M12	048154	X	-	-	-	Ø 10 / Ø 12	25

LOADS

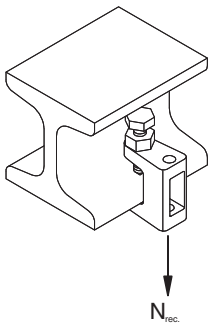

Item	Art.-No.	Max. recom. static load (centr. tension)	
		$N_{recom.}$ [kN]	
TKL L M 8	064055	1.20	
TKL M 8	079687	2.50	
TKL L Ø 9	077605	1.20	
TKL M 10	079688	2.50	
TKL Ø 11	079689	2.50	
TKL M 12	020949	3.50	
TKL Ø 13	043275	3.50	

Beam Clamp allows simple fixing by hammering to steel beams



APPLICATIONS

- All kind of fixings by threaded rods to steel beams with sloping flange plate up to 14%
- Safety plates SS-TKL are required for VdS equipment over \varnothing 65 mm

ADVANTAGES/BENEFITS

- The TKLS design with hammering wedge allows fixing to steel beams without the need of welding and drilling.
- The teeth of the TKLS Steel Bite effectively prevent from slipping of the steel beam.
- VdS and FM approval guarantees objectively tested functional safety.
- The TKLS Steel Bite made of steel guarantees highest load-bearing capacity.
- The TKLS Steel Bite allows pre-assembling of threaded rods and for retrospective height adjustment.

CERTIFICATES



PROPERTIES

- **TKLS: material:** steel HX420LAD+ZAD, material no. 1.0935, DIN EN 10346
- **TKLS: Zinc plating:** electro zinc-plated, min. 7 μ m
- **SS-TKL: Material:** steel DX5 1D acc. to EN 10214, material no.1.0226
- **SS-TKL: Zinc plating:** electro zinc-plated, min. 5 μ m

Accessories

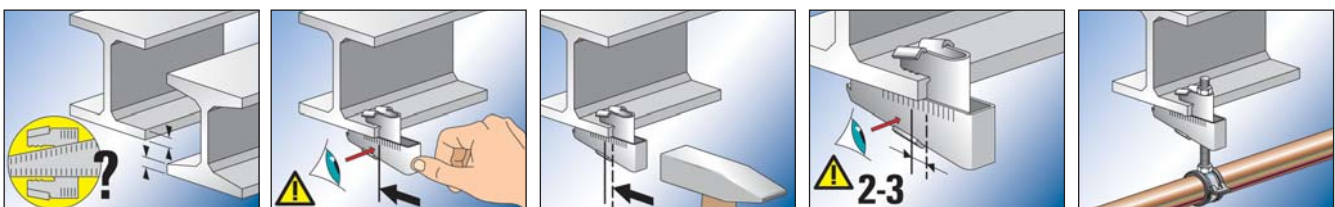

TECHNICAL DATA

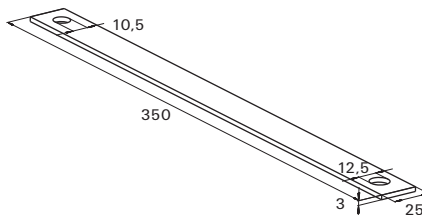
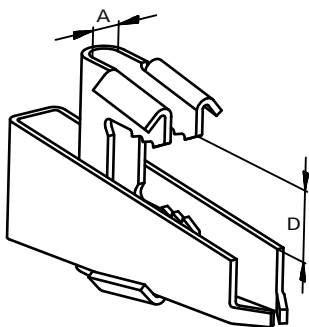

TKLS

SS-TKL

Item	Art.-No.	VdS approved	FM approved	Hole diameter	Clamping range	Sales unit
				A [mm]	D [mm]	[pcs]
TKLS Ø 9	531134	X	–	9	8 - 20	25
TKLS Ø 11	531136	X	X	11	8 - 20	25
TKLS Ø 13	531137	X	X	13	8 - 20	25
TKLS Ø 17	531138	X	X	17	11 - 26	16
SS-TKL M10/M12	048154	X	–	–	–	25

LOADS

Item	Art.-No.	Max. recom. static load (centr. tension)	Max. recom. pipe-Ø acc. VDS CEA 4001
		$N_{\text{recom.}}$ [kN]	
TKLS Ø 9	531134	2.00	≤ DN 50
TKLS Ø 11	531136	3.50	> DN 50 ≤ DN 100
TKLS Ø 13	531137	5.00	> DN 100 ≤ DN 200
TKLS Ø 17	531138	10.00	> DN 200 ≤ DN 250

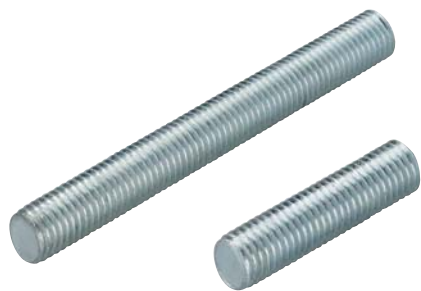

PROPERTIES

- **Material threaded rod G (G 6 - G 24):** DIN 976 steel 4.8 acc. to DIN EN ISO 898-1
- **Material threaded pipe G (G 1/2" - G 3/4"):** steel S235 JR (material no. 1.0037) acc. to DIN EN 10025
- **Material threaded stud GS:** DIN 976 Steel 4.6 acc. to DIN EN ISO 898-1
- **Zinc plating:** electro zinc-plated, min. 3 µm

TECHNICAL DATA

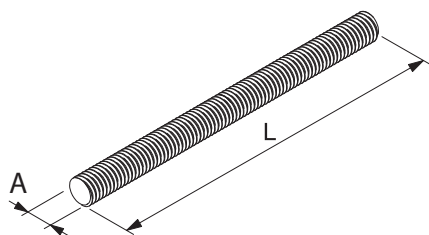

Item	Art.-No.	Length l [mm]	Thread A	Sales unit [pcs]
Threaded rod G				
G 6	020956	1000	M 6	50
G 8	079740	1000	M 8	25
G 10	079744	1000	M 10	25
G 12	020957	1000	M 12	20
G 16	020958	1000	M 16	10
G 20	557295	1000	M 20	5
G 24	557270	1000	M 24	5
G 8/2	079741	2000	M 8	25
G 10/2	079745	2000	M 10	25
G 12/2	579746	2000	M 12	25
G 10/3	557092	3000	M 10	5
G 12/3	064056	3000	M 12	5
Threaded pipe G				
G 1/2"	064093	2000	1/2"	10
G 3/4"	077580	2000	3/4"	5
Threaded stud GS				
GS 8/25	079750	25	M 8	100
GS 8/40	079751	40	M 8	100
GS 8/50	079752	50	M 8	100
GS 8/60	079753	60	M 8	100
GS 8/70	079754	70	M 8	100
GS 8/80	079755	80	M 8	100
GS 8/100	079757	100	M 8	100
GS 8/120	535535	120	M 8	50
GS 8/150	079758	150	M 8	50
GS 8/180	535536	180	M 8	50
GS 8/200	079759	200	M 8	50
GS 10/25	079765	25	M 10	100
GS 10/40	079766	40	M 10	100
GS 10/60	079767	60	M 10	100
GS 10/80	079768	80	M 10	100
GS 10/100	079769	100	M 10	100
GS 10/120	079770	120	M 10	50
GS 10/150	079771	150	M 10	50
GS 10/200	079772	200	M 10	50

TECHNICAL DATA

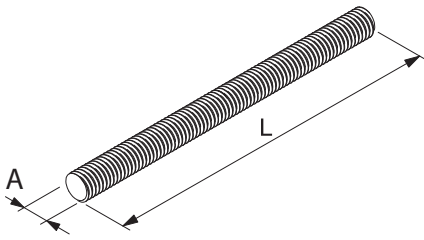

Item	Art.-No.	Length l [mm]	Thread A	Sales unit [pcs]
GS 12/40	091442	40	M 12	100
GS 12/60	091443	60	M 12	100
GS 12/80	091444	80	M 12	100
GS 12/100	091461	100	M 12	100
GS 12/120	091462	120	M 12	50
GS 12/150	091463	150	M 12	50
GS 12/200	091464	200	M 12	50

RECOMMENDED LOAD

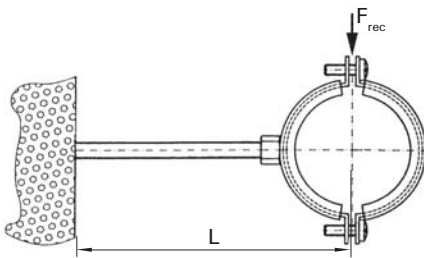

Maximum deflection under load:
Permissible steel tension:

$$f_{\max} \leq 3 \text{ mm}$$

$$\sigma_{\text{ad.}} = 160 \text{ N/mm}^2$$

THREADED RODS (4.6)

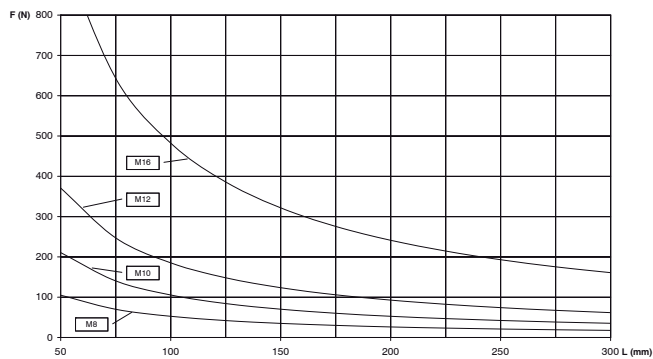

THREADED PIPES

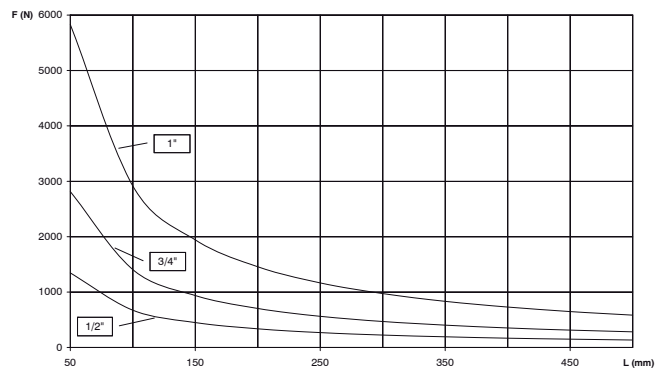



Baseplate on installation channel



Plastic pipe with fixpoint installation

APPLICATIONS

- Base plate in a light, heavy and round version with welded-on threaded sleeve

ADVANTAGES/BENEFITS

- The base plate's slots allow easy alignment.

PROPERTIES

- **Material:** steel DD11 (material no. 1.0332) acc. to DIN EN 10111
- **Zinc plating:** electro zinc-plated, min. 8 µm

TECHNICAL DATA

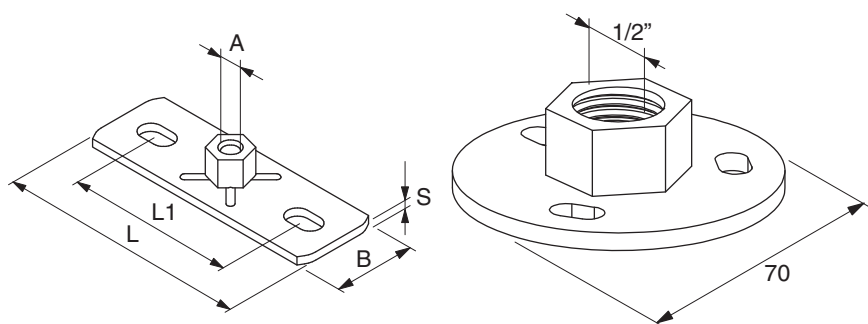

GPL

GPR

		Thread	Length	Width B	Hole spacing	Slot	Thickness	Sales unit
		A	l	B	L1	L x s	S	[pcs]
Item	Art.-No.		[mm]	[mm]	[mm]	[mm]	[mm]	
GPL M 8	079665	M 8	80	30	54	9 x 16	3	25
GPL M 10	079666	M 10	80	30	54	9 x 16	3	25
GPL 1/2"	079667	1/2"	80	30	54	9 x 16	3	25
GPS M 10	079671	M 10	120	40	79	11 x 19	4	25
GPS M 12	040398	M 12	120	40	79	11 x 19	4	25
GPS M 16	504408	M 16	120	40	79	11 x 19	4	25
GPS 1/2"	079672	1/2"	120	40	79	11 x 19	4	25
GPS 3/4"	020968	3/4"	120	40	79	11 x 19	4	25
GPR 1/2"	037289	1/2"	–	–	–	11 x 7	4	25

LOADS

Item	Art.-No.	Max. recom. static load (centr. tension)	
			N _{recom.} [kN]
GPL M 8	079665		2.40
GPL M 10	079666		2.40
GPL 1/2"	079667		2.40
GPS M 10	079671		4.00
GPS M 12	040398		4.00
GPS M 16	504408		4.00
GPS 1/2"	079672		4.00
GPS 3/4"	020968		4.00
GPR 1/2"	037289		4.00

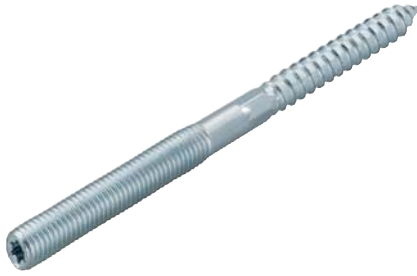

APPLICATIONS

- Threaded connectors stud screw STST
- Wood and metric screw combination for direct installation of clamps onto a wall

ADVANTAGES/BENEFITS

- Fixing with a Nylon plug to brick or direct into timber construction is simple with the torx drive or the integrated hexagon.

PROPERTIES

- **Material:** steel 4.6 acc. to DIN EN ISO 898-1
- **Zinc plating:** electro zinc-plated, min. 3 µm

TECHNICAL DATA

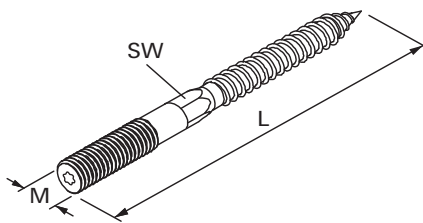

Item	Art.-No.	Length	Thread	Drive	Width across nut	Sales unit
		l [mm]	M		○SW [mm]	
STST 6 x 60	504400 1)	60	M 6	T15	–	100
STST 6 x 80	077714 1)	80	M 6	T15	–	100
STST 8 x 50	079780	50	M 8	T25	6	100
STST 8 x 60	079781	60	M 8	T25	6	100
STST 8 x 80	079782	80	M 8	T25	6	100
STST 8 x 100	079783	100	M 8	T25	6	100
STST 8 x 120	079784	120	M 8	T25	6	100
STST 8 x 140	079785	140	M 8	T25	6	50
STST 8 x 180	079786	180	M 8	T25	6	50
STST 10 x 60	077689	60	M 10	T25	8	100
STST 10 x 80	077707	80	M 10	T25	8	100
STST 10 x 100	077708	100	M 10	T25	8	100
STST 10 x 120	077709	120	M 10	T25	8	100
STST 10 x 140	077711	140	M 10	T25	8	50
STST 10 x 180	077712	180	M 10	T25	8	50
STST 12 x 100	535541	100	M 12	T30	10	100
STST 12 x 160	535542	160	M 12	T30	10	50

1) without hex shank

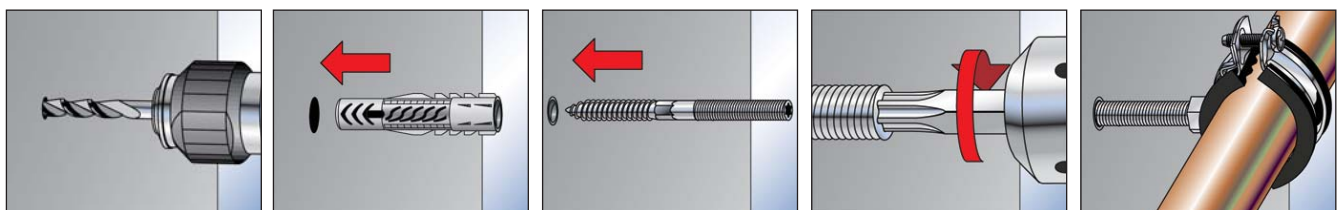



Height adjustable pipe installation

APPLICATIONS

- Component for height adjustment
- The slotted opening means that a component can be easily mounted and adjusted using a threaded rod and nut
- A washer should be used when using size M8 threaded rods

ADVANTAGES/BENEFITS

- The support hanger allows for height adjustment once installed.
- The base plate's long slot allows the support hanger to be easily aligned.

PROPERTIES

- **Material:** steel DD11 (material no. 1.0332) acc. to DIN EN 10111
- **Zinc plating:** electro zinc-plated, min. 5 µm

TECHNICAL DATA

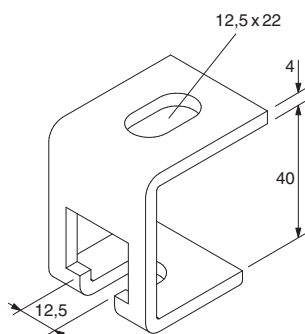

Item	Art.-No.	For thread	Sales unit [pcs]
AHB	079675	M8, M10, M12	25

LOADS

Item	Art.-No.	Max. recom. static load (centr. tension) $N_{recom.}$ [kN]	
AHB	079675	1.20	



Fixation with multi-connector

APPLICATIONS

- Cube with four threaded drill holes for simple connection
- Ideal for connecting threaded rod and bolts at 90°

ADVANTAGES/BENEFITS

- The design of the mounting cube provides flexibility when it comes to connecting pipe clamps or threaded rods.
- The mounting cube allows for the simultaneous fixing of 3 pipelines.

PROPERTIES

- **Material:** diecasting

TECHNICAL DATA

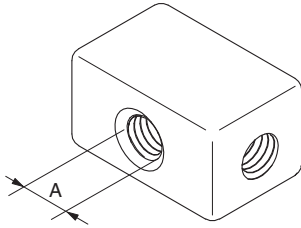

Item	Art.-No.	Thread	Sales unit
		A	[pcs]
MW M 8	079717	M 8	50

LOADS

Item	Art.-No.	Max. recom. static load (centr. tension)	
		$N_{recom.}$ [kN]	
MW M 8	079717	2.50	



APPLICATIONS

- Simple, quick-mount connector for extending and connecting threaded rods
- Parallel connector for extending threaded rods
- Secure using locking nut
- Height can be adjusted by rotating the threaded rod

ADVANTAGES/BENEFITS

- The parallel connector's design allows the threaded rods to be installed quickly.
- Designed for simple and fast height adjustment.
- The PV allows the height to be adjusted during installation.

PROPERTIES

- **Material:** diecast

TECHNICAL DATA

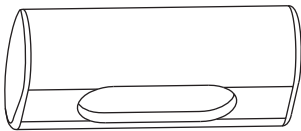

Item	Art.-No.	For thread	Sales unit
			[pcs]
PV M 6	020947	M 6	100
PV M 8	079678	M 8	100

LOADS

Item	Art.-No.	Max. recom. static load (centr. tension)	
		$N_{recom.}$ [kN]	
PV M 6	020947	0.30	
PV M 8	079678	2.00	

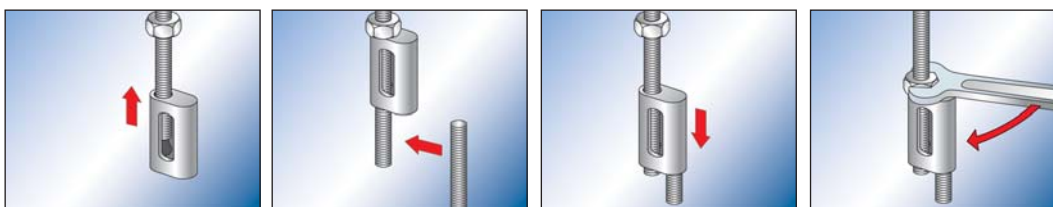



APPLICATIONS

- Fastening element for the installation of two parallel pipelines with just one fastening point

ADVANTAGES/BENEFITS

- The double connector plate design saves a fastening point for the fastening of two pipelines.
- The two-part double connector plate DPF is suitable for variable pipe spacing.
- The base plate's long slots allow the double connector plate to be easily aligned.
- The rounded design of the connector plate is ideal for a visual installation.

PROPERTIES

- Material DPP:** DC04 (material no. 1.0338) acc. to DIN EN 10130
- Material DPF:** DC01 (material no. 1.0330) acc. to DIN EN 10130
- Zinc plating:** electro zinc-plated, min. 5 µm

TECHNICAL DATA

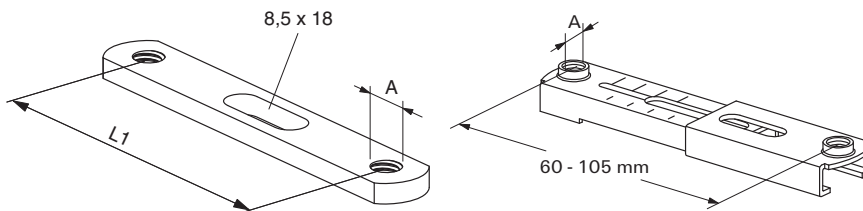

DPP

DPF

Item	Art.-No.	Length	Thread	Sales unit
		L1 [mm]	A	[pcs]
DPP 65	079702	65	M 8	50
DPP 85	079703	85	M 8	50
DPP 105	079704	105	M 8	50
DPF 60 - 105	024648	60 - 105	M 8	50

LOADS

Item	Art.-No.	Max. recom. static load (centr. tension)	
		$N_{recom.}$ [kN]	
DPP 65	079702	1.50	
DPP 85	079703	1.00	
DPP 105	079704	0.75	
DPF 60 - 105	024648	1,5 - 0,5	

Bolt connector SBB

TECHNICAL DATA



Bolt connector **SBB**

PROPERTIES

- **Material:** steel S235 JR (material no.: 1.0037) acc. to DIN EN 10025
- **Zinc plating:** electro zinc-plated, min. 8 µm

Item	Art.-No.	Length l [mm]	Thread A	Sales unit [pcs]
SBB 35	079705	35	M 8	100
SBB 45	079706	45	M 8	100
SBB 55	079707	55	M 8	100

Installation tool for stud screw HED

TECHNICAL DATA



Installation tool **HED**

APPLICATIONS

- Tool for installing stud screws STST
- 4 thread sizes in 1 tool

Item	Art.-No.	Thread M	Sales unit [pcs]
HED	079831	M6, M8, M10, M12	1

Turnbuckle SPS, Bolt left-hand/right-hand BLR

TECHNICAL DATA



Turnbuckle **SPS**, Bolt left-hand/right-hand **BLR**

PROPERTIES

- **Material SPS:** steel ≥ 330 N/mm² acc. to DIN 1480
- **Material BLR:** steel acc. to DIN 976, resistance 4.6
- **Zinc plating:** electro zinc-plated, min. 5 µm

Item	Art.-No.	Length l [mm]	Thread M	Max. recom. static load (centr. tension) N _{recom.} [kN]	Sales unit [pcs]
SPS M 10	537211	125	M 10	10.00	25
BLR 100 M10	537210	100	M 10	10.00	25
SPS M 12	064090	125	M 12	15.00	25
BLR 100 M12	064091	100	M 12	15.00	25

Hexagonal screw SKS

TECHNICAL DATA

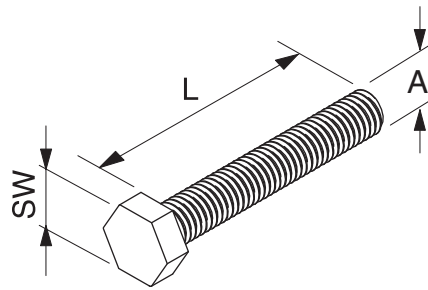

PROPERTIES

- **Material:** steel acc. to DIN-EN-ISO 4017, steel 8.8
- **Zinc plating:** electro zinc-plated, min. 3 µm

Hexagonal bolt **SKS**

Item	Art.-No.	Length	Thread	Width across nut	Sales unit
		L [mm]	A1	SW [mm]	[pcs]
SKS 6 x 20	079711	20	M 6	10	100
SKS 8 x 16	079415	16	M 8	13	100
SKS 8 x 30	079713	30	M 8	13	100
SKS 8 x 45	079714	45	M 8	13	100
SKS 8 x 55	079715	55	M 8	13	100
SKS 8 x 100	079827	100	M 8	13	100
SKS 10 x 20	079416	20	M 10	17	100
SKS 10 x 30	079417	30	M 10	17	100
SKS 10 x 55	079721	55	M 10	17	100
SKS 10 x 65	535537	65	M 10	17	50
SKS 10 x 85	505552	85	M 10	17	100
SKS 12 x 25	535538	25	M 12	19	100
SKS 12 x 65	535539	65	M 12	19	50
SKS 12 x 85	505553	85	M 12	19	100

Washer U

TECHNICAL DATA



PROPERTIES

- **Material:** steel acc. to DIN 10139
- **Zinc plating:** electro zinc-plated, min. 3 µm

Washer **U**

Item	Art.-No.	Thickness	Hole diameter	External-Ø	Sales unit
		S [mm]	D [mm]	d [mm]	[pcs]
U 8 x 17	091477	1.6	8.4	17	100
U 8 x 28	079725	2	8.4	28	100
U 8 x 40	079729	3	8.4	40	100
U 10 x 21	091478	2	10.5	21	100
U 10 x 28	079726	2	10.5	28	100
U 10 x 40	079730	3	10.5	40	100
U 12 x 24	557301	2.5	12.5	24	100
U 12 x 40	024649	3	12.5	40	100
U 16 x 30	557303	3	16.5	30	50
U 16 x 40	535540	3	17	40	50

Hexagonal nut MU

TECHNICAL DATA

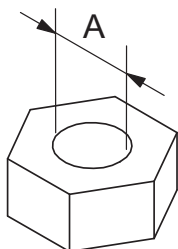

PROPERTIES

- **Zinc plating:** electro zinc-plated, 3 - 8 μm
- **Quality:** acc. DIN 934, resistance class 8

Hexagonal nut **MU**

Item	Art.-No.	Thread	Width across nut	Sales unit
		A	\circ SW [mm]	[pcs]
MU M 6	079733	M 6	10	100
MU M 8	079734	M 8	13	100
MU M 10	079735	M 10	17	100
MU M 12	024650	M 12	19	100
MU M 16	557297	M 16	24	50
MU M 20	535532	M 20	30	15
MU M 24	535534	M 24	36	15

Hexagonal connector VM

TECHNICAL DATA

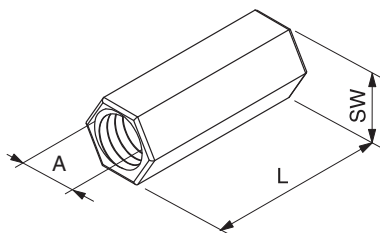

PROPERTIES

- **Material:** SAE 1008 (material no. 1.0213) acc. to DIN EN 10263-2
- **Zinc plating:** electro zinc-plated, 3 - 8 μm

Hexagonal connector **VM**

Item	Art.-No.	Length	Thread	Width across nut	Sales unit
		L [mm]	A1	[mm]	[pcs]
VM M 6	014319	25	M 6	10	100
VM M 8	079690	30	M 8	11	100
VM M 10	079691	30	M 10	13	100
VM M 12	020971	40	M 12	17	100
VM M 16	508833	40	M 16	24	50

Eyebolt AG

TECHNICAL DATA



PROPERTIES

- **Material:** steel S235 JR (material no.: 1.0037) acc. to DIN EN 10025
- **Zinc plating:** electro zinc-plated, 3 - 8 μm

Eyebolt **AG**

Item	Art.-No.	Length	Thread	Eye \emptyset	Max. recom. static load (centr. tension)	Sales unit
		l [mm]	A	D [mm]	$N_{\text{recom.}}$ [kN]	[pcs]
AG 8 x 25	079696	25	M 8	8,5	5.00	100
AG 10 x 25	079697	25	M 10	12,0	8.00	100

Thread hanger RAH

TECHNICAL DATA



Thread hanger RAH

PROPERTIES

- **Material:** annealed cast iron GJMB 350-10 acc. to DIN 1562
- **Zinc plating:** electro zinc-plated, 3 - 8 µm

Item	Art.-No.	Thread A	Eye Ø D [mm]	Max. recom. static load (centr. tension) N _{recom.} [kN]	Sales unit [pcs]
RAH M 8	079698	M 8	12,0	4.00	50
RAH M 10	079699	M 10	12,0	4.00	50

Reduction piece RD

TECHNICAL DATA



Reduction piece RD

PROPERTIES

- **Material:** 11 SMnPb30 (material no. 1.0718) acc. to DIN EN 10087
- **Zinc plating:** electro zinc-plated, 3 - 8 µm

Item		Internal thread A1	External thread A2	Length l [mm]	Width across nut ○SW [mm]	Sales unit [pcs]
RD M 6 / M 8	079694	M 6	M 8	20	9	100
RD M 8 / M 6	020936	M 8	M 6	19	11	100
RD M 10 / M 8	079692	M 10	M 8	23	13	50
RD M 12 / M 10	079693	M 12	M 10	25	17	100
RD M 12 / M 16	504397	M 12	M 16	32	19	50
RD M 16 / M 12	504399	M 16	M 12	32	24	50
RD 1/2" / M10	079695	1/2"	M 10	29	24	10
RD M 16 / M 12 long	538080	M 16	M 12	46.5	24	10
RD 1/2" / M10 long	537215	1/2"	M 10	39	24	10
RD 3/4" / M 12 long	537213	3/4"	M 12	46.5	30	10
RD 3/4" / M 16 long	537214	3/4"	M 16	46.5	30	10

Reduction socket RDM and GRD

TECHNICAL DATA



Reduction socket **RDM**



Reduction socket **GRD**

PROPERTIES

- **Material RDM:** SAE 1008
- **Material GRD:** 11SMnPb30 (material no. 1.0718) acc. to DIN EN 10277
- **Zinc plating:** electro zinc-plated, 3 - 8 µm

Item	Art.-No.	Thread		Sales unit [pcs]
		A	A2	
RDM M 10 / M 8	079413	M 8	M 10	50
RDM M 12 / M 10	079414	M 10	M 12	100
GRD 1/2" / M 10	077609	1/2"	M 10	100
GRD 1/2" / M 12	077608	1/2"	M 12	100
GRD 3/4" / M 10	077607	3/4"	M 10	100
GRD 3/4" / M 12	077606	3/4"	M 12	100

Flat eye screw LLS

TECHNICAL DATA



Flat eye screw **LLS**

PROPERTIES

- **Material:** steel S235 JR (material no.: 1.0037) acc. to DIN EN 10025
- **Zinc plating:** electro zinc-plated, 3 - 8 µm

Item	Art.-No.	Length		Thread	Eye Ø	Sales unit [pcs]
		L	[mm]			
LLS 6 x 50	079700	50	6	6	8,5	100
LLS 8 x 50	079701	50	8	8	10,5	100



APPLICATIONS

- Tear-proof textile tape for simple and load-bearing installation
- Fixing to concrete using the fischer impact nail ED

ADVANTAGES/BENEFITS

- Pipe fastening using textile tape allows cheap and simple installation.
- The textile tape roll allows the correct tape length to be chosen to suit the diameter in question.
- Hangings with textile tape are a fast solution for temporary fixings.

PROPERTIES

- **Material:** polypropylene

TECHNICAL DATA

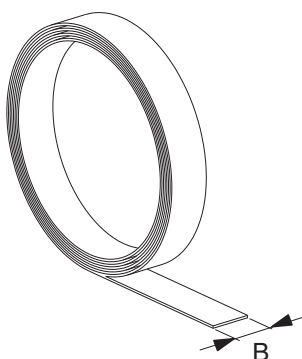

Item	Art.-No.	Total length [mm]	Width [mm]	Thickness [mm]	Sales unit [pcs]
GWB	020959	10.000	15	1.1	10

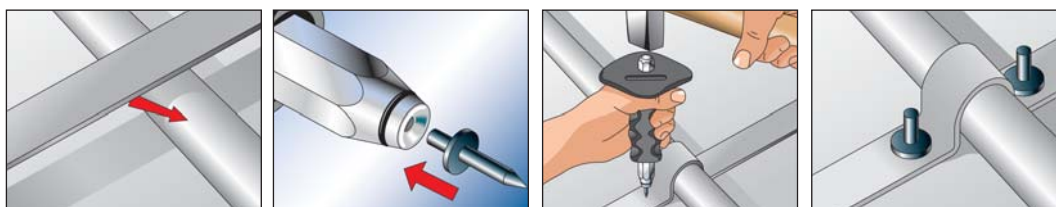



APPLICATIONS

- Steel tape with stamped holes for simple installation; available zinc-plated LBV or plastic-covered LKB
- The fischer nail anchor FNA II is suitable for ceiling fixing in concrete
- Use fischer thread hanger RAH for fastening to threaded rods

ADVANTAGES/BENEFITS

- The perforated tape's material thickness and plastic covering allows the tapes to be easily cut to size using metal shears.
- The perforated tape's hole geometry enables concrete fixing using the fischer impact nail ED.

PROPERTIES

- **Material:** steel DX51D+Z (material no. 1.0226) acc. to DIN EN 10327
- **Zinc plating:** electro zinc-plated, min. 7 µm
- **Protective coating LBK:** PE

TECHNICAL DATA

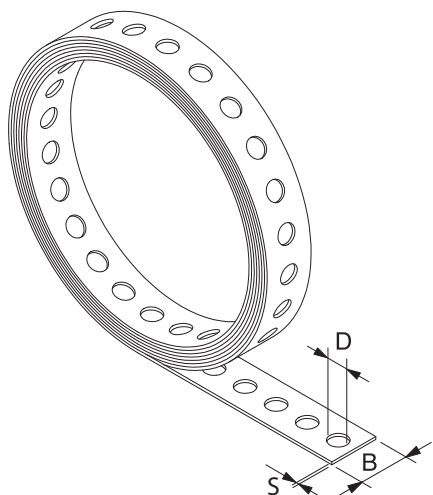

Item	Art.-No.	Total length	Width B	Thickness	Eye Ø	Sales unit
		l [mm]	B [mm]	S [mm]	D [mm]	
LBV 12	079549	10.000	12	0.75	5	10
LBV 17	079550	10.000	17	0.75	6,5	10
LBV 25	079551	10.000	25	0.88	8,5	8
LBK 14	079553	10.000	14	2.6	5	10
LBK 19	079554	10.000	19	2.4	6,5	8
LBK 27	079555	10.000	27	2.4	8,5	5

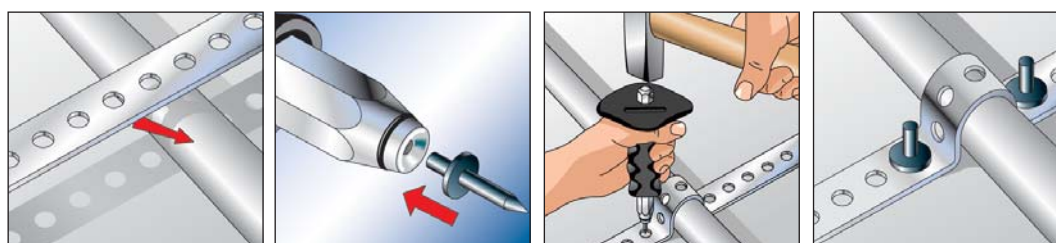

Fixing in concrete without pre-drilling



Fixing armoured conduits



Fixing perforated tapes

BUILDING MATERIALS

- Concrete

ADVANTAGES

- The stable impact nail ED can be set in concrete with the impact nail setting tool SZE without pre-drilling. This allows for a fast installation.
- The setting tool SZE impact protection provides the best protection for your hand, thus ensuring a safe installation.

APPLICATIONS

For fixing of:

- Conduit clips such as BSM, BSMD, BSMZ
- Perforated band such as LBK, LBV

FUNCTIONING

- The impact nail ED is set in the setting tool SZE.
- The bracket in the setting tool holds the nail securely in place during the installation procedure.
- The nail can then be directly hit into the concrete which should not be older than 6 months.

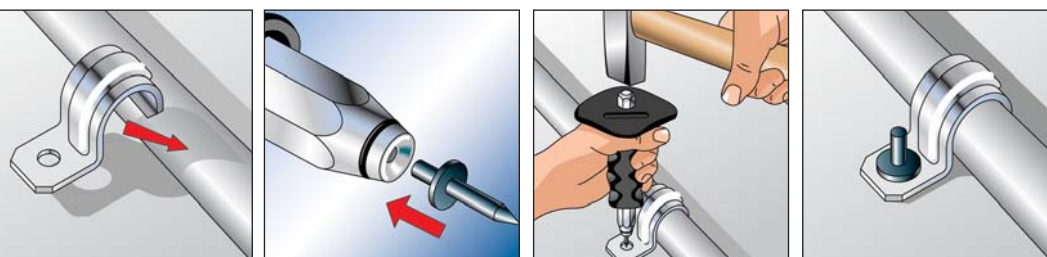

TECHNICAL DATA



Impact nail **ED**

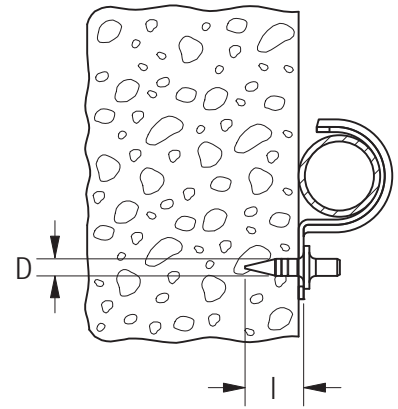

Item	Art.-No.	Length	Diameter	Sales unit				
		l [mm]	d [mm]	[pcs]				
ED 15	048212	15	4.0	200				
ED 18	079815	18	4.0	200				
ED 22	014570	22	4.0	200				

TECHNICAL DATA



Impact nail setting tool **SZE**

Toolset for **SZE**

Item	Art.-No.	Sales unit						
		[pcs]						
SZE	079820	1						
Toolset for SZE	043365	4						

Accessories

∞



9

Installation system FUS hot-dip galvanised

	page		page
Channels		Construction elements	
Channel FUS hdg.	212	Saddle flange SF hdg.	225
Cantilever		Mounting bracket UWS hdg.	226
Cantilever arm FCA hdg.	217	Angle bracket WK hdg.	227
Large cantilever arm FCAM hdg.	220	Bracket FAF hdg.	235
Cover cap FEC	221	Flanges FUF hdg.	236
Connectors		Bracket FFF hdg.	233
Connector FCN Clix P hdg. / FCN Clix M hdg.	222	Variable bracket VB hdg.	229
Channel washer HK 41 hdg.	224	Threaded rod bracket FSB 45° hdg.	230
		Beam clamp TKR hdg.	231
		Channel connector FUF OC hdg.	216

The universal and complete mounting channel system for a wide range of applications



3D-frame constructions



Solid frame construction

9

APPLICATIONS

- Creation of secure, horizontal and vertical installations
- Fast and efficient fixing of pipelines and supporting structures
- For indoor and outdoor applications and in environments with high stress to components due to corrosion

ADVANTAGES/BENEFITS

- The fire inspection report in line with MLAR/EN13501 guarantees independently tested functional safety.
- The basic channel geometry allows for the usage of the complete extensive range of accessories.
- The stamped teeth in the channel gives the sliding nuts a secure hold for high shear loads, e.g. for vertical installation.
- Different channel wall thicknesses allow for economical choices for installation.
- The scale on the mounting channels simplifies the cutting and positioning of the fixtures during installation.
- The surface coating creates a high corrosion protection against environmental influences like humidity, water, saltwater or other corrosive substances.

CERTIFICATES



PROPERTIES

- **Material:** steel S235 JR (material no.: 1.0037) acc. to DIN EN 10025
- **Zinc plating:** hot-dip galvanised, min. 45 µm, acc. to DIN EN ISO 1461

SEE ALSO



FCN Clix P/M hdg
see page 222



EMS
see page 184



FTC-ZS
see page 331

TECHNICAL DATA

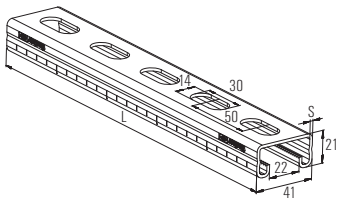

FUS 21 hdg.

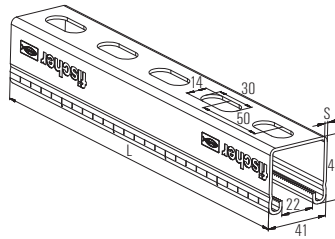

FUS 41 hdg.

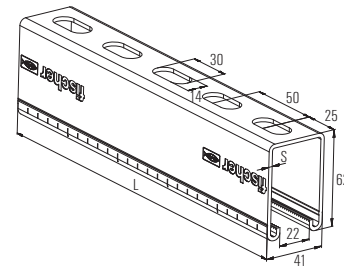

FUS 62 hdg.

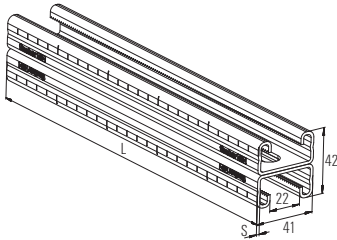

FUS 21D hdg.

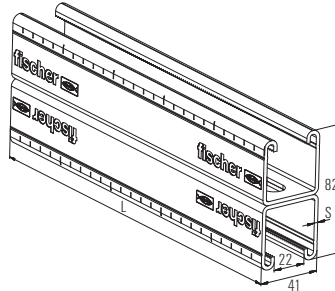

FUS 41D hdg.

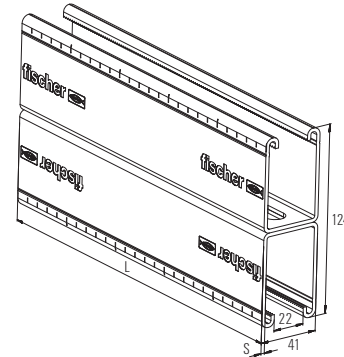

FUS D62 hdg.

Item	Art.-No.	Fire test report	Length		Thickness		Sales unit
			L [mm]	S [mm]	S [mm]	[pcs]	
FUS 21/2,0 - 3 m hdg.	537653	—	3000	2.0	2.0	1	
FUS 41/2,0 - 3 m hdg.	517426	—	3000	2.0	2.0	1	
FUS 41/2,0 - 6 m hdg.	537656	—	6000	2.0	2.0	1	
FUS 41/2,5 - 6 m hdg.	537658	X	6000	2.5	2.5	1	
FUS 62/2,5 - 3 m hdg.	517427	X	3000	2.5	2.5	1	
FUS 62/2,5 - 6 m hdg.	517428	X	6000	2.5	2.5	1	
FUS 21D/2,0 - 3 m hdg.	537659	—	3000	2.0	2.0	1	
FUS 21D/2,0 - 6 m hdg.	537661	—	6000	2.0	2.0	1	
FUS 41D/2,5 - 6 m hdg.	537662	—	6000	2.5	2.5	1	
FUS 62D/2,5 - 6 m hdg.	537663	—	6000	2.5	2.5	1	

LOADS

Item	Art.-No.	Profil weight [kg/m]	Profile cross section [cm ²]	Moment of inertia I _y [cm ⁴]	Moment of inertia I _z [cm ⁴]	Section modulus W _y [cm ³]	Section modulus W _z [cm ³]	Max. recommended static load for 1m length	Max. recommended static load for 2m length	Max. recommended static load for 3m length
								F _{rec} [kN]	F _{rec} [kN]	F _{rec} [kN]
FUS 21/2,0 - 3 m hdg.	537653	1.44	1.72	0.97	4.66	0.89	2.27	0.49	0.12	0.05
FUS 41/2,0 - 3 m hdg.	517426	2.06	2.52	5.33	7.69	2.58	3.75	1.94	0.67	0.30
FUS 41/2,0 - 6 m hdg.	537656	2.06	2.52	5.33	7.69	2.58	3.75	1.94	0.67	0.30
FUS 41/2,5 - 6 m hdg.	537658	2.45	3.00	6.00	8.99	2.85	4.38	2.14	0.76	0.34
FUS 62/2,5 - 3 m hdg.	517427	3.27	4.05	17.70	12.90	5.62	6.29	4.22	2.10	0.99
FUS 62/2,5 - 6 m hdg.	517428	3.27	4.05	17.70	12.90	5.62	6.29	4.22	2.10	0.99
FUS 21D/2,0 - 3 m hdg.	537659	2.87	3.44	5.49	9.31	2.61	4.54	1.96	0.69	0.31
FUS 21D/2,0 - 6 m hdg.	537661	2.87	3.44	5.49	9.31	2.61	4.54	1.96	0.69	0.31
FUS 41D/2,5 - 6 m hdg.	537662	4.89	6.00	35.01	17.90	8.76	8.78	6.58	3.28	1.96
FUS 62D/2,5 - 6 m hdg.	537663	6.55	8.09	111.00	25.80	17.90	12.58	13.45	6.72	4.47

FUS 21 / 2.0

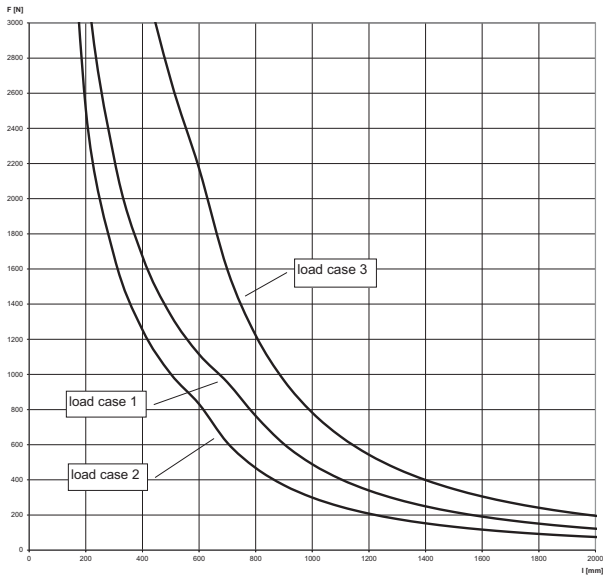

FUS 21 / 2.5

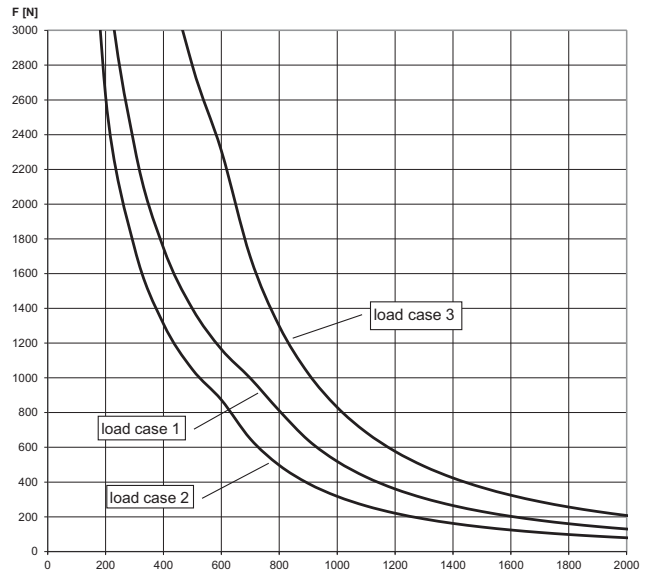

For the load curves, the permissible steel strain $\delta_{adm.} = 188$ N/mm and the maximum deflection under load $L/200$ are not exceeded. Fixings and screw fastenings must be calculated accordingly. The increased yield strength is calculated according DIN EN 1993-1-3:2010-12, sec. 3.2.2.

FUS 41 / 2.0

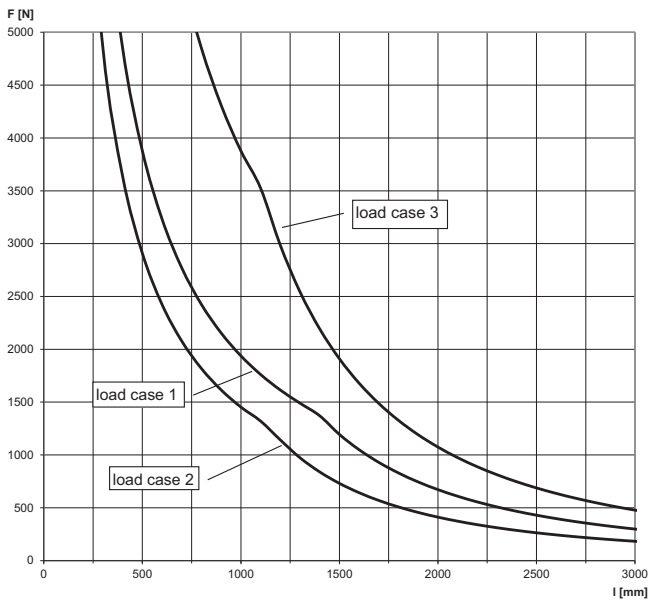

FUS 41 / 2.5

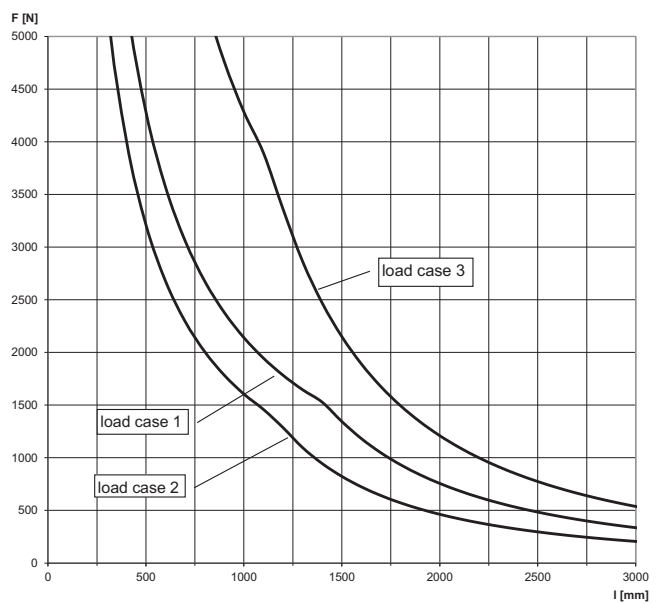

For the load curves, the permissible steel strain $\delta_{adm.} = 188$ N/mm and the maximum deflection under load $L/200$ are not exceeded. Fixings and screw fastenings must be calculated accordingly. The increased yield strength is calculated according DIN EN 1993-1-3:2010-12, sec. 3.2.2.

FUS 62 / 2.5

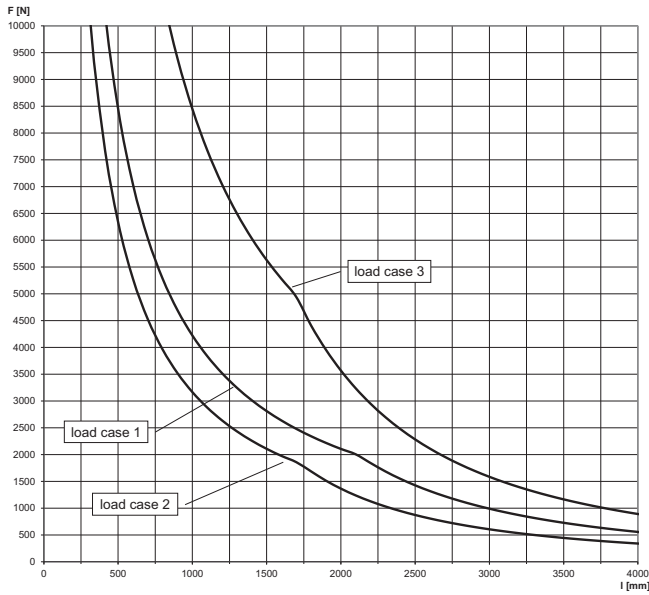

FUS 21D / 2.0

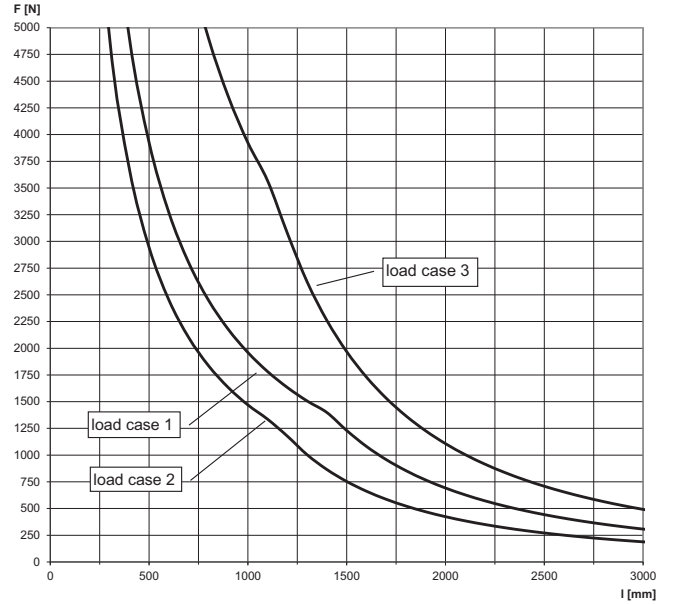

For the load curves, the permissible steel strain $\delta_{adm.} = 188$ N/mm and the maximum deflection under load $L/200$ are not exceeded. Fixings and screw fastenings must be calculated accordingly. The increased yield strength is calculated according DIN EN 1993-1-3:2010-12, sec. 3.2.2.

FUS 41D / 2.5

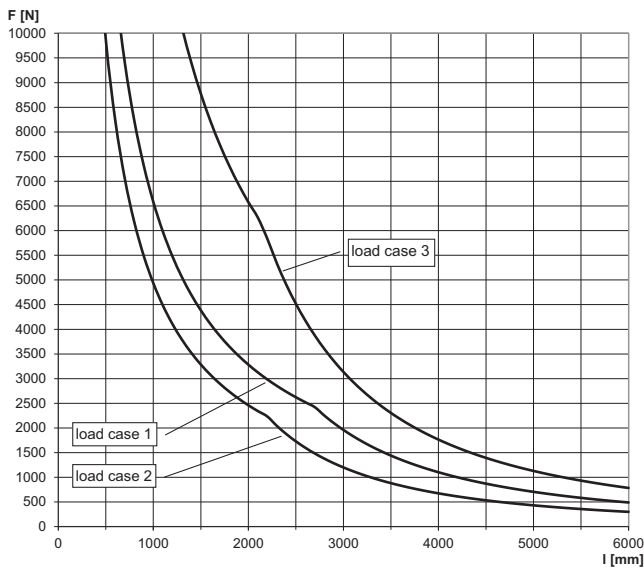

FUS 62D / 2.5

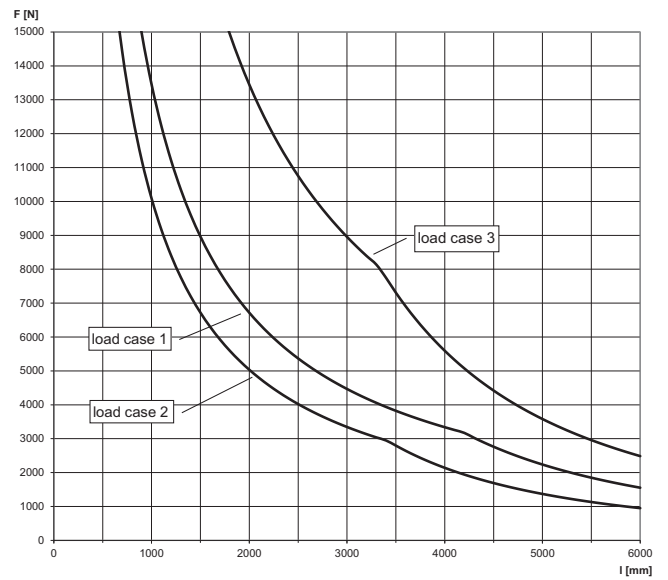

For the load curves, the permissible steel strain $\delta_{adm.} = 188$ N/mm and the maximum deflection under load $L/200$ are not exceeded. Fixings and screw fastenings must be calculated accordingly. The increased yield strength is calculated according DIN EN 1993-1-3:2010-12, sec. 3.2.2.

Construction element - Channel connector FUF OC hdg.



APPLICATIONS

- Connection and alignment of the channels
- For indoor and outdoor applications and in environments with high stress to components due to corrosion

ADVANTAGES/BENEFITS

- The FUF OC connector in combination with FCN Clix P allows a simple and time-saving installation.
- The surface coating creates a high corrosion protection against environmental influences like humidity, water, saltwater or other corrosive substances.

PROPERTIES

- **Material FUF OC:** steel S235 JR (material no. 1.0037) acc. to DIN EN 10025
- **Zinc plating FUF OC:** hot-dip galvanised, min. 45 µm, acc. to DIN EN ISO 1461

TECHNICAL DATA

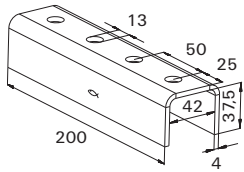

FUF OC 41 hdg.

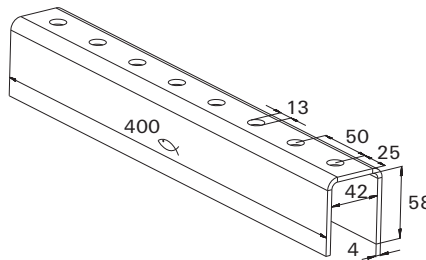

FUF OC 62 hdg.

Item	Art.-No.	Length [mm]	Sales unit [pcs]		
FUF OC 41 hdg.	517415	200	20		
FUF OC 62 hdg.	537591	400	10		

Installation system FUS hot-dip galvanised

9

Hot-dip galvanised FUS profiles with welded base plate for direct mounting on the base material



Refrigerant pipe clamp on sliding element



Heavy pipe on cantilever

APPLICATIONS

- Quick and easy installation of pipe-lines, for example, along the wall
- For indoor and outdoor applications and in environments with high stress to components due to corrosion

ADVANTAGES/BENEFITS

- The fire inspection report in line with MLAR/EN 13501 guarantees independently tested functional safety.
- The graduated range of lengths allows for an ideal adaptation to the application.
- The arms solid base plate offers a secure hold for load-bearing construction.
- The base plate's long slots, which are at 90° to one another, allow the arm to be easily aligned.
- The stamped teeth in the channel give the sliding nuts a secure hold for high shear loads, e.g. for vertical installation.
- The surface coating creates a high corrosion protection against environmental influences like humidity, water, saltwater or other corrosive substances.

CERTIFICATES



PROPERTIES

- **Material:** steel S235 JR (material no. 10037) acc. to DIN EN 10025
- **Zinc plating:** hot-dip galvanised, min. 45 µm, acc. to DIN EN ISO 1461

TECHNICAL DATA

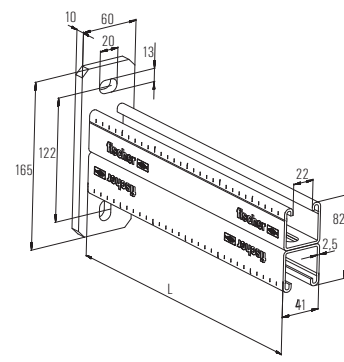
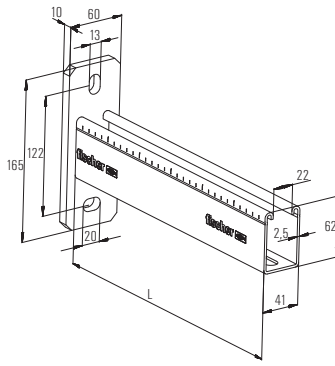
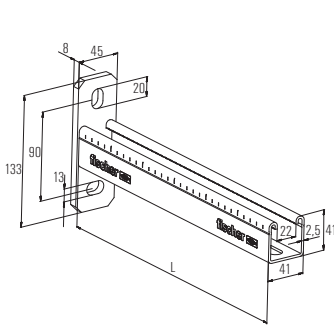

FCA 41 hdg.

FCA 62 hdg.

FCA 41D hdg.

Item	Art.-No.	Fire test report	Profile	Length	Sales unit
				L [mm]	
FCA 41 - 300 hdg.	517411	X	41/2,5	300	1
FCA 41 - 450 hdg.	517412	X	41/2,5	450	1
FCA 41 - 600 hdg.	517413	X	41/2,5	600	1
FCA 41 - 750 hdg.	517414	X	41/2,5	750	1
FCA 62 - 1000 hdg.	538015	X	62/2,5	1000	1
FCA 41D - 750 hdg.	538016	—	41D/2,5	750	1
FCA 41D - 1000 hdg.	538017	—	41D/2,5	1000	1

LOADS

Item	Art.-No.	Max. recommended static load load case 1	Max. recommended static load load case 2	Max. recommended static load load case 3
		F_{rec} [kN]	F_{rec} [kN]	F_{rec} [kN]
FCA 41 - 300 hdg.	517411	1.8	0.9	1.8
FCA 41 - 450 hdg.	517412	1.2	0.6	1.2
FCA 41 - 600 hdg.	517413	0.9	0.45	0.9
FCA 41 - 750 hdg.	517414	0.72	0.36	0.72
FCA 62 - 1000 hdg.	538015	1.25	0.62	1.25
FCA 41D - 750 hdg.	538016	2.5	1.25	2.5
FCA 41D - 1000 hdg.	538017	1.9	0.93	1.9

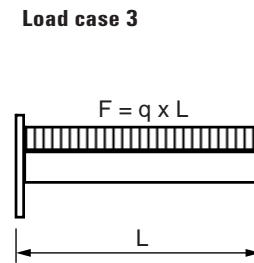
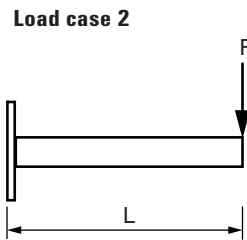
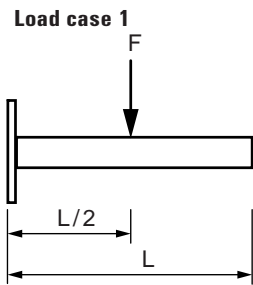

FCA 41 HDG.

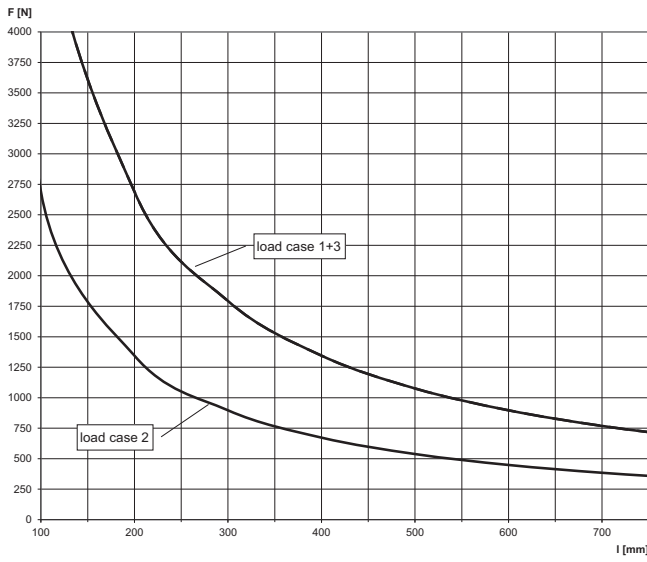

For the load curves, the permissible steel strain $\delta_{adm.} = 160$ N/mm and the maximum deflection under load $L/150$ are not exceeded. Load capacity for console under consideration of the capacity of base plate. Fixings and screw fastenings must be calculated accordingly.

FCA 62 HDG.

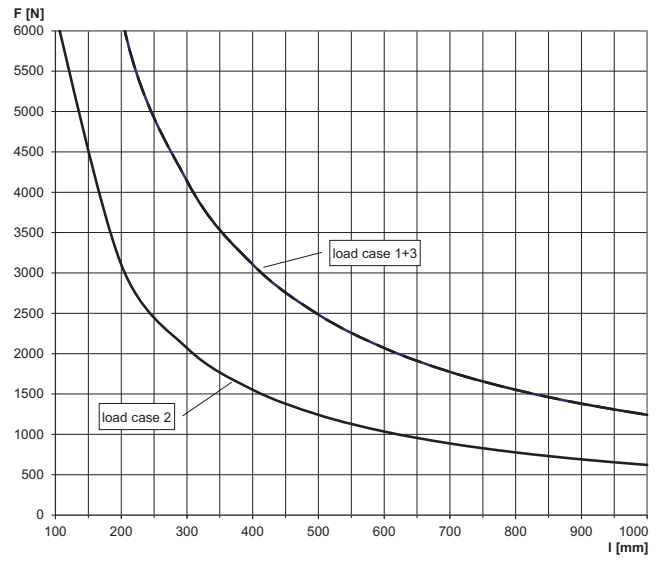

FCA 41 D HDG.

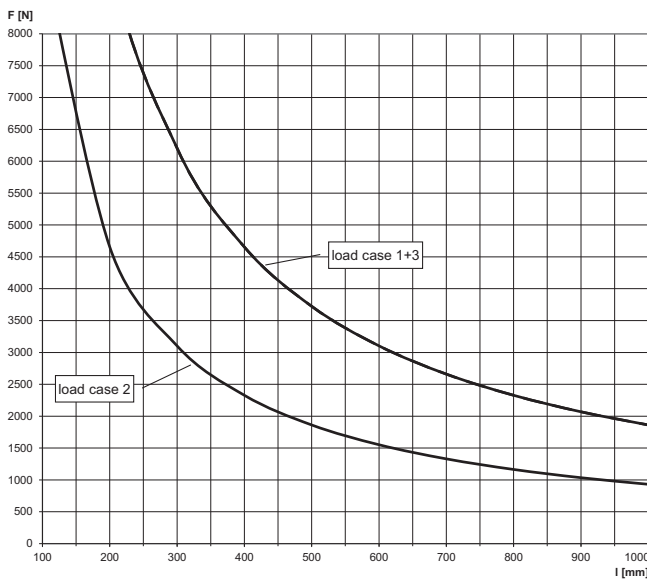

For the load curves, the permissible steel strain $\delta_{adm.} = 160$ N/mm and the maximum deflection under load $L/150$ are not exceeded. Load capacity for console under consideration of the capacity of base plate. Fixings and screw fastenings must be calculated accordingly.

The large cantilever arm for heavy loads



Upright pipe on cantilever arm



Sliding element on cantilever

APPLICATIONS

- Quick and easy installation of pipelines with heavy loads
- For indoor and outdoor applications and in environments with high stress to components due to corrosion

ADVANTAGES/BENEFITS

- The robust construction, consisting of a basic and a support profile, allows the bearing of heavy loads.
- The graduated range of lengths allows an ideal adaptation to the application.
- The base plate's long slots, which are at 90° to one another, allow the arm to be easily aligned.
- The stamped teeth in the channel give the sliding nuts a secure hold for high shear loads, e.g. for vertical installation.
- The surface coating creates a high corrosion protection against environmental influences like humidity, water, saltwater or other corrosive substances.

PROPERTIES

- **Material:** steel S235 JR (material no.10037) acc. to DIN EN 10025
- **Zinc plating:** hot-dip galvanised, min. 45 µm, acc. to DIN EN ISO 1461

TECHNICAL DATA

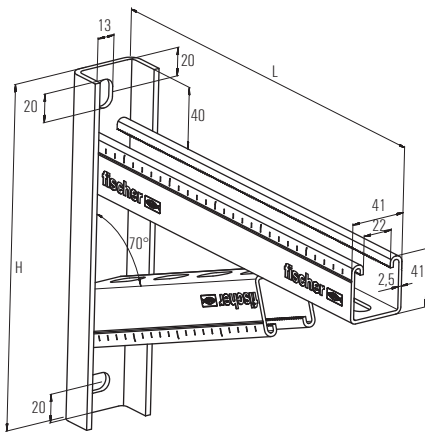

Item	Art.-No.	Length	Height H	Sales unit
		L [mm]	H [mm]	
FCAM 300 hdg.	538018	300	246	1
FCAM 400 hdg.	538019	400	270	1
FCAM 500 hdg.	538020	500	284	1
FCAM 600 hdg.	538021	600	319	1
FCAM 700 hdg.	538022	700	343	1

Installation system FUS hot-dip galvanised 9

LOADS

Item	Art.-No.	Max. recommended static load load case 1 F_{rec} [kN]	Max. recommended static load load case 2 F_{rec} [kN]	Max. recommended static load load case 3 F_{rec} [kN]
FCAM 300 hdg.	538018	7.0	3.7	7.0
FCAM 400 hdg.	538019	7.5	2.8	7.5
FCAM 500 hdg.	538020	6.5	2.3	6.5
FCAM 600 hdg.	538021	6.0	1.9	6.0
FCAM 700 hdg.	538022	5.5	1.3	5.5

Load case 1

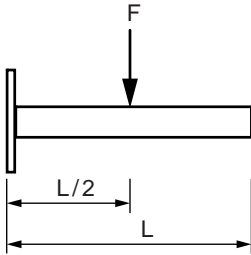

Load case 2

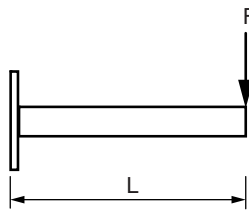

Load case 3

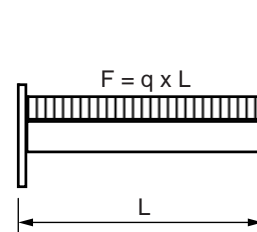

COVER CAP FEC



FEC 21 B

FEC 41 B

FEC 62 B

Item	Art.-No.	For profile	Material	Sales unit [pcs]
FEC 21 B	077357	41/21	polyethylene, black	100
FEC 41 B	077355	41/41	polyethylene, black	100
FEC 62 B	505551	41/62	polyethylene, black	100

Channel nut for quick and easy fixing in FUS profiles



APPLICATIONS

- Connection of FUS rails and fixtures
- Connection of pipe clamps with a threaded rod
- For indoor and outdoor applications and in environments with high stress to components due to corrosion

ADVANTAGES/BENEFITS

- The sliding nut design allows for quick and easy setting in the channel.
- The spring effect of the plastic clasp guarantees simple and precise positioning in the channel.
- The FCN Clix P's flat plastic mounting with wings offers a good hold and allows the fixtures to be conveniently mounted.
- The teeth on the sliding nut provide a secure hold in the FUS channel.
- Installation by rotating 90° enables post-installation in installed channel.
- The surface coating creates a high corrosion protection against environmental influences like humidity, water, saltwater or other corrosive substances.

CERTIFICATES



PROPERTIES

- **Material:** steel S235 JR (material no. 1.0037) acc. to DIN EN 10025, plastic Nylon PA6
- **Zinc plating:** hot-dip galvanised, min. 40 µm, acc. to DIN EN ISO 146 1



TECHNICAL DATA

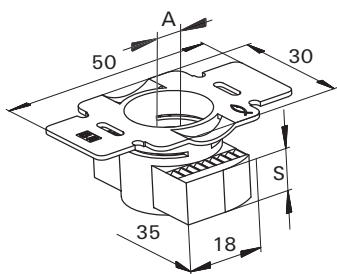

FCN Clix P hdg.

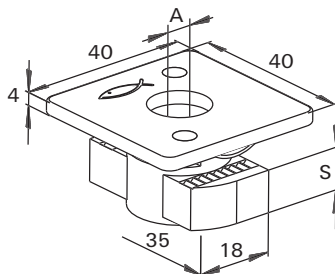

FCN Clix M hdg.

Item	Art.-No.	Fire test report	Thread	Thickness	Sales unit
			A	S [mm]	[pcs]
FCN Clix P 8 hdg.	538106	–	M 8	6	100
FCN Clix P 10 hdg.	538107	X	M 10	8	100
FCN Clix P 12 hdg.	517420	X	M 12	9.5	100
FCN Clix M 8 hdg.	538108	–	M 8	6	100
FCN Clix M 10 hdg.	538109	X	M 10	8	100
FCN Clix M 12 hdg.	538110	X	M 12	9.5	100

9

LOADS

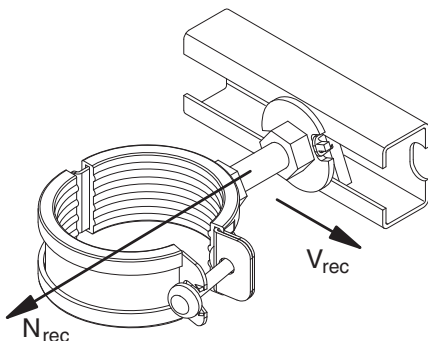

Item	Art.-No.	Max. recommended tension load for FUS 2,0mm	Max. recommended tension load for FUS 2,5mm	Max. recommended shear load	Tightening torque for screw grade ≥ 8.8	Tightening torque for screw grade ≥ 4.6
		N_{rec} [kN]	N_{rec} [kN]	V_{rec} [kN]	T_{inst} [Nm]	T_{inst} [Nm]
FCN Clix P 8 hdg.	538106	4.0	4.0	1.0	20	–
FCN Clix P 10 hdg.	538107	5.0	8.0	1.5	40	–
FCN Clix P 12 hdg.	517420	5.0	8.0	2.0	50	–
FCN Clix M 8 hdg.	538108	4.0	4.0	–	–	10
FCN Clix M 10 hdg.	538109	5.0	8.0	–	–	15
FCN Clix M 12 hdg.	538110	5.0	8.0	–	–	20

Connector - Channel washer HK hdg.



Lateral pipe mounting at channel



Channel installation at wall

APPLICATIONS

- Channel washer to strengthen the profile
- For indoor and outdoor applications and in environments with high stress to components due to corrosion

ADVANTAGES/BENEFITS

- The U-shape of the channel washer prevents the profile from bending effectively.
- The shape of the channel washer makes push-through installation of channel profiles quick and easy.
- The surface coating creates a high corrosion protection against environmental influences like humidity, water, saltwater or other corrosive substances.

CERTIFICATES



PROPERTIES

- **Material:** steel S235 JR (material no.: 1.0037) acc. to DIN EN 10025
- **Zinc plating:** hot-dip galvanised, min. 45 µm, acc. to DIN EN ISO 1461

TECHNICAL DATA

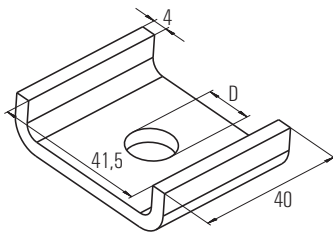

Item	Art.-No.	Fire test report	Hole diameter		Sales unit
			A	[mm]	
HK 41 10,5 hdg.	538113	X	10.5		50
HK 41 12,5 hdg.	538114	X	12.5		50

Installation system FUS hot-dip galvanised 9

Construction element - Saddle flange SF hdg.

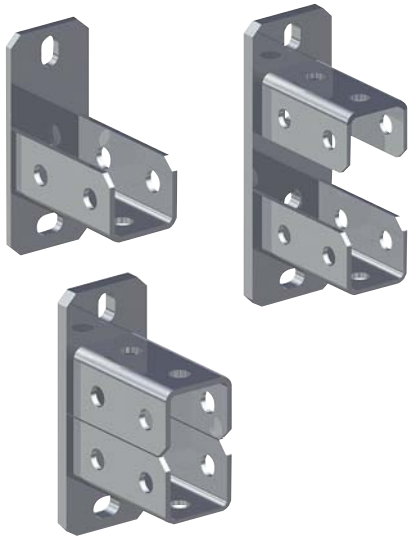

CERTIFICATES



APPLICATIONS

- For solid connections between the channel and building structures
- For indoor and outdoor applications and in environments with high stress to components due to corrosion

ADVANTAGES/BENEFITS

- The perfect-fit saddle of the SF allows simple installation by inserting the mounting channel.
- The saddle flange's stable design offers a secure hold for load-bearing construction.
- The surface coating creates a high corrosion protection against environmental influences like humidity, water, saltwater or other corrosive substances.

PROPERTIES

- Material base plate:** steel DC01 (material no. 1.0330) acc. to DIN EN 10139
- Zinc plating base plate:** hot-dip galvanised, min. $45\ \mu\text{m}$, acc. to DIN EN ISO 1461
- Material U-Profile:** steel S235 JR (material no. 1.0037) nach DIN EN 10025
- Zinc-plating U-Profile:** hot-dip galvanised, min. $45\ \mu\text{m}$, acc. to DIN EN ISO 1461

TECHNICAL DATA

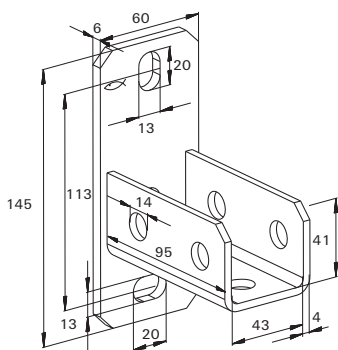

SF L 41 hdg.

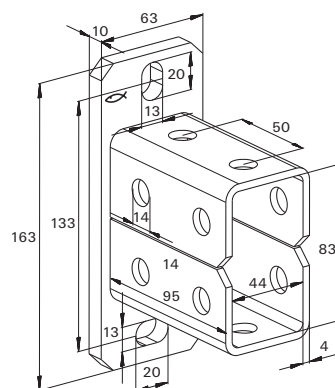

SF L 82 hdg.

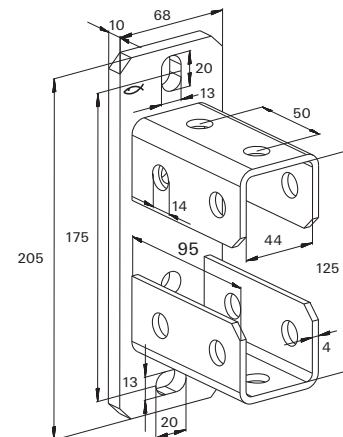

SF L 124 hdg.

Item		Fire test report	For profile	Sales unit	
				[pcs]	
SF L 41 hdg.	517421	X	21, 41, 21D, 62	10	
SF L 82 hdg.	538125	—	41 D	5	
SF L 124 hdg.	538126	—	62 D	5	

LOADS

see Channel nut FCN Clix P hdg.

Construction element - Universal bracket UWS hdg.



3D-frame constructions



Support systems for ventilation

APPLICATIONS

- Universal angle bracket for the reinforcement of supporting structures
- For indoor and outdoor applications and in environments with high stress to components due to corrosion

ADVANTAGES/BENEFITS

- The universal bracket for connecting fischer mounting channels gives a supporting structure great stability and safety (we recommend using in pairs).
- The surface coating creates a high corrosion protection against environmental influences like humidity, water, saltwater or other corrosive substances.

CERTIFICATES

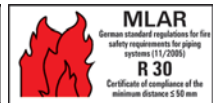

PROPERTIES

- **Material:** steel S235 JR (material no.: 1.0037) acc. to DIN EN 10025
- **Zinc plating:** hot-dip galvanised, min. 45 µm, acc. to DIN EN ISO 1461

TECHNICAL DATA

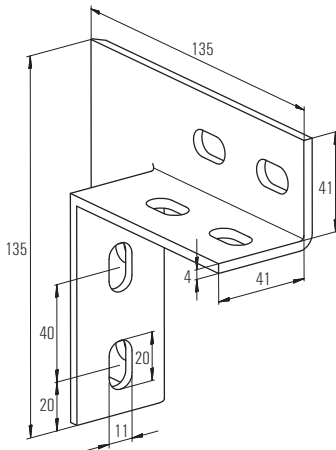

Item	Art.-No.	Fire test report	Sales unit
UWS hdg.	538115	X	[pcs] 10

LOADS

see Channel nut FCN Clix P hdg.

Installation system FUS hot-dip galvanised 9

Construction element - Angle bracket WK hdg.

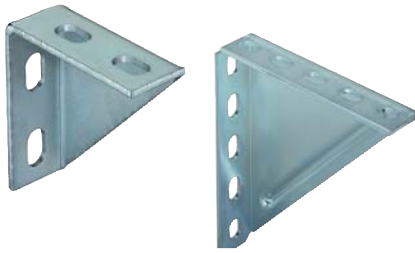

Heavy drainage pipe under angle bracket



Solid frame construction

APPLICATIONS

- Reinforcement and fixing of pipelines and pipe components
- For indoor and outdoor applications and in environments with high stress to components due to corrosion

ADVANTAGES/BENEFITS

- The design of the angle bracket allows the fixing of pipe clamps or mounting channels.
- The stable angle ensures a very high level of stability and safety to the structure.
- The surface coating creates a high corrosion protection against environmental influences like humidity, water, saltwater or other corrosive substances.

PROPERTIES

- **Material:** steel S235JR (material no. 1.0037) acc. to DIN EN 10025
- **Zinc plating:** hot-dip galvanised, min. 45 µm, acc. to DIN EN ISO 1461

TECHNICAL DATA

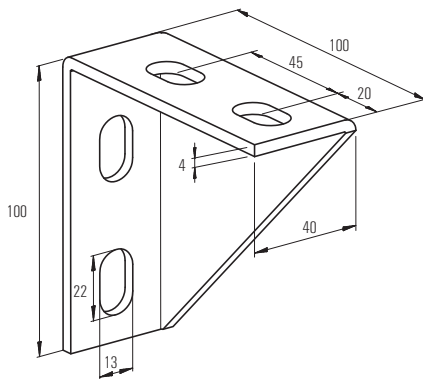

WK 100/100 hdg.

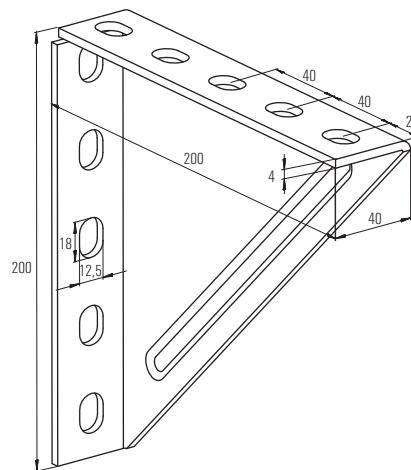

WK 200/200 hdg.

Item	Art.-No.	Sales unit			
			[pcs]		
WK 100/100 hdg.	538117		5		
WK 200/200 hdg.	538118		5		

LOADS

Item	Art.-No.	Max. recommended static load load case 1	Max. recommended static load load case 2
		F_{rec} [kN]	F_{rec} [kN]
WK 100/100 hdg.	538117	—	4.0
WK 200/200 hdg.	538118	4.0	1.8

Load case 1

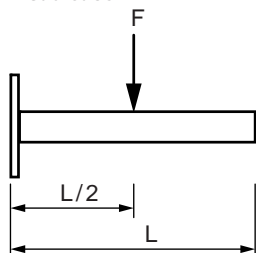

Load case 2

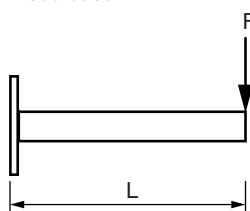

Construction element - Variable bracket VB hdg.



APPLICATIONS

- Variable angular positioning of profile supporting structures
- Installation with FUS channels (from 45° to 90°)
- For indoor and outdoor applications and in environments with high stress to components due to corrosion

ADVANTAGES/BENEFITS

- The design of the channel base VB allows the fixing of mounting channels at any angle between 45°-90°.
- The holes in the base plate allow fixing directly onto a wall or ceiling, or onto a mounting channel.
- The surface coating creates a high corrosion protection against environmental influences like humidity, water, saltwater or other corrosive substances.

PROPERTIES

- **Material:** steel S235JR (material no. 1.0037) acc. to DIN EN 10025
- **Zinc plating:** hot-dip galvanised, min. 35 µm, acc. to DIN EN ISO 1461

TECHNICAL DATA

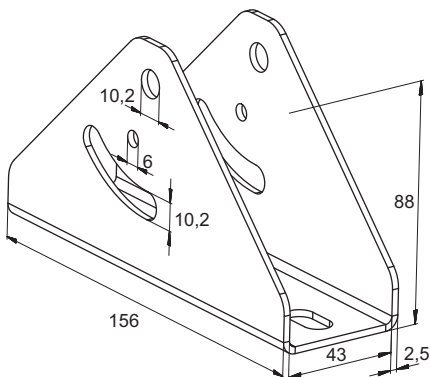

Item	Art.-No.	Slot [mm]	Sales unit [pcs]
VB hdg.	071750	13 x 20	4

LOADS

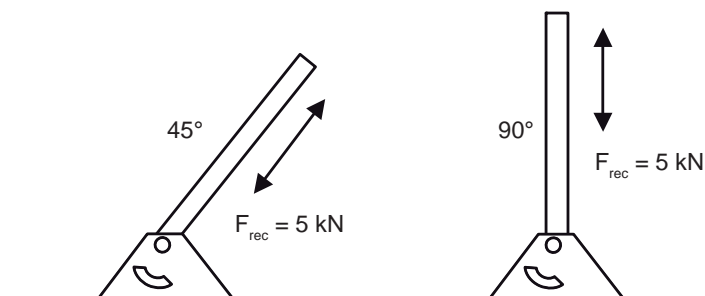

Construction element - Threaded rod bracket FSB 45° hdg.

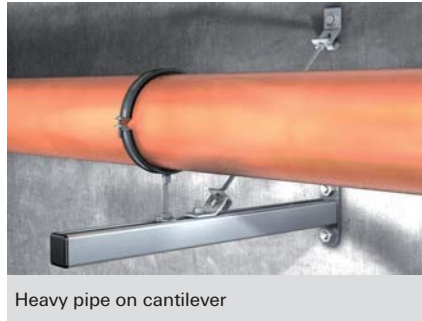

Heavy pipe on cantilever



Bracing for fixpoint

APPLICATIONS

- 45°-element for anchoring with M10 threaded rods
- For indoor and outdoor applications and in environments with high stress to components due to corrosion

ADVANTAGES/BENEFITS

- The anchoring element's socket allows the fast insertion of a pre-mounted M10 threaded rod with nut.
- The hole in the base plate allows the direct fixing onto a wall or ceiling, or onto a mounting channel.
- The surface coating creates a high corrosion protection against environmental influences like humidity, water, saltwater or other corrosive substances.

PROPERTIES

- **Material:** steel S235 JR (material no.: 1.0037) acc. to DIN EN 10025
- **Zinc plating:** hot-dip galvanised, min. 45 µm, acc. to DIN EN ISO 1461

TECHNICAL DATA

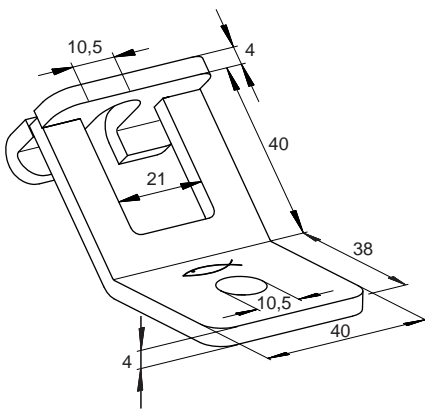

Item	Art.-No.	Sales unit			
		[pcs]			
FSB 45° hdg.	538120	20			

LOADS

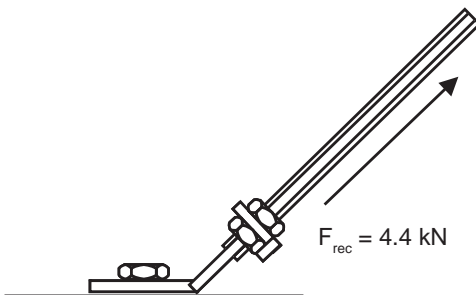

Clamp for fixing of profiles to steel girders



APPLICATIONS

- Fixing to steel girders
- For indoor and outdoor applications and in environments with high stress to components due to corrosion

ADVANTAGES/BENEFITS

- The design of the beam clamp allows fixing without drilling or welding.
- The various lengths of the beam clamp allow the fixing on most standard beams.
- The shape of the beam clamp allows a simple adjustment of the channel connection.
- The surface coating creates a high corrosion protection against environmental influences like humidity, water, saltwater or other corrosive substances.

PROPERTIES

- **Material plate/U-bolt pipe hanger:** steel S235 JR (material no.10037) acc. to DIN EN 10025
- **Material hexagon nut:** steel resistance class 8
- **Zinc plating:** hot-dip galvanised, min. 40 - 45 µm, acc. to DIN EN ISO 146 1

TECHNICAL DATA

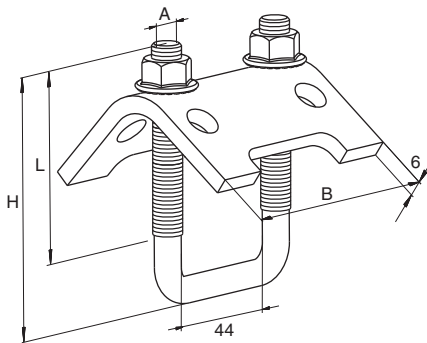

Item	Art.-No.	For profile	Thread	Width B	Height H	Sales unit
			A	B [mm]	H [mm]	[pcs]
TKR 21- 42 hdg.	538122	38/40, 21, 41	M 8	79	97	20
TKR 82 hdg.	538123	40/60, 62, 41D	M 10	79	137	20
TKR 124 hdg.	538124	62 D	M 10	79	179	10

9 Installation system FUS hot-dip galvanised

LOADS

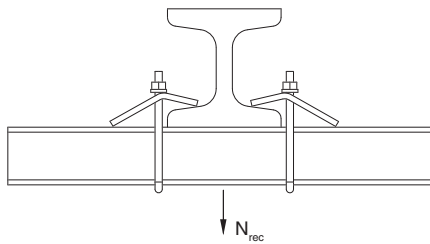

Item	Art.-No.	Max. recom. static load (centr. tension)	Tightening torque
		$N_{recom.}$ [kN]	T_{inst} [Nm]
TKR 21- 42 hdg.	538122	5.00	15
TKR 82 hdg.	538123	10.00	20
TKR 124 hdg.	538124	10.00	20

Construction elements - Brackets FFF hdg.



Frame constructions

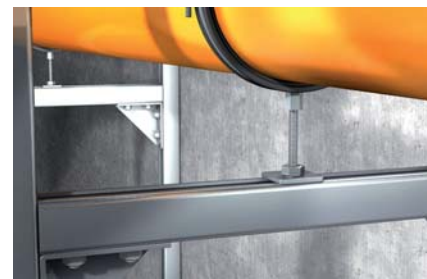

Connection on channel

APPLICATIONS

- Connecting elements for the joining or strengthening of simple channel constructions
- For indoor and outdoor applications and in environments with high stress to components due to corrosion

PROPERTIES

- **Material:** steel S235 JR (material no.10037) acc. to DIN EN 10025
- **Zinc plating:** hot-dip galvanised, min. 45 µm, acc. to DIN EN ISO 1461

TECHNICAL DATA

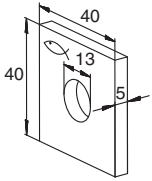

FFF 1 hdg.

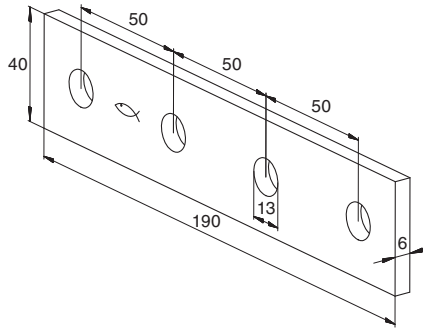

FFF 4 hdg.

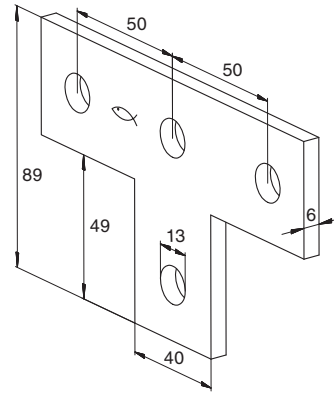

FFF 4T hdg.

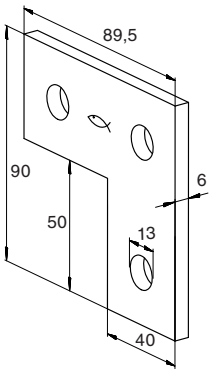

FFF 3L hdg.

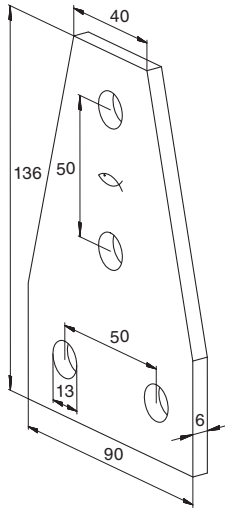

FFF 4D hdg.

Item	Art.-No.	Sales unit	
		[pcs]	
FFF 1 hdg.	537580	25	
FFF 3L hdg.	537581	25	
FFF 4 hdg.	537582	25	
FFF 4T hdg.	537583	25	
FFF 4D hdg.	537584	25	

LOADS

see Channel nut FCN Clix P hdg.

Construction elements - Mounting bracket FAF hdg.

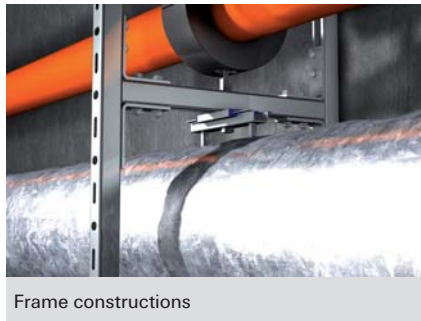

APPLICATIONS

- Connecting elements for the joining or strengthening of simple channel constructions
- For indoor and outdoor applications and in environments with high stress to components due to corrosion

PROPERTIES

- **Material:** steel S235 JR (material no.: 1.0037) acc. to DIN EN 10025
- **Zinc plating:** hot-dip galvanised, min. 45 µm, acc. to DIN EN ISO 1461

TECHNICAL DATA

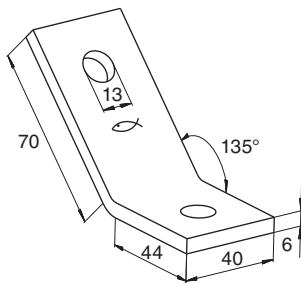

FAF 2/135° hdg.

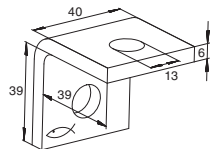

FAF 2 hdg.

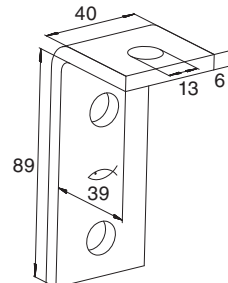

FAF 3 hdg.

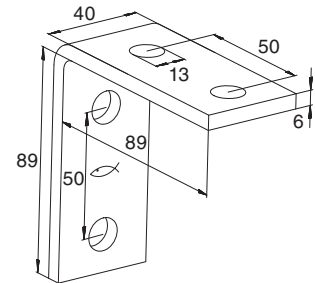

FAF 4 hdg.

Item	Art.-No.	Sales unit			
			[pcs]		
FAF 2/135° hdg.	537579		25		
FAF 2 hdg.	537576		25		
FAF 3 hdg.	537577		25		
FAF 4 hdg.	537578		25		

LOADS

see Channel nut FCN Clix P hdg.

Construction elements - Mounting brackets FUF hdg.

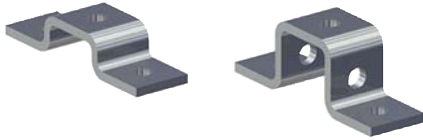

APPLICATIONS

- Connecting elements for multi-dimensional channel constructions
- For indoor and outdoor applications and in environments with high stress to components due to corrosion

ADVANTAGES/BENETITS

- The various shapes of the connecting elements offer flexibility when it comes to the installation of rail constructions.
- The holes in the connecting elements make them compatible with the FCN Clix P.
- The surface coating creates a high corrosion protection against environmental influences like humidity, water, saltwater or other corrosive substances.

PROPERTIES

- **Material:** steel S235 JR (material no. 10037) acc. to DIN EN 10025
- **Zinc plating:** hot-dip galvanised, min. 45 µm, acc. to DIN EN ISO 1461

TECHNICAL DATA

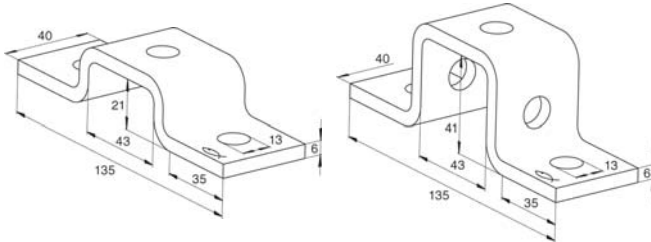

FUF 21 hdg.

FUF 41 hdg.

Item	Art.-No.	Sales unit			
			[pcs]		
FUF 21 hdg.	537588		25		
FUF 41 hdg.	537589		25		

LOADS

see Channel nut FCN Clix P hdg.

Construction elements - Mounting brackets FUF hdg.



APPLICATIONS

- Connecting elements for multi-dimensional channel constructions
- For indoor and outdoor applications and in environments with high stress to components due to corrosion

ADVANTAGES/BENETTIS

- The various shapes of the connecting elements offer flexibility when it comes to the installation of rail constructions.
- The holes in the connecting elements make them compatible with the FCN Clix P.
- The surface coating creates a high corrosion protection against environmental influences like humidity, water, saltwater or other corrosive substances.

PROPERTIES

- **Material:** steel S235 JR (material no. 10037) acc. to DIN EN 10025
- **Zinc plating:** hot-dip galvanised, min. 45 µm, acc. to DIN EN ISO 1461

TECHNICAL DATA

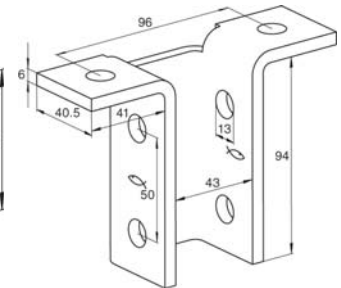
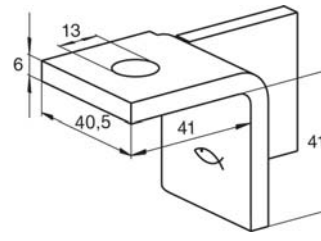
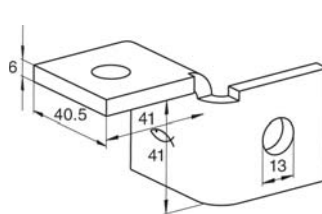
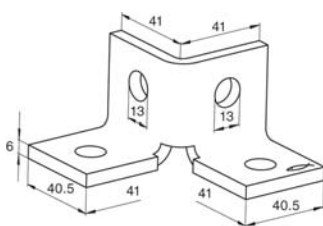

FUF 4Y hdg.

FUF 180°L hdg.

FUF 180°R hdg.

FUF 8T hdg.

Item	Art.-No.	Sales unit			
			[pcs]		
FUF 4Y hdg.	537585		20		
FUF 180°L hdg.	537586		20		
FUF 180°R hdg.	537587		20		
FUF 8T hdg.	537590		10		

LOADS

see Channel nut FCN Clix P hdg.



10

Stainless steel installation program

	page		page
Pipe clamps A2/A4		Mounting bracket FAF A4	244
Pipe clamp FRS	240	Beam clamp TKR	245
MS-L A2		Channel washer HK 41	245
Channel MS	241	Clix channel nut FCN Clix A4	246
Cantilever arm ALK A2	241	Stud screw STS A2/A4	246
T-head bolt FHS Clix A2	241	Accessories A2/A4	
Installation angle bracket MW A2	242	Threaded rod G A2/A4	247
Saddle flange SF A2	242	Threaded stud GS A4	247
Channel nut HG A2	242	Hexagonal connector VM A4	247
FUS A2/A4		Washer U A4	248
FUS Channel A2/A4	243	Hexagonal nut MU A4	248
Cantilever arm FCA A4	243	Hexagonal screw SKS A4	248
Saddle flange SF L A4	244		

Pipe clamp FRS A2/A4

TECHNICAL DATA

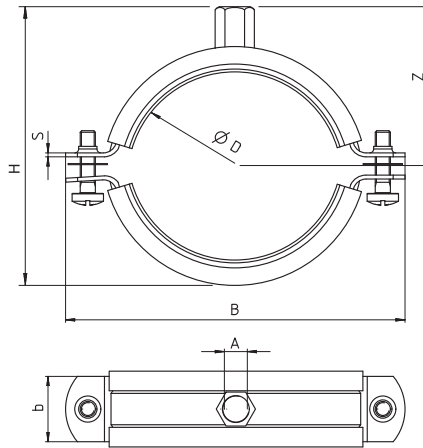

PROPERTIES

- **Material:** stainless steel A2: material-no 1.4301, acc. DIN EN 10088-1
- **Material:** stainless steel A4: material-no 1.4401, acc. DIN EN 10088-1
- **Material sound insulation insert:** EPDM; chlorine-free; silicone-free
- **Temperature range:** -40 °C to +100 °C
- **Hardness:** 55 ± 5° Shore A
- **Fire behaviour:** DIN 4102: Class B2

Item	Art.-No.	Thread	Size	Clamping range	Width B	Height H	Width x thickness clamp band	Height Z	Locking screw	Max. recom. static load (centr. tension) N _{recom.} [kN]	Sales unit
		A	[inch]	D [mm]	B [mm]	H [mm]	b x s [mm]	Z [mm]		[pcs]	
Stainless steel A2											
FRS 3/8" A2	064290	M 8	3/8"	15 - 19	62	40	20 x 1,2	23	M 6	1.00	100
FRS 1/2" A2	064536	M 8	1/2"	20 - 24	68	45	20 x 1,2	26	M 6	1.00	100
FRS 3/4" A2	064639	M 8	3/4"	25 - 30	75	52	20 x 1,2	29	M 6	1.00	100
FRS 1" A2	064646	M 8	1"	31 - 38	80	60	20 x 1,2	32	M 6	1.00	100
FRS 1 1/4" A2	064669	M 8	1 1/4"	40 - 46	90	67	20 x 1,2	37	M 6	1.00	50
FRS 1 1/2" A2	064673	M 8	1 1/2"	48 - 54	97	75	20 x 1,2	41	M 6	1.00	50
FRS 54 - 58 A2	064674	M 8	—	54 - 59	104	80	20 x 1,2	44	M 6	1.00	50
FRS 2" A2	064675	M 8	2"	60 - 64	110	85	20 x 1,2	46	M 6	1.00	50
FRS 67 - 71 A2	064688	M 8	—	67 - 71	119	92	20 x 1,2	49	M 6	1.00	25
FRS 2 1/2" A2	064689	M 10	2 1/2"	72 - 78	130	99	25 x 1,5	53	M 6	1.30	25
FRS 81 - 86 A2	064693	M 10	—	81 - 86	132	107	25 x 1,5	58	M 6	1.30	25
FRS 3" A2	064694	M 10	3"	87 - 92	144	113	25 x 1,5	60	M 6	1.30	25
FRS 95 - 103 A2	064695	M 10	—	95 - 103	156	124	25 x 1,5	66	M 6	1.30	25
FRS 4" A2	064697	M 10	4"	102 - 116	172	138	25 x 2,0	73	M 6	2.0	20
FRS 121 - 127 A2	064709	M 10	—	121 - 127	192	149	25 x 2,0	79	M 8	2.0	10
FRS 133 - 141 A2	064713	M 10	5"	133 - 141	198	163	25 x 2,0	86	M 8	2.0	10
FRS 159 - 168 A2	064714	M 10	6"	159 - 169	218	191	25 x 2,0	100	M 8	2.0	8
Stainless steel A4											
FRS 3/8" A4	064864	M 8	3/8"	15 - 19	62	40	20 x 1,2	23	M 6	1.00	100
FRS 1/2" A4	064865	M 8	1/2"	20 - 24	68	45	20 x 1,2	26	M 6	1.00	100
FRS 3/4" A4	064866	M 8	3/4"	25 - 30	75	52	20 x 1,2	29	M 6	1.00	100
FRS 1" A4	064868	M 8	1"	31 - 38	80	60	20 x 1,2	32	M 6	1.00	100
FRS 1 1/4" A4	064869	M 8	1 1/4"	40 - 46	90	67	20 x 1,2	37	M 6	1.00	50
FRS 1 1/2" A4	064870	M 8	1 1/2"	48 - 54	97	75	20 x 1,2	41	M 6	1.00	50
FRS 54 - 58 A4	064873 1)	M 8	—	54 - 59	104	80	20 x 1,2	44	M 6	1.00	50
FRS 2" A4	064874	M 8	2"	60 - 64	110	85	20 x 1,2	46	M 6	1.00	50
FRS 67 - 71 A4	064875 1)	M 8	—	67 - 71	119	92	25 x 1,2	49	M 6	1.00	25
FRS 2 1/2" A4	064879	M 10	2 1/2"	72 - 78	130	99	25 x 1,5	53	M 6	1.30	25
FRS 81 - 86 A4	064892 1)	M 10	—	81 - 86	132	107	25 x 1,5	58	M 6	1.30	25
FRS 3" A4	064893 1)	M 10	3"	87 - 92	144	113	25 x 1,5	60	M 6	1.30	25
FRS 95 - 103 A4	064894 1)	M 10	—	95 - 103	156	124	25 x 1,5	66	M 6	1.30	25
FRS 4" A4	064898	M 10	4"	102 - 116	172	138	25 x 2,0	73	M 6	2.0	20
FRS 121 - 127 A4	064899 1)	M 10	—	121 - 127	192	149	25 x 2,0	79	M 8	2.0	10
FRS 133 - 141 A4	064901 1)	M 10	5"	133 - 141	198	163	25 x 2,0	86	M 8	2.0	10
FRS 159 - 168 A4	064903	M 10	6"	159 - 168	218	191	25 x 2,0	100	M 8	2.0	8

1) Delivery time on request.

MS-L Channel A2

TECHNICAL DATA

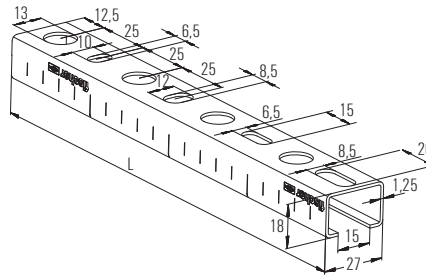

PROPERTIES

- Material: stainless steel A2: material-no 1.4301, acc. DIN EN 10088-1

Item	Art.-No.	Length	Sales unit
		L [mm]	[pcs]
MS 27/18 A2 - 2m	064905	2000	1

Weights and loads see chapter MS-L and MS

Cantilever arm ALK A2

TECHNICAL DATA

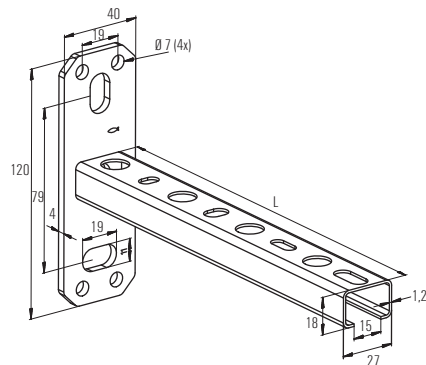

PROPERTIES

- Material: stainless steel A2: material-no 1.4301, acc. DIN EN 10088-1

Item	Art.-No.	Length	Height H	Sales unit
		L [mm]	H [mm]	[pcs]
ALK 27/18 - 200 A2	065101	200	18	20

T-head bolt FHS Clix A2

TECHNICAL DATA

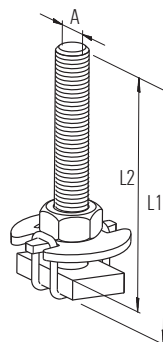

PROPERTIES

- Material: stainless steel A2: material-no 1.4301, acc. DIN EN 10088-1

Item	Art.-No.	Thread	Length	Length	Max. recommended tension load for MS-L 27/18	Max. recommended shear load	Tightening torque	Sales unit
		A	L1 [mm]	L2 [mm]	N_{rec} [kN]	V_{rec} [kN]	T_{inst} [Nm]	[pcs]
FHS CLIX 8 x 30 A2	077634	M 8	30	25	1.7	0.2	5	100
FHS CLIX 10 x 30 A2	064975	M 10	30	25	2.0	0.3	8	100

Channel nut HG A2

TECHNICAL DATA

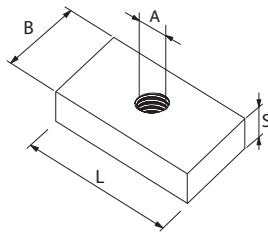

PROPERTIES

- Material: stainless steel A2: material-no 1.4301, acc. DIN EN 10088-1

Item	Art.-No.	Thread A	Thickness S [mm]	Max. recommended tension load for MS-L 27/18 N _{rec} [kN]	Max. recommended shear load V _{rec} [kN]	Tightening torque T _{inst} [Nm]	Sales unit [pcs]
HG 27 M 8 A2	077636	M 8	5	1.7	0.4	8	100
HG 27 M 10 A2	064977	M 10	5	2.0	0.5	10	100

Installation angle bracket MW A2

TECHNICAL DATA

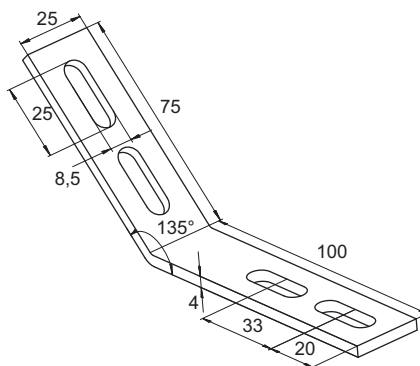

PROPERTIES

- Material: stainless steel A2: material-no 1.4301, acc. DIN EN 10088-1

Item	Art.-No.	Length l [mm]	Sales unit [pcs]
MW 27-45° A2	077626	100	25
MW 27-90° A2	077625	80	25

Saddle flange SF A2

TECHNICAL DATA

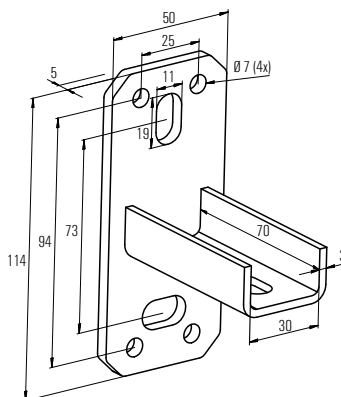

PROPERTIES

- Material: stainless steel A2: material-no 1.4301, acc. DIN EN 10088-1

Item	Art.-No.	Sales unit [pcs]
SF L 27 A2	077615	15

FUS Channel A2/A4

TECHNICAL DATA

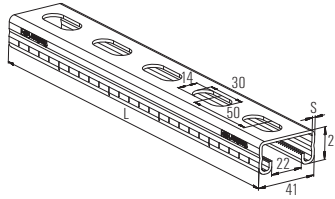

PROPERTIES

- **Material:** stainless steel A2: material-no 1.4301, acc. DIN EN 10088-1
- **Material:** stainless steel A4: material-no 1.4401, acc. DIN EN 10088-1

Item	Art.-No.	Fire test report	Length		Profile thickness		Sales unit	
				[mm]		[mm]		[pcs]
FUS 21/2,0 A2 - 2 m	504466	—		2000		2		1
FUS 41/2,0 A2 - 2 m	504468	—		2000		2		1
FUS 41/2,5 A2 - 2 m	504470	X		2000		2,5		1
FUS 21/2,0 A4 - 2 m	504472	—		2000		2		1
FUS 41/2,0 A4 - 2 m	504474	—		2000		2		1
FUS 41/2,5 A4 - 2 m	504475	X		2000		2,5		1

For loads and weight of channels and cantilever arms see page 119

10

Cantilever arm FCA A4

TECHNICAL DATA

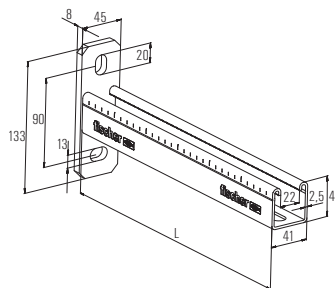
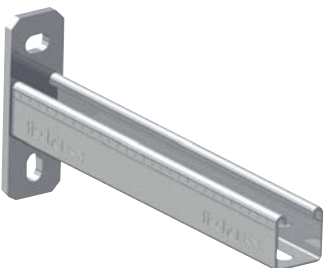

PROPERTIES

- **Material:** stainless steel A4: material-no 1.4401, acc. DIN EN 10088-1

Item	Art.-No.	Fire test report	Length		Sales unit	
				[mm]		[pcs]
FCA 41 A4 - 300	505487	X		300		1
FCA 41 A4 - 450	505488	X		450		1
FCA 41 A4 - 600	505489	X		600		1

Stainless steel properties see page 30 basic knowledge SaMontec

Stainless steel installation program

Saddle flange SF L A4

TECHNICAL DATA

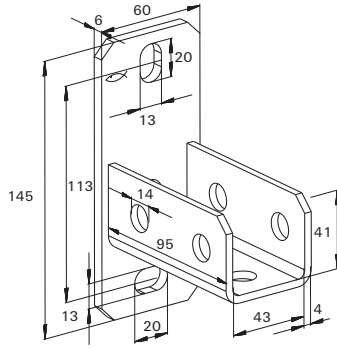
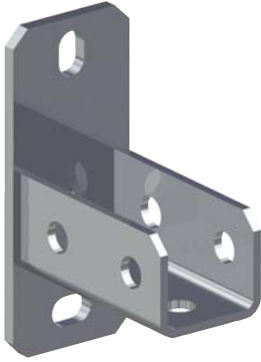

Item	Art.-No.	Fire test report	For profile	Sales unit
SF L 41 A4	504522	X	FUS 21 + FUS 41	[pcs] 10

10

Bracket FAF A4

TECHNICAL DATA

PROPERTIES

- Material: stainless steel A4: material-no 1.4401, acc. DIN EN 10088-1

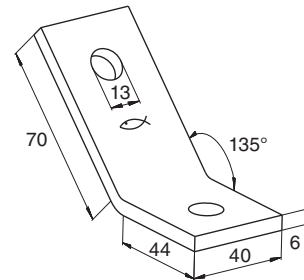
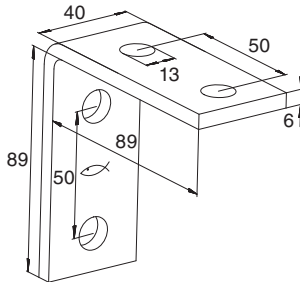
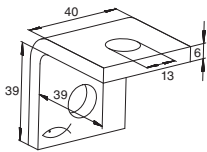

FAF 2

FAF 4

FAF 2/135°

Item	Art.-No.	Sales unit
FAF 2 A4	504519	[pcs] 25
FAF 4 A4	504520	[pcs] 25
FAF 2/135° A4	504521	[pcs] 25

Stainless steel installation program

Beam clamp TKR A4

TECHNICAL DATA

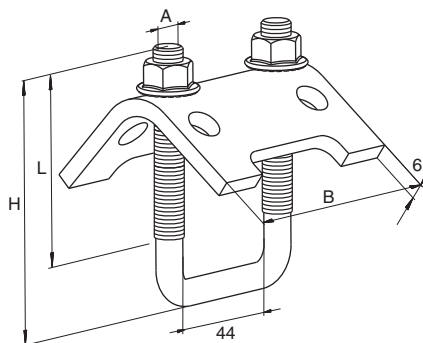

PROPERTIES

- Material: stainless steel A4: material-no 1.4401, acc. DIN EN 10088-1

Item	Art.-No.	For profile	Sales unit
TKR 21 - 42 A4	504476	FUS 21 + FUS 41	[pcs] 20

Channel washer HK 41 A4

TECHNICAL DATA

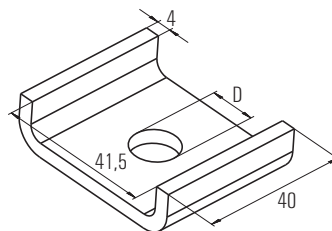

PROPERTIES

- Material: stainless steel A4: material-no 1.4401, acc. DIN EN 10088-1

Item	Art.-No.	Fire test report	For profile	Hole diameter	Sales unit
HK 41 12,5 - A4	504489	X	all FUS channels	D [mm] 12.5	[pcs] 50

Clix channel nut FCN Clix A4

TECHNICAL DATA

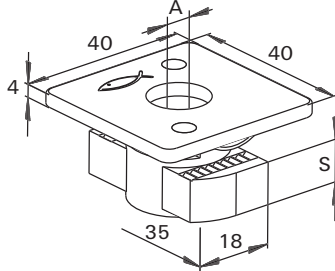
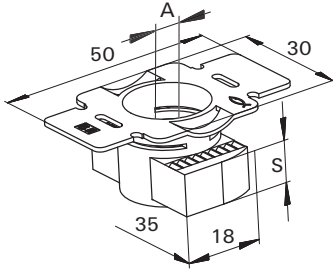

FCN Clix P

FCN Clix M

PROPERTIES

- **Material:** stainless steel A4: material-no 1.4401, acc. DIN EN 10088-1
- **Plastic:** Nylon PA 6

10

Stainless steel installation program

Item	Art.-No.	Fire test report	Thread	Thickness	Sales unit
			A	S	[pcs]
			[mm]		
FCN Clix P 8 A4	504436	–	M 8	6	100
FCN Clix P 10 A4	504437	X	M 10	8	100
FCN Clix P 12 A4	504439	X	M 12	9.5	100
FCN Clix M 8 A4	504440	–	M 8	6	100
FCN Clix M 10 A4	504447	X	M 10	8	100

Stud screw STS A2/A4

TECHNICAL DATA

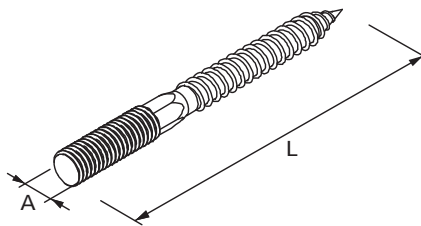
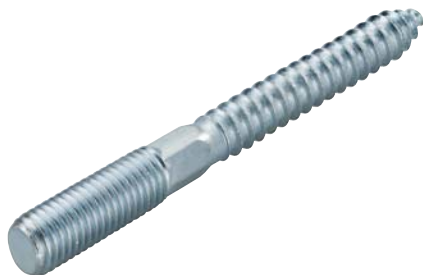

PROPERTIES

- **Material:** stainless steel A2: material-no 1.4301, acc. DIN EN 10088-1
- **Material:** stainless steel A4: material-no 1.4401, acc. DIN EN 10088-1

Item	Art.-No.	Thread	Length	Sales unit	
		A1	L	[pcs]	
			[mm]		
STS 8 x 80 A2	065132	M 8	80	100	
STS 8 x 100 A2	077643	M 8	100	100	
STS 10 x 100 A2	065153	M 10	100	100	
STS 8 x 100 A4	077715	M 8	100	100	
STS 10 x 100 A4	077716	M 10	100	100	

Threaded rod G A2/A4

TECHNICAL DATA

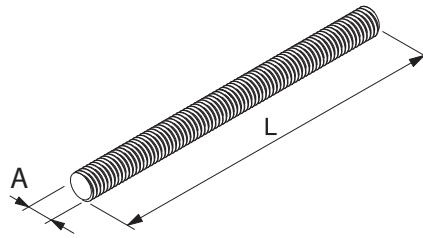

PROPERTIES

- **Material:** stainless steel A2: material-no 1.4301, acc. DIN EN 10088-1
- **Material:** stainless steel A4: material-no 1.4401, acc. DIN EN 10088-1
- **Property class:** min. 70 (A2 / A4)

Item	Art.-No.	Thread	Length	Sales unit
		A	l [mm]	[pcs]
G 8 A2	077644	M 8	1000	5
G 10 A2	065173	M 10	1000	5
G 8 A4	077645	M 8	1000	5
G 10 A4	065174	M 10	1000	5

Threaded stud GS A4

TECHNICAL DATA

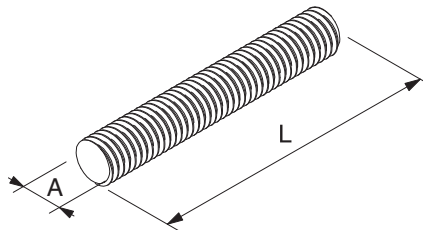

PROPERTIES

- **Material:** stainless steel A4: material-no 1.4401, acc. DIN EN 10088-1
- **Property class:** min. 70 (A2 / A4)

Item	Art.-No.	Thread	Length	Sales unit
		A	l [mm]	[pcs]
GS 8/40 A4	505536	M 8	40	100
GS 8/60 A4	505537	M 8	60	100
GS 10/40 A4	505538	M 10	40	100
GS 10/60 A4	505539	M 10	60	100

Hexagonal connector VM A4

TECHNICAL DATA

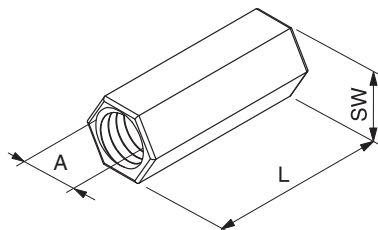

PROPERTIES

- **Material:** stainless steel A4: material-no 1.4401, acc. DIN EN 10088-1

Item	Art.-No.	Length	Thread	Width across nut	Sales unit
		l [mm]	A	○ SW [mm]	[pcs]
VM M8 A4	505540	30	M 8	11	100
VM M10 A4	505541	30	M 10	13	100

Washer U A4

TECHNICAL DATA



PROPERTIES

- **Material:** stainless steel A4: material-no 1.4401, alternative 1.4571 acc. DIN EN 10028-7

Item	Art.-No.	Thickness	External-Ø	Hole diameter	Sales unit
		S [mm]	d [mm]	D [mm]	[pcs]
U 8 x 28 A4	505542	2	28	8.4	100
U 8 x 40 A4	505543	3	40	8.4	100
U 10 x 28 A4	505544	2	30	10.5	100
U 10 x 40 A4	505545	3	40	10.5	100
U 12 x 24 A4	505546	2	24	12.5	100

Hexagonal nut MU A4

TECHNICAL DATA

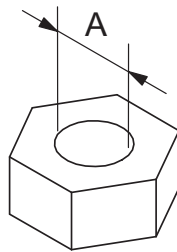

PROPERTIES

- **Material:** stainless steel A4, acc. to DIN EN ISO 3506-2
- **Property class:** min. 50, acc. to DIN EN ISO 3506-2

Item	Art.-No.	Thread	Width across nut	Sales unit
		A	○ SW [mm]	[pcs]
MU M 8 A4	077642	M 8	13	100
MU M 10 A4	077641	M 10	17	100

Hexagonal screw SKS A4

TECHNICAL DATA

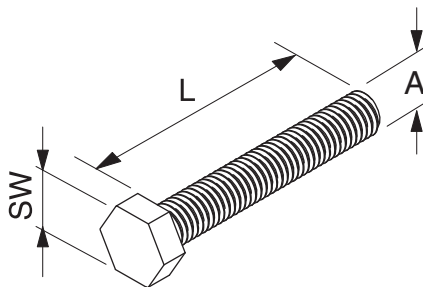

PROPERTIES



- **Material:** stainless steel A4, material-no. 1.4401, acc. to DIN EN ISO 3506-1
- **Property class:** min. 70, acc. to DIN EN ISO 3506-1)

Item	Art.-No.	Thread	Width across nut	Sales unit
		A	○ SW [mm]	[pcs]
SKS M 10 x 30 A4	505547	M 10	17	100
SKS M 12 x 30 A4	505548	M 12	19	100



11

Air conditioner fixings

	page
Kit for air conditioner fixing	
Air conditioner fixing MCE	 252
Air conditioner fixing KSU	 254
Sound absorption element PA	 255

The complete kit for air conditioner fixing on walls



APPLICATIONS

- Universal fixing for air conditioners
- MCE Klima Klik - air conditioner fixing onto walls with max. fixing distance of 760 mm on the horizontal channel
- Please consider: load bearing capacity of the wall and the quality of the substrate

ADVANTAGES/BENEFITS

- The complete kit including anti vibration dumper, SX plug and screws offers an optimised installation security.
- The brackets with quick snap (Klik) simplify and shorten the installation.
- The horizontal channel of the MCE Klima Klik allows a flexible adjustment of the brackets and simplifies the installation additionally.
- The MCE Klima Klik horizontal channel with snap-on bubble level enables the adjustment without additional tools.

PROPERTIES

- **Material:** steel
- **Coating:** powder coating
- **Colour:** RAL 9002

11

Air conditioner fixings

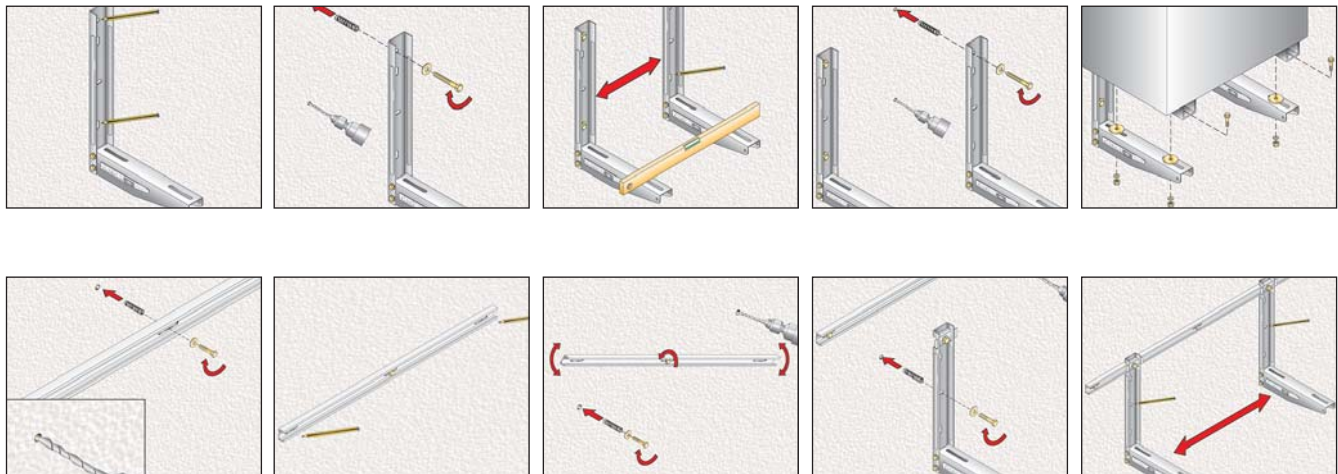

TECHNICAL DATA

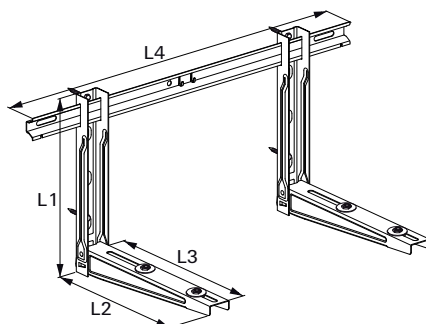
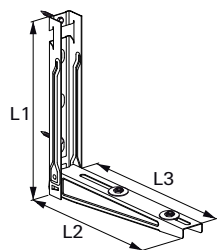

KLIMA EASY KLIK

KLIMA KLIK

Item	Art.-No.	Length	Length	Length	Length
		L1 [mm]	L2 [mm]	L3 [mm]	L4 [mm]
KLIMA EASY KLIK	521760 ¹⁾	400	420	380	—
KLIMA KLIK 420	521761 ¹⁾	400	420	380	780

LOADS

Item	Art.-No.	Max. recommended static load load case 1	Max. recommended static load load case 2
		F_{rec} [kN]	F_{rec} [kN]
KLIMA EASY KLIK	521760 ¹⁾	1.0	1.0
KLIMA KLIK 420	521761 ¹⁾	1.0	1.0

¹⁾ The loads are valid for the use in pairs (two consoles).

Load case 1

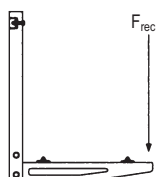

Load case 2

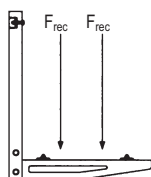

The complete kit for fixing of Air conditioners, pumps or ventilators on walls

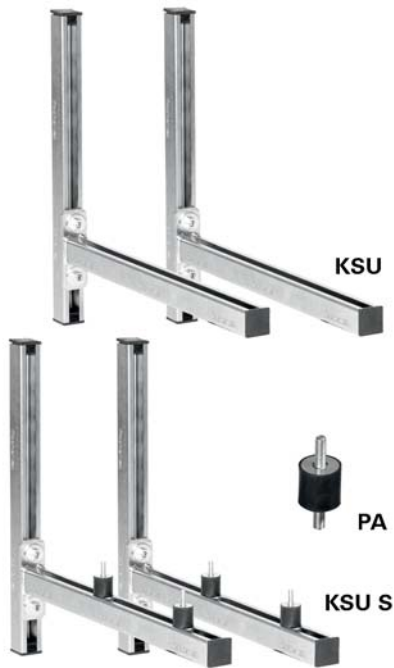

11

Air conditioner fixings

APPLICATIONS

- Secure attachment of air conditioners (pumps and fans) to walls with or without sound insulation element

ADVANTAGES/BENEFITS

- The KSU-S complete kit includes 4 noise protection pieces, and offers an optimised noise reduction.
- The horizontal channel with different lengths and the SM sliding nut of the KSU set allow a flexible adjustment of the noise protection pieces to simplify the installation.
- The included T-head bolt for the fixing of the cantilevers offers the possibility of an easy adjustment and a time saving installation.
- The KSU set consists of finished cut MS 38/40 channels for instant use and avoids the accumulation of single pieces.

PROPERTIES

- Material:** steel DX51D+Z 275 MA-C (material no. 1.0226+Z) acc. to DIN EN 10327
- Zinc plating:** sendzimir-galvanised, app. 15 µm

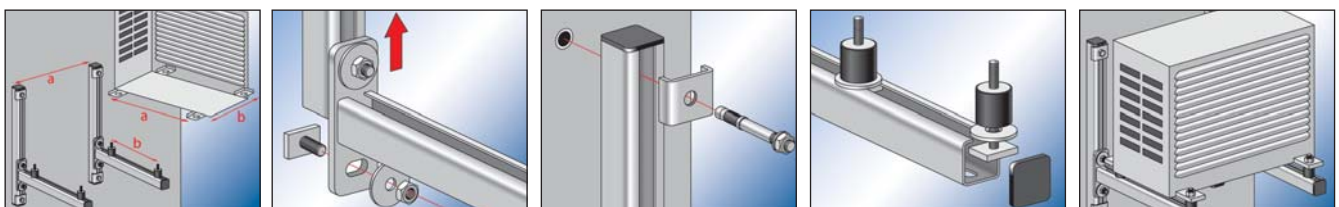

TECHNICAL DATA

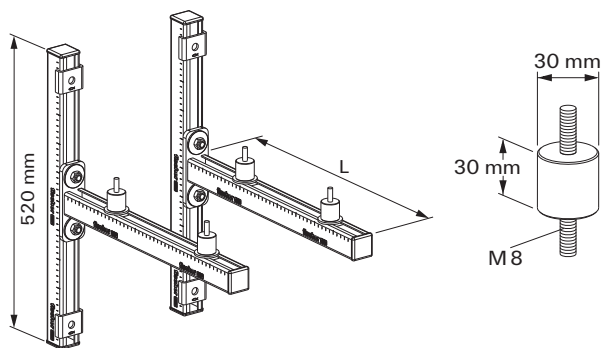

KSU

PA 30 x 30

Item	Art.-No.	Length l [mm]	Construction with noise protection	Sales unit [pcs]
KSU 440	512712 1)	440	—	1
KSU 520	512713 1)	520	—	1
KSU 600	512714 1)	600	—	1
KSU S 440	512709 1)	440	yes	1
KSU S 520	512710 1)	520	yes	1
KSU S 600	512711 1)	600	yes	1
PA 30 x 30	512715	—	—	4

LOADS

Item	Art.-No.	Max. recommended static load load case 1	Max. recommended static load load case 2
		F_{rec} [kN]	F_{rec} [kN]
KSU 440	512712 1)	1.5	1.5
KSU 520	512713 1)	1.5	1.5
KSU 600	512714 1)	1.5	1.5
KSU S 440	512709 1)	1.5	1.5
KSU S 520	512710 1)	1.5	1.5
KSU S 600	512711 1)	1.5	1.5

1) The loads are valid for the use in pairs (two consoles).

Load case 1

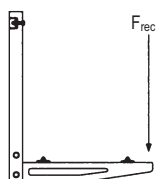

Load case 2

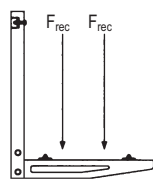



12

Electrical fixings

		page		page
ClipFix plus LS/ES/ZS		258	Nail disc NSB	 274
ClipFix plus SD		260	Spacer pipe clamp AM	 276
Cable clasp KB		262	Conduit clip BSM	 278
Cable harness SHA		264	Impact nail ED	 280
Pipe clip RC		266	Cable tie BN / UBN	 282
Pipe clip FC		268	Wireclip WIC	 284
Saddle clip SCH		270		
Nail clip NS / MNS		272		

The user-friendly clip fixing for pipes and conduits



BUILDING MATERIALS

- Concrete
- Solid pumice block
- Solid sand-lime brick
- Natural stone with dense structure
- Solid brick

CHARACTERISTICS



ADVANTAGES

- The complete element combines anchor, screw and clamp. This saves materials, allows for one-handed installation, and reduces assembly time.
- The slimline geometry of the fixing element only protrudes slightly, thus saving space.
- The three different sizes of each of the cable strap LS, twin clamp ZS and single clamp ES cover a range of cable diameters, thus reducing storage.
- The long-lasting nylon material is flame resistant, halogen- and silicone-free, can be used all year round, including during a frost. This ensures a high level of safety.

APPLICATIONS

- For fixing of:**
- Individual electric cables
 - Cable bundles
 - Flexible pipes
 - Rigid plastic pipes

FUNCTIONING

- The clip fixing is set into the drill hole without the need for any additional screws and fixes the pipe directly to the base material.
- The clamping force of the locking catch allows the ClipFix to hold itself in the drill hole.
- Place the clasp of the cable strap LS into the drill hole so that it is level and the teeth grip.
- Recommended loads (safety factor 4): cable strap LS up to 6 kg, twin clamp ZS and single clamp ES up to 11 kg.
- Temperature resistance once installed from -20 °C to +80 °C.

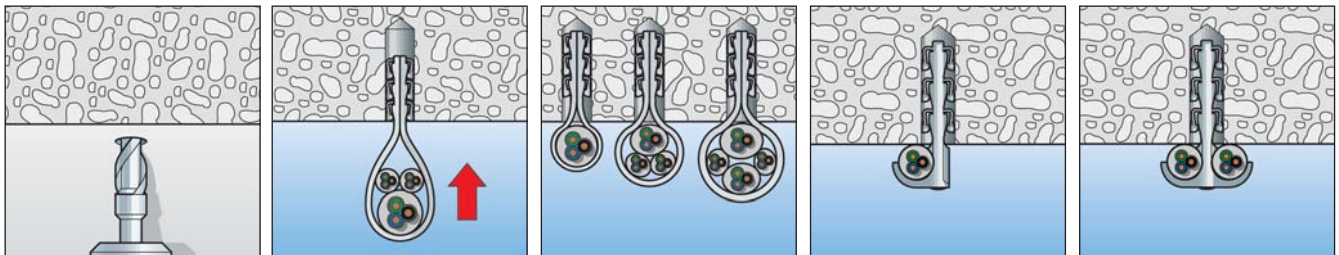

TECHNICAL DATA



Clip fix plus cable strap **SF plus LS**



Clip fix plus single clamp **SF plus ES**



ClipFix plus twin clamp **SF plus ZS**

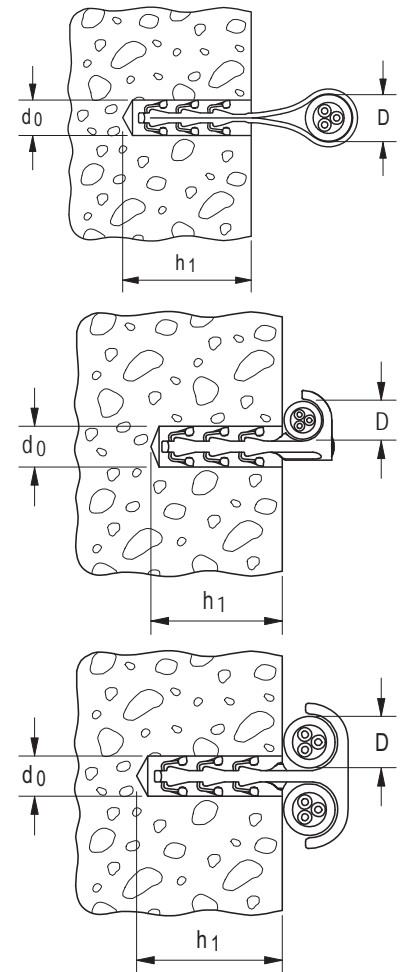

Item	Art.-No.	Drill hole d_0 [Ø mm]	Min. drill hole depth h_1 [mm]	Clamping range D [mm]	Sales unit [pcs]			
SF plus LS 3/13	058155	6	35	3 - 13	100			
SF plus LS 8/28	058156	6	50	8 - 28	100			
SF plus LS 20/40	058157	6	50	20 - 40	100			
SF plus ES 10	048151	6	40	3 - 12	100			
SF plus ES 18	048152	6	40	10 - 25	100			
SF plus ES 28	058183	6	40	15 - 31	100			
SF plus ZS 10	058184	6	35	3 - 12	100			
SF plus ZS 18	048161	6	40	10 - 25	100			
SF plus ZS 28	048162	6	40	15 - 31	75			

The user-friendly clip fixing for cable ducts and cable clasps



Fixing cable ducts

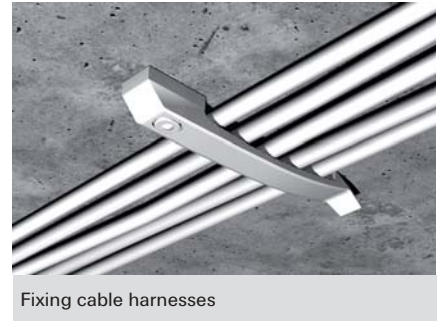

Fixing cable harnesses

BUILDING MATERIALS

- Concrete
- Solid pumice block
- Solid sand-lime brick
- Natural stone with dense structure
- Solid brick

CHARACTERISTICS



ADVANTAGES

- The ClipFix plus SD combines anchor and screw. This saves on materials and makes it easier to affix cable ducts that are difficult to access without the need for additional tools.
- The simple clip fixing reduces installation time.
- The extended shank of the FS plus SD 40 allows bridging of non-bearing plaster layers, as well as the fixing of thicker attachments.
- The long-lasting nylon material is flame resistant, halogen- and silicone-free. It can be used all year round, including during a frost. This ensures a high level of safety.

APPLICATIONS

- For fixing of:**
- Cable channels
 - Cable clasps
 - Installation base cable harness
 - Flat building components

FUNCTIONING

- To fix, manually place the ClipFix plus SD directly into the drill hole. No additional screws are needed.
- The clamping force of the locking catch allows the ClipFix to hold itself in the drill hole.
- Recommended loads (safety factor 4): clip fixing SD up to 11 kg.
- Temperature resistance once installed from -20 °C to +80 °C.

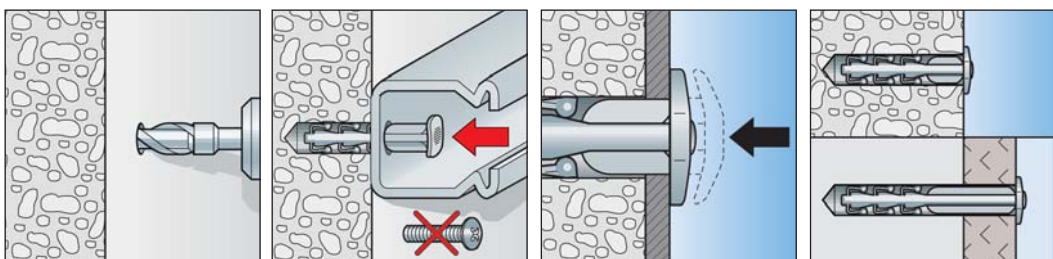

TECHNICAL DATA



fischer ClipFix plus clip fixing **SF plus SD**

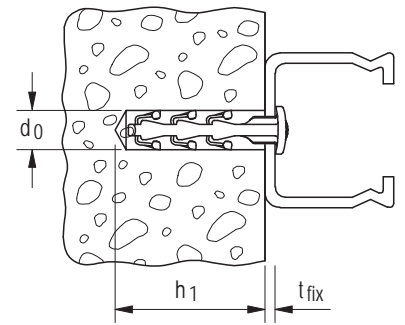

Item	Art.-No.	Drill hole d_0 [Ø mm]	Min. drill hole depth h_1 [mm]	Max. usable length t_{fix} [mm]	Sales unit [pcs]			
SF plus SD 30	058178	6	35	4	200			
SF plus SD 40	058179	6	35	15	100			

The flat cable clasp for space-saving cable fixing

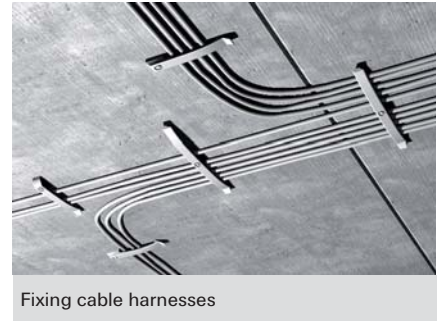
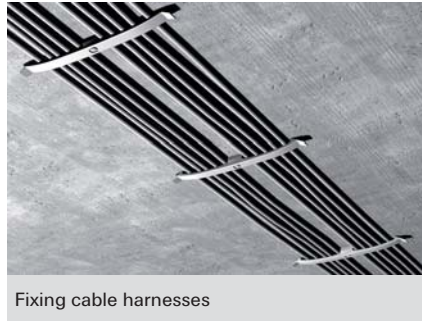

BUILDING MATERIALS

When using ClipFix SD:

- Concrete
- Solid pumice block
- Solid sand-lime brick
- Natural stone with dense structure
- Solid brick

CHARACTERISTICS



ADVANTAGES

- The flat design of the KB cable clasp allows for a space-saving cable fixing, and simplifies subsequent cable-laying.
- The combination of cable clasp KB and ClipFix SD allows for one-handed installation, thus enabling a flexible and economic installation.
- The long-lasting nylon material is halogen- and silicone-free. It can be used all year round, including during a frost. This ensures a high level of safety.

APPLICATIONS

- For the fixing of several individual cables

FUNCTIONING

- The cables are clamped under the clasps. Additional cables can be easily laid even after installation.
- The cable clasp KB is adapted to be fixed either with fixing SD or with Hammerfix N6.
- Manually place the ClipFix plus SD directly into the drill hole. No additional screws are needed.
- The Hammerfix N is expanded when the nail is driven in, and holds by friction in the drill hole.
- Temperature resistance once installed from -20 °C to +80 °C.

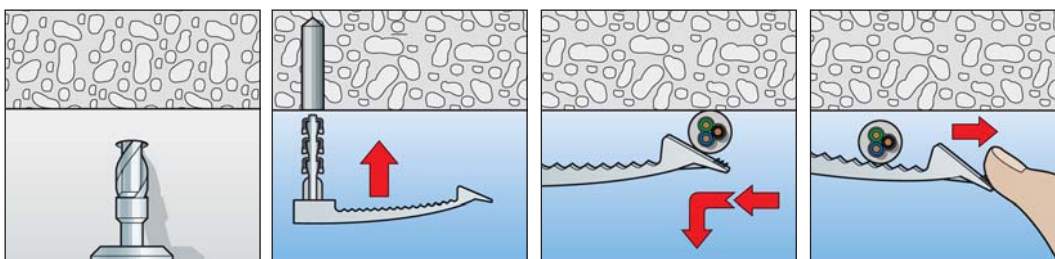

TECHNICAL DATA



ClipFix plus cable clasp **SF plus KB 8**



ClipFix plus cable clasp **SF plus KB 16**



Cable clasp **KB 8**



Cable clasp **KB 16**

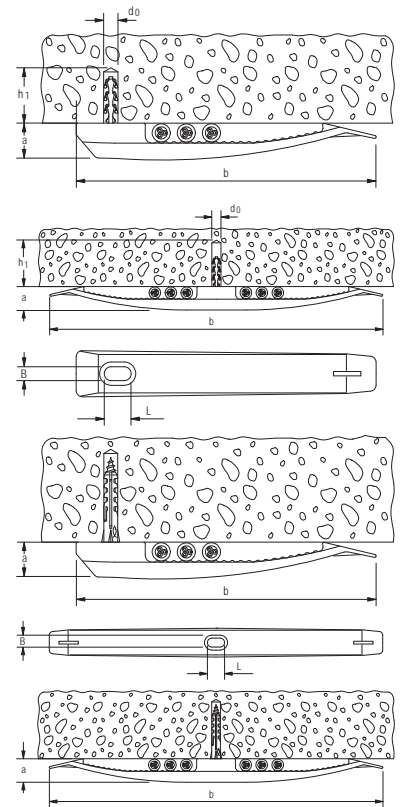

Item	Art.-No.	Drill hole	Min. drill hole depth	Dimensions	Dimension of slot	Max. number of ducts	Sales unit
		d_0 [Ø mm]	h_1 [mm]	$a \times b$ [mm]	$B \times L$ [mm]		
SF plus KB 8	048171	6	35	15 x 133	6 x 10	8 ducts NYM 3 x 1,5	50
SF plus KB 16	048172	6	35	15 x 230	6 x 10	16 ducts NYM 3 x 1,5	25
KB 8	058135	—	—	15 x 133	6 x 10	8 ducts NYM 3 x 1,5	50
KB 16	058136	—	—	15 x 230	6 x 10	16 ducts NYM 3 x 1,5	50

The adaptable cable harness for fixing cable bundles

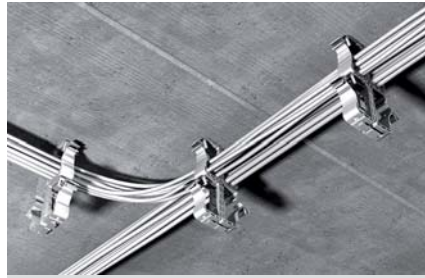

Fixing cable bundles

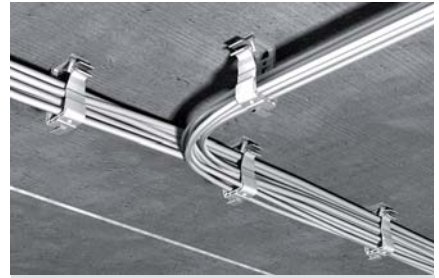

Fixing cable bundles

BUILDING MATERIALS

When using ClipFix SD:

- Concrete
- Solid pumice block
- Solid sand-lime brick
- Natural stone with dense structure

CHARACTERISTICS



ADVANTAGES

- The seal of the cable harness SHA makes it easy to lay cables at a later date, thus ensuring high user-friendliness.
- Combining several SHA cable harnesses allows for a cost-effective fixing of cables to just one MS installation base.
- The MS installation base allows for various fixing options, and allows for great flexibility for the installation.
- The long-lasting nylon material is halogen- and silicone-free. It can be used all year round, including during a frost. This ensures a high level of safety.

APPLICATIONS

For fixing of:

- Electric cables, loose and bundled

FUNCTIONING

- Cable bundles can be laid in the cable harness SHA. The seal makes it easy to lay cables at a later date.
- The cable harness SHA can either be affixed with ClipFix plus, installation base MS or with plugs and screws.
- Several SHA cable harnesses can be combined below one another.
- The SHA cable harnesses can also be lined up adjacent to one another with the connection piece SHA KP.
- The maximum installation distance of 80 cm must not be exceeded.
- Temperature resistance once installed from -20 °C to +80 °C.

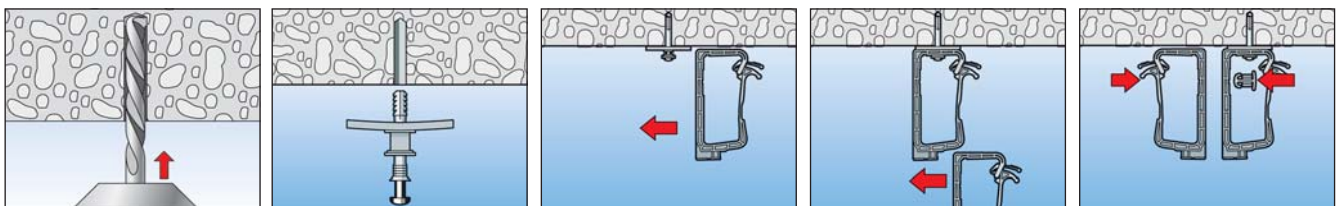

TECHNICAL DATA



Cable harness **SHA**

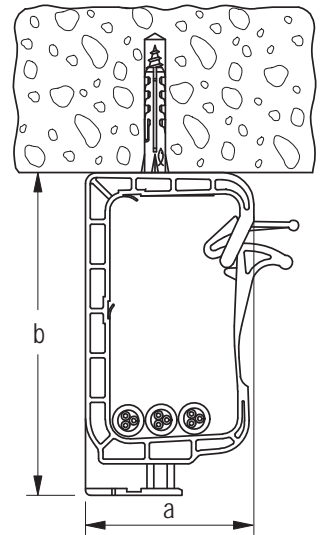

Installation base **SHA MS**

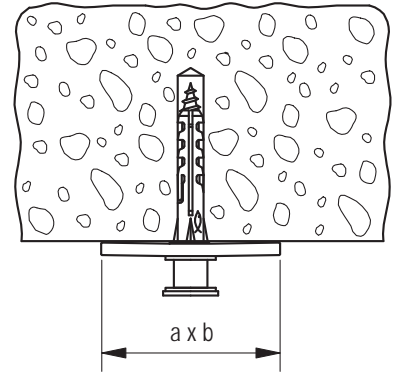

Steckfix plus installation base **SF plus MS**

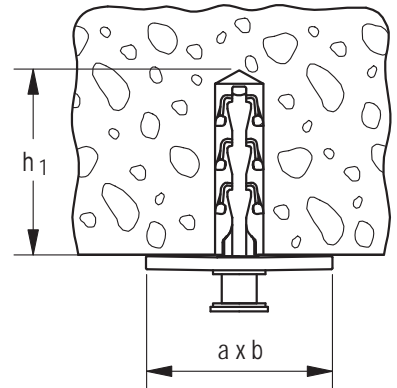

Connection piece **SHA KP**

Item	Art.-No.	Drill hole	Min. drill hole depth	Dimensions	Max. number of ducts	Sales unit	
		d_0 [Ø mm]	h_1 [mm]	$a \times b$ [mm]		[pcs]	
SHA 15	058139	–	–	93 x 49	15 ducts NYM 3 x 1,5	50	
SHA 30	058140	–	–	128 x 59	30 ducts NYM 3 x 1,5	25	
SHA MS	058141	–	–	41 x 27	connection piece	50	
SF plus MS	048181	6	35	41 x 27	installation base with clip-plug	50	
SHA KP	058142	–	–	–	installation base	50	

The convenient pipe fixing

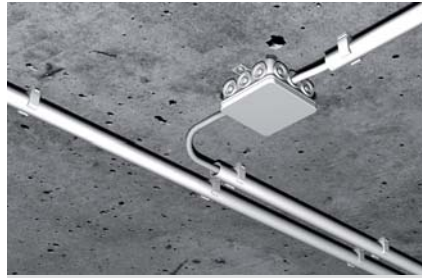

Fixing plastic insulating conduits



Fixing plastic insulating conduits

BUILDING MATERIALS

When using ClipFix SD:

- Concrete
- Solid pumice block
- Solid sand-lime brick
- Natural stone with dense structure
- Solid brick

CHARACTERISTICS



ADVANTAGES

- The pipe clip RC can be used with pre-installed clip fixing SD, with Hammerfix N 6 or in 11 mm C-shaped profile-rails, and thus allows for a flexible and cost-effective installation.
- The 6 mm-long hole allows for the optimal alignment of the pipe fixing and ensures a more user-friendly installation.
- Two additional pipe clips can be added to the sides of a pre-fixed pipe clip. This saves assembly time and materials.
- The long-lasting nylon material is halogen- and silicone-free. It can be used all year round, including during a frost. This ensures a high level of safety.

APPLICATIONS

For fixing of:

- Plastic insulation pipes

FUNCTIONING

- Plastic insulation pipes are laid into the pipe clip. The pre-tensioning of the pipe clip holds the pipes securely.
- The pipe clip RC is adapted to be fixed with either clip fixing SD or Hammerfix N 6.
- Manually place the ClipFix plus SD directly into the drill hole. No additional screws are needed.
- The Hammerfix N is expanded when the nail is driven in, and holds by friction in the drill hole.
- Temperature resistance once installed from -20 °C to +80 °C.

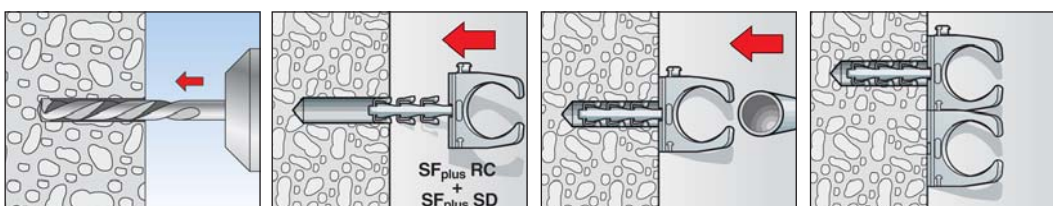

TECHNICAL DATA



Clipfix plus pipe clip **RC**



Pipe clip **RC PG**

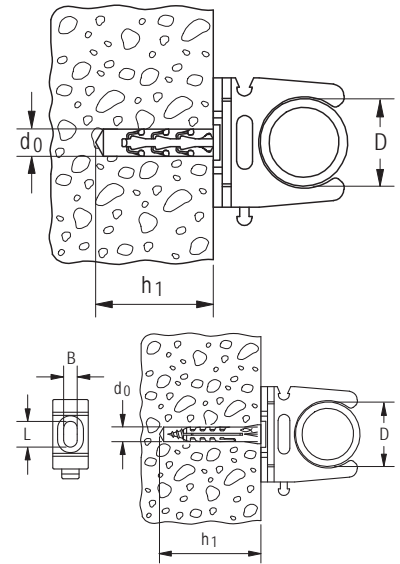

Item		Drill hole	Min. drill hole depth	Suitable for IEC	Clamping range	Dimension of slot	Sales unit
		d_0 [Ø mm]	h_1 [mm]		D [mm]	B x L [mm]	
SF plus RC IEC 12	048190	6	35	12	12 - 13	6 x 7	100
SF plus RC IEC 16	048191	6	35	16	15 - 16	6 x 8	100
SF plus RC IEC 20	048193	6	35	20	20 - 21	6 x 10	100
SF plus RC IEC 25	048197	6	35	25	24 - 25	6 x 10	50
SF plus RC IEC 32	048198	6	35	32	31 - 32	6 x 10	25
SF plus RC IEC 40	048199	6	35	40	38 - 40	6 x 10	25
RC IEC 12	058194	–	–	12	12 - 13	6 x 7	100
RC IEC 16	058120	–	–	16	15 - 16	6 x 8	100
RC IEC 20	058122	–	–	20	20 - 21	6 x 10	100
RC IEC 25	058198	–	–	25	24 - 25	6 x 10	50
RC IEC 32	058199	–	–	32	31 - 32	6 x 10	40
RC IEC 40	058200	–	–	40	39 - 40	6 x 10	40
RC IEC 50	079194	–	–	50	50 - 51	6 x 10	20
RC IEC 63	079196	–	–	63	62 - 64	6 x 10	15

The flexible pipe clip for various diameters

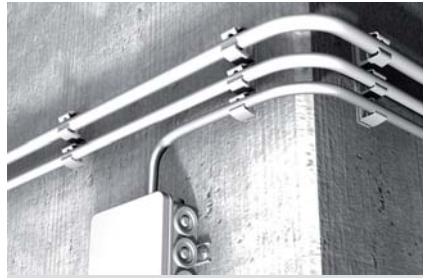

Cable fixing



Fixing plastic insulating conduits

BUILDING MATERIALS

When using Hammerfix N:

- Concrete
- Vertically perforated brick
- Hollow blocks made from lightweight concrete
- Perforated sand-lime brick
- Solid sand-lime brick
- Building brick
- Natural stone
- Aerated concrete
- Solid panel made from gypsum
- Solid brick made from lightweight concrete

CHARACTERISTICS



ADVANTAGES

- The flexible pipe clip socket ensures a secure hold for various cable and pipe diameters, and reduces the number of products required.
- The pipe clip FC can be installed with both N 5 Hammerfixes and 11 mm-C-shaped profile-rails, and thus offers great flexibility.
- Two additional pipe clips can be added to the sides of a pre-fixed clip clamp. This saves assembly time and materials.
- The long-lasting nylon material is halogen-free. It can be used all year round, including during a frost. This ensures a high level of safety.

APPLICATIONS

For fixing of:

- Electric cables
- Flexible and rigid plastic insulating pipes

FUNCTIONING

- The cable or pipe is laid in the pipe clip FC. The pre-tensioning of the pipe clip holds the cables or pipes securely.
- The pipe clip FC is adapted to be fixed with N 5 Hammerfixes.
- The Hammerfix N is expanded when the nail is driven in, and holds by friction in the drill hole.
- Temperature resistance once installed from -40 °C to +80 °C.

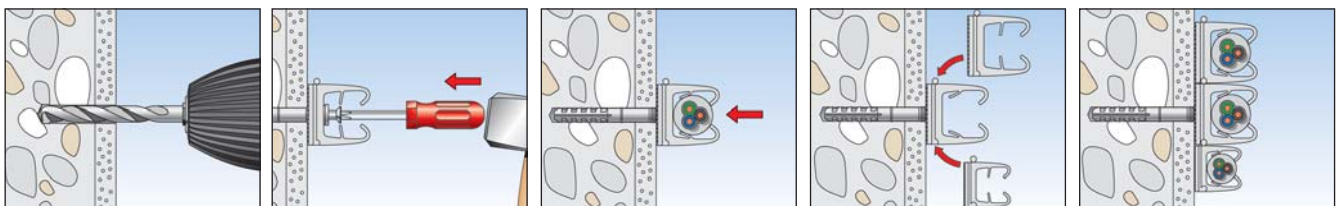

TECHNICAL DATA



Pipe clip FC

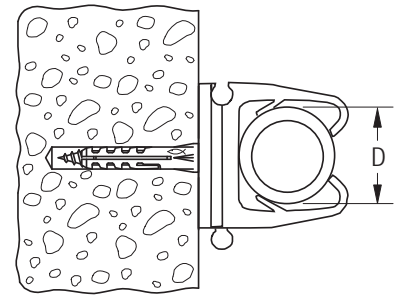

Item	Art.-No.	Clamping range D [mm]	Sales unit [pcs]					
FC 6 - 9 GR	068060	6 - 9	100					
FC 9 - 12 GR	068062	9 - 12	100					
FC 12 - 16 GR	068064	12 - 16	50					
FC 16 - 20 GR	068066	16 - 20	25					

The flexible cable clamp for various diameters

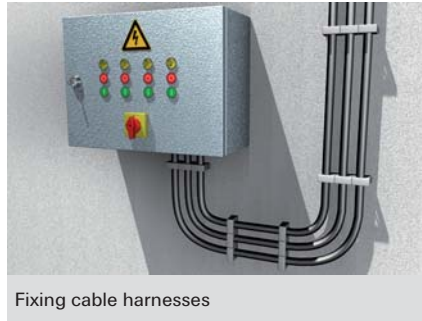

Fixing cable harnesses

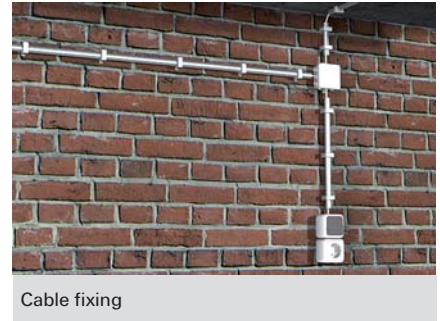

Cable fixing

BUILDING MATERIALS

When using Hammerfix N:

- Concrete
- Vertically perforated brick
- Hollow blocks made from lightweight concrete
- Perforated sand-lime brick
- Solid sand-lime brick
- Building brick
- Natural stone
- Aerated concrete
- Solid panel made from gypsum
- Solid brick made from lightweight concrete

CHARACTERISTICS



12

Electrical fixings

ADVANTAGES

- With its elastic spring tabs, the saddle clip SCH can bear different cable diameters. This increases flexibility and reduces the number of products required.
- Additional clips can be added to the sides of a pre-fixed clip. This saves installation time and materials.
- The long-lasting nylon material is halogen- and silicone-free. It can be used all year round, including during a frost. This ensures a high level of safety.

APPLICATIONS

For fixing of:

- Electric cables
- Flexible and rigid plastic insulating pipes

FUNCTIONING

- The cables or pipes are laid in the saddle clip SCH and fixed by inserting the locking latch.
- The internal tabs adapt to fit various cable or pipe diameters.
- The saddle clip SCH is adapted to be fixed with N 5 Hammerfixes.
- The Hammerfix N is expanded when the nail is driven in, and is held in place by friction in the drill hole.
- Temperature resistance once installed from -40 °C to +80 °C.

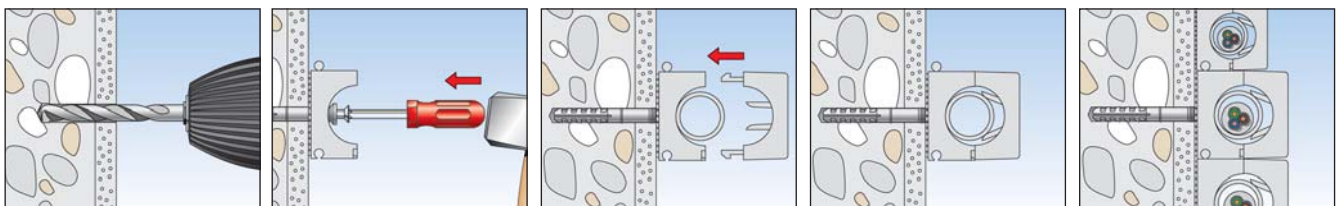



Saddle **SCH**, colour: Nylon transparent

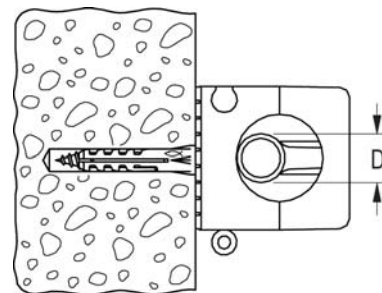

Saddle **SCH**, colour: grey RAL 7035

	Art.-No.		Clamping range D [mm]	Dimension of insulated pipes	Sales unit [pcs]			
	Grey RAL 7035	Nylon trans- parent						
SCH 812	068012	060012	8 - 12	6 x 1 - 8 x 1	100			
SCH 1216	068016	060016	12 - 16	10 x 1 - 12 x 1	50			
SCH 1619	068019	060019	16 - 19	—	50			
SCH 1623	068023	060023	16 - 23	15 x 1 - 18 x 1	50			
SCH 2332	068032	060032	23 - 32	22 x 1 - 22 x 1,5	25			
SCH 3242	—	060042	32 - 42	22 x 1 - 22 x 1,5	25			

The fast fixing for electric cables



BUILDING MATERIALS

- Hardboard
- Wood
- Aerated concrete
- Chipboard
- Plywood
- Solid gypsum panels and other plastered substrates

CHARACTERISTICS



ADVANTAGES

- The nail clip features a pre-assembled nail, allowing for a fast fixing, thus reducing assembly time.
- The small space required for fixing simplifies installation in narrow spaces.
- The nail clip MNS covers cable diameters from 4 mm to 14 mm with just 3 sizes.

APPLICATIONS

- To fix electric cables with varying diameters

FUNCTIONING

- Position the nail clip with the laid cable. Hammer in the pre-assembled nail with a hammer.

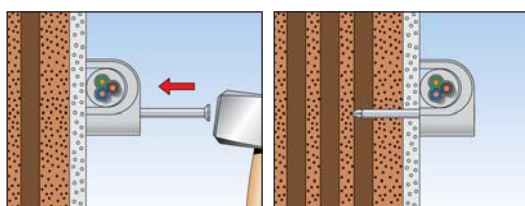

TECHNICAL DATA



Nail clip **NS**



Nail clip **MNS**

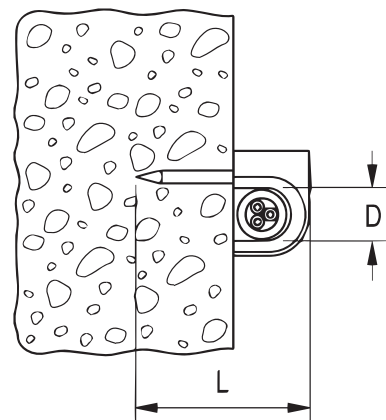

Item	Art.-No.	For cable [Ø mm]	Clamping range D [mm]	Length of nail		Sales unit [pcs]			
				L [mm]					
NS 7	058173	7	7	25		100			
NS 8	058174	8	8	25		100			
NS 9	058175	9	9	25		100			
NS 10	058176	10	10	30		100			
NS 12	058177	12	12	35		100			
MNS 4-7	094673	–	4 - 7	25		100			
MNS 7-11	094674	–	7 - 11	25		100			
MNS 10-14	094675	–	10 - 14	30		100			

The secure cable fixing in wall slots



BUILDING MATERIALS

- Hardboard
- Wood
- Chipboard
- Plywood
- Solid panel made from gypsum

ADVANTAGES

- The nail disc NSB allows for use in two slot widths, thus offering high flexibility for the installation.
- The vaulted structure of the nail disc ensures an optimal contact pressure and, as such, for a secure hold.
- The flat nail disc only protrudes slightly, and can thus be easily plastered over.
- The nail disc NSB is made from high-strength polypropylene. The nail is made from hardened, galvanised steel. The tried and tested material combination for in-wall installation.

APPLICATIONS

- For fixing cables in wall slots

FUNCTIONING

- Align the nail disc with either dimensions 27 mm or 34 mm, depending on the slot width, and hit the nail in with the hammer.
- The disc fixes the cable in the wall slot.

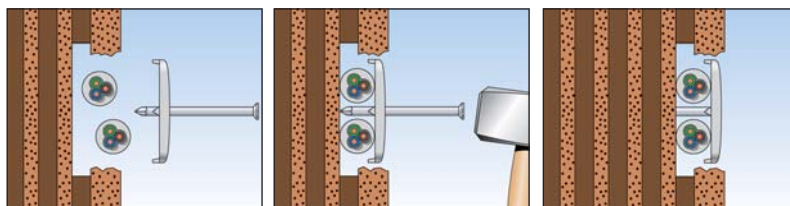

TECHNICAL DATA

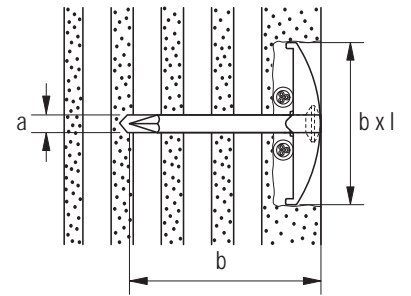
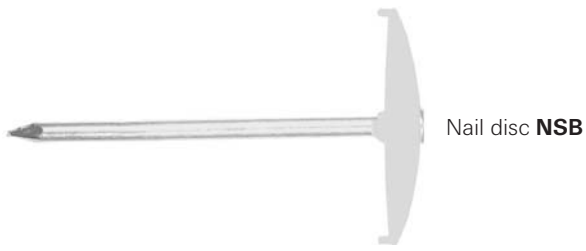

Item	Art.-No.	Dimension of nail	Dimension of disc	Sales unit				
		a x b [mm]	b x l [mm]	[pcs]				
NSB 2/40	048308	2 x 40	27 x 34	200				
NSB 2/50	048309	2 x 50	27 x 34	150				
NSB 2/60	048310	2 x 60	27 x 34	100				
NSB 3/40	048311	3 x 40	27 x 34	150				
NSB 3/50	048312	3 x 50	27 x 34	150				
NSB 3/60	048313	3 x 60	27 x 34	100				

The installation-friendly metal spacing disc for cables and pipes



Fixing steel armoured conduits



Fixing conduits

BUILDING MATERIALS

When using nail anchor FNA II:

- Concrete
- Solid sand-lime brick
- Natural stone with dense structure
- Pre-stressed concrete hollow slabs

When using Hammerfix N:

- Concrete
- Solid sand-lime brick
- Building brick
- Natural stone
- Solid brick made from lightweight concrete

ADVANTAGES

- The fast-locking latch ensures easy opening and closing without completely removing the screw, and allows for a simple and fast installation.
- The pre-fitted combination screw with conventional slotted or recessed screw head allows for the use of different screwdrivers, thus allowing for a simple installation.

APPLICATIONS

For fixing of:

- Steel conduits
- Electric cables

FUNCTIONING

- The spacer clamp AM with M6 thread can either be affixed with fischer nail anchor FNA II 6x30 M6x43, stud screw STST 6x60 and STST 6x80 or with Hammerfix N 6x40/10 M6.

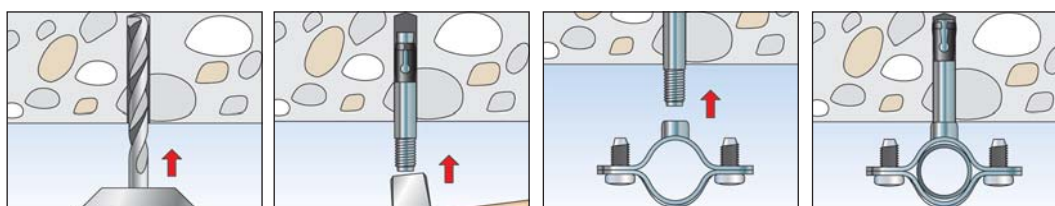

TECHNICAL DATA



Metal two-piece pipe clamp **AM**

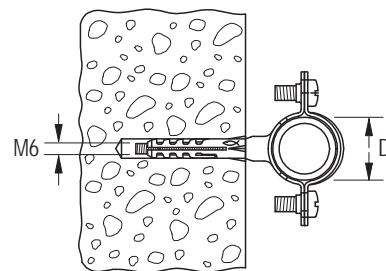

Item	Art.-No.	Dimension IEC	Clamping range D [mm]	Sales unit [pcs]				
AM 8	060185	–	8	50				
AM 10	060186	–	10	50				
AM 12	060187	12	12	50				
AM 14	060188	–	14	50				
AM 16	060189	16	16	50				
AM 18	060190	–	18	50				
AM 20	060191	20	20	50				
AM 22	060192	–	22	50				
AM 24	060193	–	24	50				
AM 26	060194	25	25 - 26	50				
AM 28	060195	–	28	50				
AM 30	060196	–	30	50				
AM 32	060209	32	32	25				
AM 34	060210	–	34	25				
AM 37	060211	37	37	20				
AM 40	090849	40	40	15				
AM 50	090850	50	50	10				

The flat metal clip for cables and pipes



Fixing armoured conduits



Fixing armoured conduits

BUILDING MATERIALS

When using impact nail ED:

- Concrete

ADVANTAGES

- The open conduit clip BSM is ideal for the post-installation fixing of conduits.
- The conduit clip allows for a direct fixing with impact nails and is, therefore, quick and easy to install.
- Two conduits or pipes can be fixed with just one fixing point with the twin clamp BSMZ.

APPLICATIONS

For fixing of:

- Electrical conduits
- Flexible and rigid plastic insulating pipes
- Steel conduits

FUNCTIONING

- Depending on your requirements, use a conduit clip with 1 or 2 fixing points, or a twin clamp.
- The conduits or pipes are laid in the conduit clip. Assembling the clip fixes the conduits / pipes.
- Our recommendation for fixtures on concrete: Impact nail ED 15, 18, 22.

12

Electrical fixings

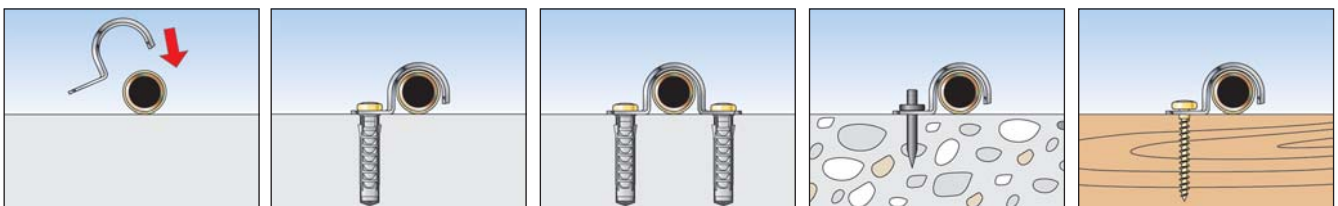

TECHNICAL DATA



Conduit clip **BSM**



Conduit clip **BSMD**



Conduit clip **BSMZ**

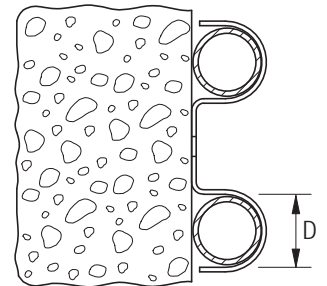
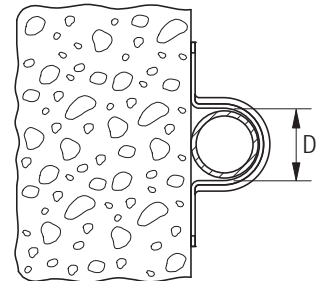
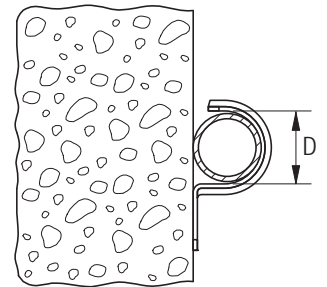

Item	Art.-No.			Dimension IEC	Clamping range D [mm]	Sales unit [pcs]	
	BSM	BSMD	BSMZ				
6	015014	—	—	—	6	100	
8	015015	—	—	—	8	100	
10	015016	—	—	—	10	100	
10	—	015068	—	—	10	50	
12	—	015069	—	—	12	50	
14	—	015070	—	—	14	50	
16	060149	060169	—	16	16	50	
18	060150	060170	—	—	18	50	
20	060151	060171	079535	20	20	50	
22	060152	060172	—	—	22	50	
24	060153	—	079536	—	24	50	
25	090839	090844	—	25	25	50	
26	096958	015076	—	—	26	50	
28	060155	—	079537	—	28	50	
28	—	060175	—	—	28	25	
30	015019	—	—	—	30	50	
32	090840	—	—	32	32	50	
32	—	090845	—	32	32	25	
37	060158	060178	—	—	37	25	
40	090841	090846	—	40	40	25	
42	—	015081	—	—	42	20	
47	—	015082	—	—	47	20	
50	090842	—	—	50	50	20	
50	—	090847	—	50	50	15	
63	—	090848	—	63	63	10	
63	090843	—	—	63	63	15	

Fixing in concrete without pre-drilling



BUILDING MATERIALS

- Concrete

ADVANTAGES

- The stable impact nail ED can be set in concrete with the impact nail setting tool SZE without pre-drilling. This allows for a fast installation.
- The setting tool SZE impact protection provides the best protection for your hand, thus ensuring a safe installation.

APPLICATIONS

For fixing of:

- Conduit clips such as BSM, BSMD, BSMZ
- Perforated band such as LBK, LBV

FUNCTIONING

- The impact nail ED is set in the setting tool SZE.
- The bracket in the setting tool holds the nail securely in place during the installation procedure.
- The nail can then be directly hit into the concrete.

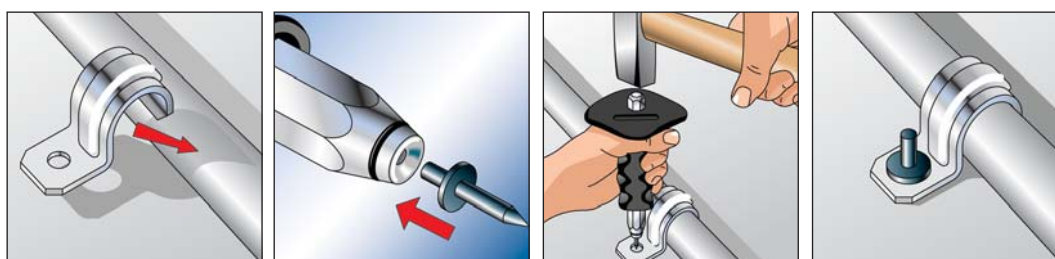

TECHNICAL DATA



Impact nail ED

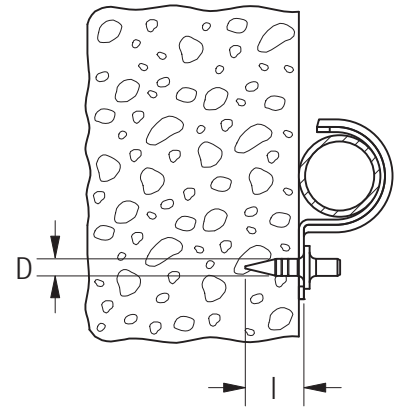

Item	Art.-No.	Length		Diameter		Sales unit					
		l	D	D	D	[pcs]					
ED 15	048212	15	4,0	4,0	4,0	200					
ED 18	079815	18	4,0	4,0	4,0	200					
ED 22	014570	22	4,0	4,0	4,0	200					

TECHNICAL DATA



Impact nail setting tool SZE

Toolset for SZE

Item	Art.-No.	Sales unit								
		[pcs]								
SZE	079820	1								
Toolset for SZE	043365	4								

For the simple bundling of cables and pipes

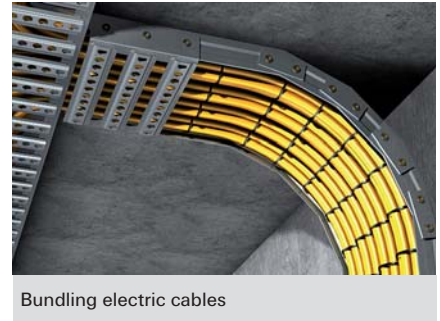

CHARACTERISTICS



12

Electrical fixings

ADVANTAGES

- The long-lasting nylon material is halogen- and silicone-free.
- The cable tie UBN (black) is made from UV-stabilised material, and is therefore particularly suited to use in exterior areas.

APPLICATIONS

- For bundling of:**
- Electric cables
 - Flexible and rigid plastic insulating pipes
 - Steel conduits

FUNCTIONING

- Lie the cable tie around the object to be fixed, and pull the band through the head of the cable tie. The cable tie can no longer be opened due to the latching of the tab in the teeth.
- Temperature resistance once installed from -40 °C to +80 °C.
- Recommended processing temperature up to -25 °C.

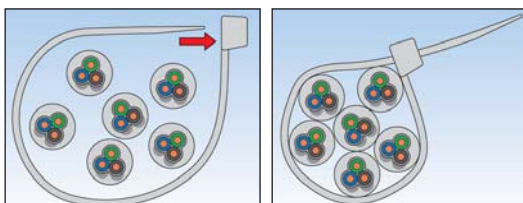

TECHNICAL DATA

 Cable tie **BN**, colour: transparent

 Cable tie **UBN**, colour: black

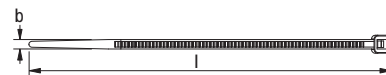

Item	Colour: black	Colour: transparent	Dimensions b x l [mm]	Sales unit	Outer carton				
				[pcs]	[pcs]				
BN/UBN 2,5 x 100	087488	087478	2,5 x 100	100	20000				
BN/UBN 2,5 x 120	087489	087479	2,5 x 120	100	15000				
BN/UBN 2,5 x 200	087490	087480	2,5 x 200	100	10000				
BN/UBN 3,6 x 150	087491	087481	3,6 x 150	100	10000				
BN/UBN 3,6 x 200	037573	019802	3,6 x 200	100	10000				
BN/UBN 3,6 x 300	069364	037490	3,6 x 300	100	7500				
BN/UBN 4,6 x 200	087494	087484	4,6 x 200	100	7500				
BN/UBN 4,8 x 250	069367	037582	4,8 x 250	100	5000				
BN/UBN 4,8 x 280	087495	087485	4,8 x 280	100	5000				
BN/UBN 4,8 x 350	069368	037653	4,8 x 350	100	5000				
BN/UBN 4,8 x 370	069369	037583	4,8 x 370	100	8000				
BN/UBN 4,8 x 430	069370	037708	4,8 x 430	100	5000				
BN/UBN 7,6 x 350	087497	087487	7,6 x 350	100	2500				
BN/UBN 7,6 x 450	069374	037996	7,6 x 450	100	2500				
BN/UBN 7,6 x 550	069375	037997	7,6 x 550	100	2000				
BN/UBN 8,8 x 760	069376	037998	8,8 x 760	100	1800				
BN/UBN 8,8 x 810	069377	038000	8,8 x 810	100	1500				
BN/UBN 8,8 x 1168	069379	038002	8,8 x 1168	100	800				

Infinitely variable fixing of wire suspensions



ADVANTAGES

- The simple system, comprising wire and Wireclip, guarantees ease of use.
- The Wireclip's simple closing mechanism means that no tools are needed. This allows for a cost-effective installation.
- The reclosable Wireclips make it possible to adjust the length at any time. This guarantees the greatest flexibility.

APPLICATIONS

- For fixing of:**
- Lighting strips
 - Cable trays
 - Busbars
 - Ventilation ducts
 - Pipes
 - Signs
 - Chilled ceilings

FUNCTIONING

- Loops are formed from the wire, which can be threaded through the Wireclips. This allows objects to be hung. The Wireclips can be adjusted at any time.
- The FNA II 6x25 OE is suitable for fixing the wire.

Note:

- Do not apply paint or any other coating.
- Do not apply lubricant.
- Do not use for lifting loads.
- Remove damaged wire ends using the wire cutter WIZ prior to introducing wires into the Wireclip.

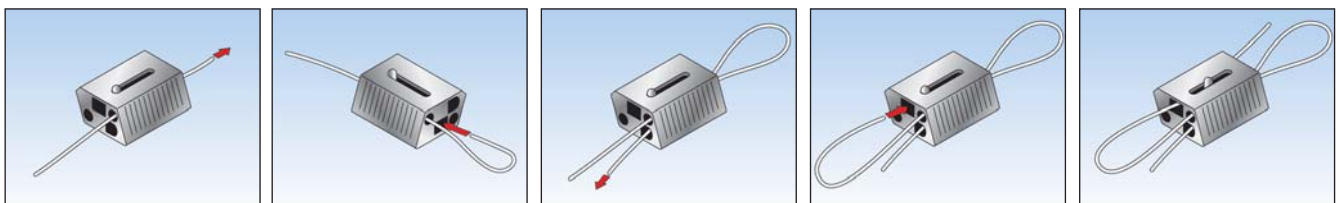

TECHNICAL DATA

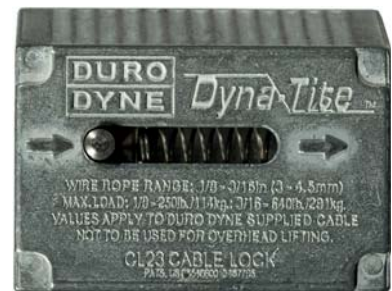

WIC 2

WIC 3

WIC 4

Item	Art.-No.	Wire-Ø [mm]	Sales unit [pcs]					
WIC 2 VE20	044559	2 - 2,5	20					
WIC 3 VE20	044561	2,5 - 3,5	20					
WIC 2 VE100	044560	2 - 2,5	100					
WIC 4 VE50	044564	3 - 4	50					

TECHNICAL DATA



WIS cable set with eyelet

Wire cutter WIZ

Item	Art.-No.	Cable length [m]	Wire-Ø [mm]	Sales unit [pcs]				
WIS 2/1	045956	1	2	10				
WIS 2/2	045957	2	2	10				
WIS 2/3	045958	3	2	10				
WIS 2/5	045959	5	2	10				
WIS 2/10	045960	10	2	10				
WI Ø 2 mm	044565 ¹⁾	200	2	1				
WIZ	044721	–	–	1				

¹⁾ on a roll

LOADS

Wireclip

Highest recommended loads¹⁾ for each Wireclip.

Type	Diameter of wire cable		Recommended tensile load	
	[mm]		[kN]	
WIS complete system ²⁾	2		0,5	
WIC 2 ²⁾	2		0,6	
WIC 2 ²⁾	2,5		1,0	
WIC 3 ²⁾	3		1,2	
WIC 4 ²⁾	4		2,3	

¹⁾ Includes the safety factor 5.

²⁾ Only in combination with fischer wire cable.

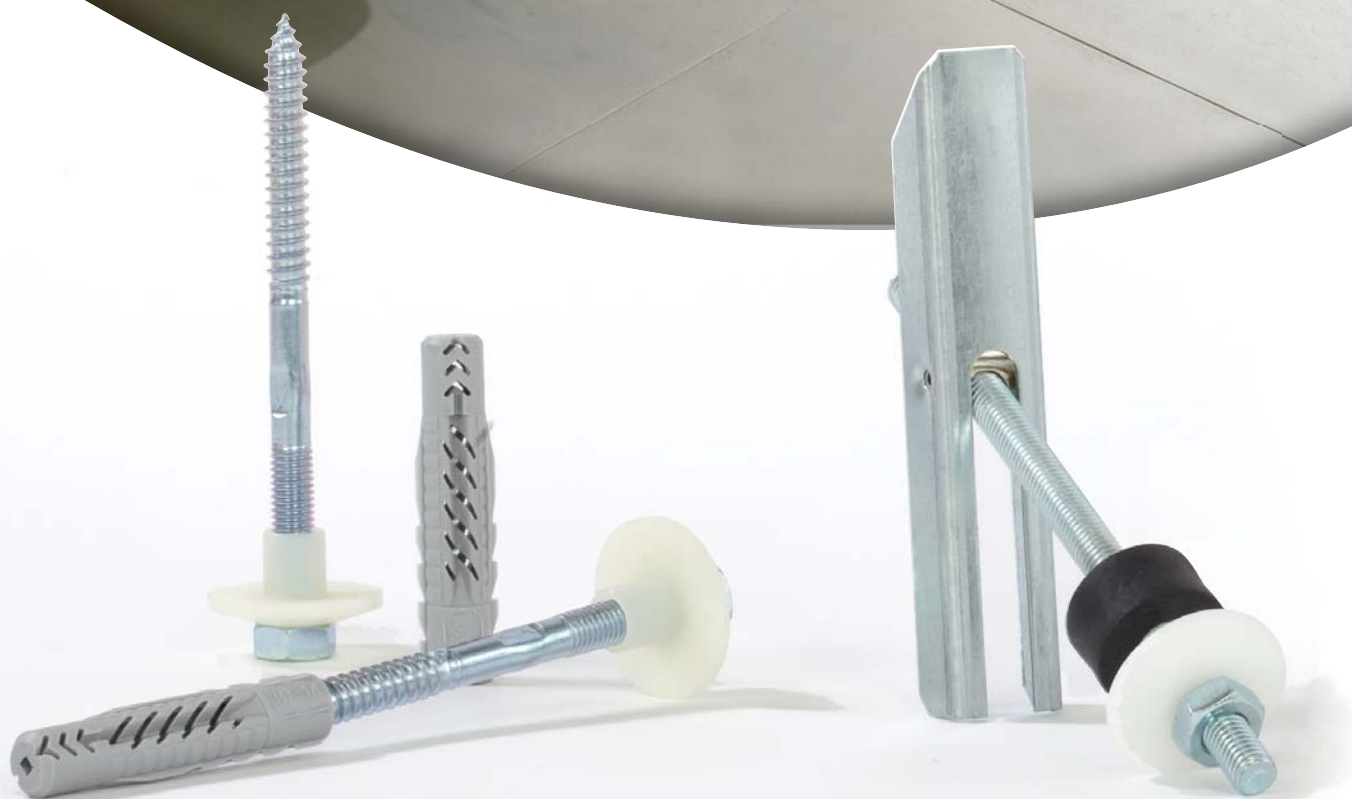

13

Sanitary fixings

	page
Sanitary fixings for board materials	288
Ceramic fixings	290
Thermal insulation blocks	292

Complete fixing sets for wash basins and urinals in board building materials and plumbing walls



BUILDING MATERIALS

- Gypsum plasterboard and gypsum fibreboards
- Chipboard

ADVANTAGES

- With their special geometries, KM and WDP are the specialists for fixings in plumbing and hollow walls.
- The wide transition beams of the KM and the large base plate of the WDP ensure a good load distribution, thus allowing for a high load-bearing capacity.

APPLICATIONS

- Wash basins
- Urinals

FUNCTIONING

- KM is suitable for push-through installation.
- When placed in the drill hole, the wide transition beam of the KM independently swings open behind the board.
- WDP is set into the plumbing walls during wall installation.

13

Sanitary fixings

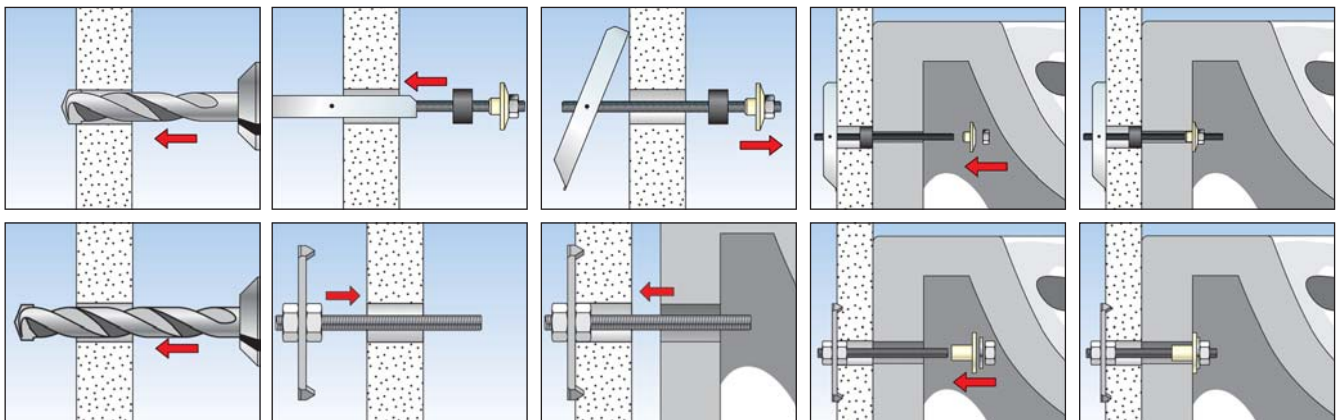

TECHNICAL DATA



Wash basin and urinal fixing **WDP**

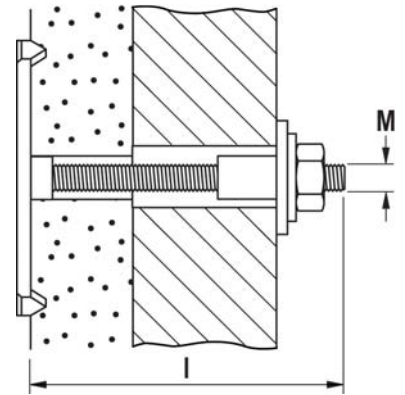

Item	Art.-No.	Thread M	Length l [mm]	Sales unit [pcs]				
WDP 10 x 170	014320	M 10	170	10				

TECHNICAL DATA

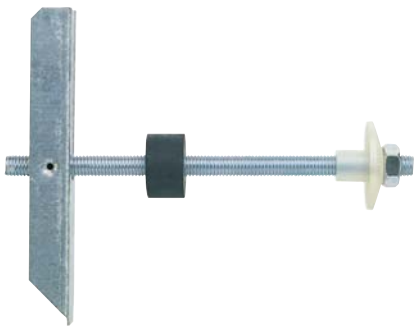

Gravity toggle **KM 10**

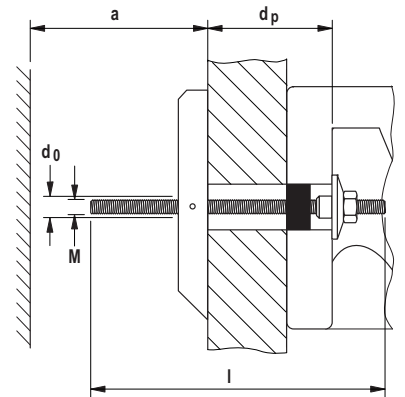

Item	Art.-No.	Drill hole diameter d_0 [mm]	Anchor length l [mm]	Min. cavity depth a [mm]	Max. panel thickness d_p [mm]	Screw $d_s \times l_s$ [mm]	Sales unit [pcs]
KM 10	050326	30	180	140	90	M 10 x 180	25

Complete fixing sets for free-standing toilets and bidets



Free-standing toilets



Bidets

BUILDING MATERIALS

- Concrete
- Solid sand-lime brick
- Natural stone with dense structure
- Solid brick made from lightweight concrete
- Solid brick

CHARACTERISTICS



ADVANTAGES

- Complete fixing sets including brass screws allow for quick and easy installation.
- A pronounced rim prevents contact between the screw and ceramics, thus ensuring nothing gets damaged during fixing.
- The WB5N's assembly bracket with pre-drilled rows of holes allows for a flexible fixing with two directions.
- The WCN is also suitable for fixing ceramic shelves and mirrors, and can thus be used for a wide range of applications.

APPLICATIONS

- Free-standing toilets
- Bidets
- Ceramic shelves
- Mirrors

FUNCTIONING

- S 8 RD is suitable for push-through installation.
- WCN and S 8 D are suitable for both pre-positioned and push-through installation.
- The WB5N's assembly bracket is flexibly positioned on the base using the long hole. The ceramics are then fixed to the bracket via the rows of holes. These counterbalance any height differences in the ceramic assembly holes.

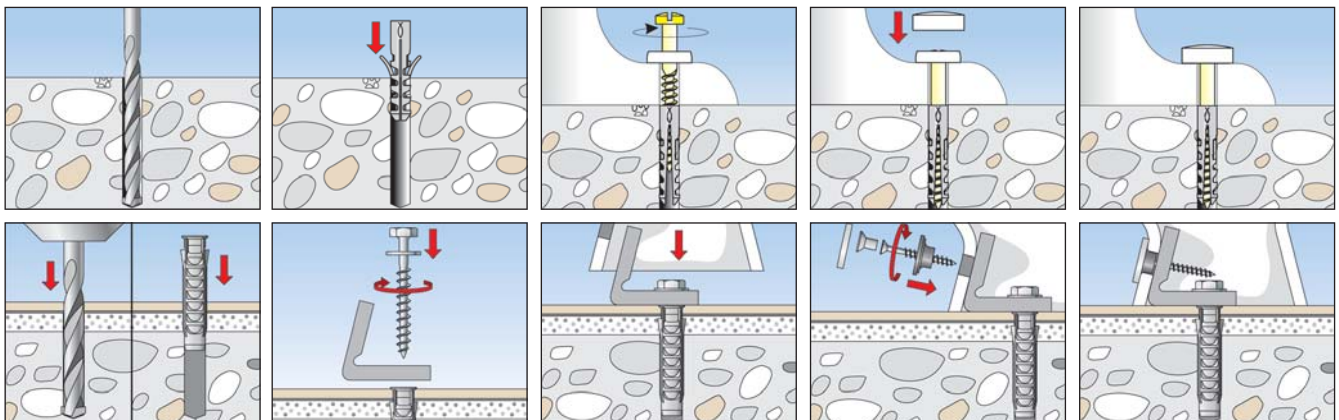

TECHNICAL DATA



WCN

Item	Art.-No.	Contents per plastic bag	Sales unit
		[pcs]	[pcs]
WCN 1	060561	2 wall plugs S 8, 2 brass screws 6 x 70 6kt., 2 cover caps white, 2 snap-fit sleeves	50
WCN 2	060562	2 wall plugs S 8, 2 brass screws 6 x 70 6kt., 2 cover caps chrome, 2 snap-fit sleeves	50

TECHNICAL DATA



S 8 D 70 WCR

Item	Art.-No.	Contents per plastic bag	Sales unit
		[pcs]	[pcs]
S 8 D 70 WCR	060564	2 wall plugs S 8, 2 brass screws 6 x 70 6kt., 2 cover caps chrome and white, 2 snap-fit sleeves	50

TECHNICAL DATA



S 8 RD WCR

Item	Art.-No.	Contents per plastic bag	Sales unit
		[pcs]	[pcs]
S 8 RD 60 WCR	060570	2 wall plugs S 8 RD 60, 2 brass screws 6 x 65 6kt., 2 cover caps chrome and white	50
S 8 RD 80 WCR	060568	2 wall plugs S 8 RD 80, 2 brass screws 6 x 85 6kt., 2 cover caps chrome and white	50

TECHNICAL DATA



WC fixing **WB 5N**

Item	Art.-No.	Contents	Sales unit
			[pcs]
WB 5N	018652	2 S plugs SX 10, 2 Screws 7x65 zinc-plated, 2 Nylon angles, 2 washers 8mm, 2 screws A2 stainless steel, 2 flanged sleeves, 2 cover caps chrom	50

Complete fixing sets for wash basins, urinals and sanitary installations



Urinals



Wash basins

BUILDING MATERIALS

- Concrete
- Vertically perforated brick
- Hollow blocks made from lightweight concrete
- Perforated sand-lime brick
- Solid sand-lime brick
- Natural stone
- Aerated concrete
- Solid panel made from gypsum
- Solid brick made from lightweight concrete
- Solid brick

CHARACTERISTICS



ADVANTAGES

- Complete fixing sets allow for quick and easy installation.
- The universal plug UX can be used in solid and hollow materials, thus offering a high level of flexibility.
- Flanged nuts and collar sleeves made of high-strength nylon are resistant to ageing and chemicals, and guarantee a long-lasting fixing that will not damage the ceramics.
- Cover caps with a high-quality chrome finish ensure the fixture remains visually attractive for a long period of time.

APPLICATIONS

- Wash basins
- Urinals
- Built-in toilets
- Boilers
- Gas heaters
- Cisterns
- Consoles

FUNCTIONING

- The rimless UX is suitable for pre-positioned and push-through installation.
- Screwing in the screw causes the UX to expand in solid and hollow building material.
- Maximum load-bearing capacity is only achieved when the minimum screw-in depth is reached.
- Tiles and plaster are not classed as load-bearing base materials.

13

Sanitary fixings

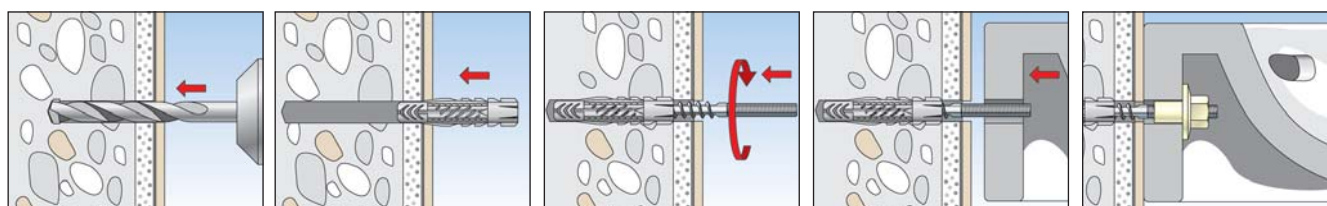

TECHNICAL DATA



Wash basin and urinal fixing **WD**

Item	Art.-No.	Contents per plastic bag	Sales unit
		[pcs]	[pcs]
WD 8 x 90	080659	2 wall plugs UX 10 x 60, 2 stud screws M8 x 90 zinc-plated, 2 flanged nuts BU M8	50
WD 8 x 110	080658	2 wall plugs UX 10 x 60, 2 stud screws M8 x 110 zinc-plated, 2 flanged nuts BU M8	50
WD 10 x 120	080655	2 wall plugs UX 14 x 75, 2 stud screws M10 x 120 zinc-plated, 2 flanged nuts BU M10 MH	50
WD 10 x 140	080656	2 wall plugs UX 14 x 75, 2 stud screws M10 x 140 zinc-plated, 2 flanged nuts BU M10 MH	50

TECHNICAL DATA



Boiler fixing **BO**

Item	Art.-No.	Contents per plastic bag	Sales unit
		[pcs]	[pcs]
BO 120	080654	4 wall plugs UX 14 x 75, 4 stud screws M10 x 120 zinc-plated, 4 flanged nuts BU M10	25

TECHNICAL DATA



Washbasin fixing **WST**

Item	Art.-No.	Contents per plastic bag	Sales unit
		[pcs]	[pcs]
WST 10 x 140	080660	2 wall plugs UX 14 x 75, 2 stud screws M10 x 140 zinc-plated, 2 hexagon nuts M10 zinc-plated, 2 flanged bushes BDH M10	50
WST 12 x 150	080661	2 wall plugs UX 14 x 75, 2 stud screws M12 x 150 zinc-plated, 2 hexagon nuts M12 zinc-plated, 2 flanged bushes BDH M12	50
WST 12 x 180	080662	2 wall plugs UX 14 x 75, 2 stud screws M12 x 180 zinc-plated, 2 hexagon nuts M12 zinc-plated, 2 flanged bushes BDH M12	50

TECHNICAL DATA



Urinal fixing **UST 8 x 110**



Urinal fixing **UST 10 x 120**

Item	Art.-No.	Contents per plastic bag	Sales unit
		[pcs]	[pcs]
UST 8 x 110	083578	2 wall plugs UX 10 x 60, 2 stud screws M8 x 110, 2 washers B 8.4 DIN 125, 2 plastic washer 8,4 x 16 x 1,6, 2 cap nuts FA 8, 2 cover caps chrome plated	50
UST 10 x 120	080668	2 wall plugs UX 14 x 75, 2 stud screws M10 x 120, 2 flanged nuts BU M10, 2 cover caps AKM 10 CR	10

TECHNICAL DATA



Sanitary fixing **WL**

Item	Art.-No.	Contents per plastic bag	Sales unit
		[pcs]	[pcs]
WL 7 x 60	080651	2 wall plugs UX 10, 2 screws 7 x 65 hex. head zinc-plated, 2 washers zinc-plated	100
WL 8 x 70	080652	2 wall plugs UX 10, 2 screws 8 x 70 6kt. DIN 571 zinc-plated, 2 washers zinc-plated	100
WL 10 x 80	080650	2 wall plugs UX 12, 2 screws 10 x 80 6kt. DIN 571 zinc-plated, 2 washers zinc-plated	50

ACCESSORIES



Flanged nut **BUM**

Item	Art.-No.	Thread	Width across nut	Washer	Match	Sales unit		
		M	○SW [mm]	[mm]		[pcs]		
BU M8 MH	060200	M 8	17	40	STS M8	25		
BU M10 MH	060201	M 10	17	40	STS M10	25		
BU M12 MH	060204	M 12	19	40	STS M12	25		

ACCESSORIES



Cover cap **AKM**

Item	Art.-No.	Colour	Match	Sales unit				
				[pcs]				
AKM 10 W	080972	white	BU M10 MH	20				
AKM 10 CR	080951	chrome	BU M10 MH	100				
AKM 12 CR	080952	chrome	BU M12 MH	100				

ACCESSORIES



Installation tool **HED**

Item	Art.-No.	Match	Sales unit
			[pcs]
HED	079831	M6, M8, M10, M12	1

INSTALLATION DATA

Item	Art.-No.	Drill diameter	Min. drill hole depth	Usable length (with assembled flanged nut)	Min. bolt penetration
		d_0 [mm]	h_1 [mm]	t_{fix} [mm]	$l_{E,min}$ [mm]
WD 8 x 90	080659	10	75	5	68
WD 8 x 110	080658	10	75	25	68
WD 10 x 120	080655	14	95	18	85
WD 10 x 140	080656	14	95	38	85
BO 120	080654	14	95	18	85
WST 10 x 140	080660	14	95	38	85
WST 12 x 150	080661	14	95	48	85
WST 12 x 180	080662	14	95	78	85
UST 8 x 110	083578	10	75	32	68
UST 10 x 120	080668	14	95	18	85
WL 7 x 60	080651	10	70	10	57
WL 8 x 70	080652	10	70	12	58
WL 10 x 80	080650	12	80	10	70

LOADS

Washbasin and urinal fixings

Highest recommended loads¹⁾ for a single anchor.

The given loads are valid when the provided screws with the specified diameter are used.

Type		WD 8x90 WD 8x110	WD 10x120 WD 10x140	WST 10x140 BO 120	WST 12x150 WST 12x180	UST 8x110	UST 10x120	WL 7x60	WL 8x70	WL 10x80	
Screw diameter	\emptyset [mm]	8	10	10	12	8	10	7	8	10	
Recommended loads in the respective base material F_{rec}²⁾											
Concrete	\geq C20/25	[kN]	0,90	0,90	0,90	1,80	0,90	0,90	1,10	1,10	1,50
Solid brick	\geq Mz12	[kN]	0,50	0,50	0,50	0,80	0,50	0,50	³⁾	³⁾	³⁾
Perforated sand-lime brick	\geq KSL12	[kN]	0,40	0,40	0,40	0,80	0,40	0,40			
Vertically perforated brick	\geq Hlz 12	[kN]	0,20	0,30	0,30	0,40	0,20	0,30			
Aerated concrete	\geq PB4, PP4 (G4)	[kN]	0,30	0,30	0,30	0,70	0,30	0,30	0,16	0,16	0,28

¹⁾ Includes the safety factor 7.













²⁾ Valid for tensile load, shear load and oblique load under any angle.

³⁾ Due to that the failure of the substrate varies too much no reproducible values can be given.







14

Plugs and anchors

	page		page		page	
High performance steel anchors						
Bolt anchor FAZ II 	301	Injection mortar FIS V 	317	2-component fixing foam 2K PU S 400 	328	
ZYKON undercut anchor FZA 	304	Injection mortar FIS VL 	320	Premium sanitary silicone DSSA 	329	
ZYKON hammerset anchor FZEA II 	305	Plastic fixings				
Concrete screw FBS II / FBS 	305	Frame fixing SXR 	321	Premium construction silicone DBSA 	329	
Hammerset anchor EA II 	309	Frame fixing SXRL 	322	Construction sealant Premium DKM 	330	
Nail anchor FNA II 	310	Stand-off installation Thermax 	323	Premium all-weather sealant DDK 	330	
Ceiling nail FDN 	311	DUOPOWER 	325	All-round adhesive gluing and sealing KD 	330	
Aircrete anchor FPX-I 	312	Universal plug UX 	326	Zinc Spray FTC-ZS 	331	
Chemical fixings						
Highbond-System FHB II 	313	Expansion plug SX 	327	Accessories 	331	
Superbond-System FSB 	316	Foams and sealants				
One-component gun foam PUP BS 750 						328
2-component rapid foam 2K PU 400 						328

1.1 Overview of anchors and their approvals or suitability for sprinkler installations

Typ						
	ETA Concrete single	ETA Beton Concrete multiple	ETA Masonry			
FAZ II	Option 1				✓	✓
FBS, ULTRACUT FBSII	Option 1	✓ (FBS 6)			✓ (incl. FBS 6)	
FZA	Option 1				✓	✓
FHB II	Option 1					
FZEA II	Option 1				✓	✓
EA II	Option 7	✓			✓	✓
FIS V/VS/VW	Option 1		✓			
FIS SB	Option 1					
FIS V	Option 1		✓			
FNA II		✓			✓	
FPX-I			✓ Aerated concrete		✓ Aerated concrete	
FDN		✓				
SXR(L)		✓	✓			















Legende:

ETA concrete option 1, single fixing = suitable for cracked and uncracked concrete

ETA concrete option 7, single fixing = suitable for uncracked concrete

ETA concrete for multiple fixing = suitable for cracked and uncracked concrete

1.2 Anchor recommendation for fixing of Installation systems -products

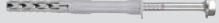













SaMontec products for push-through	 Plugs recommendation for concrete substrate	 Plugs recommendation for masonry substrate
<p>FCA</p>  <p>FUS</p>  <p>VB</p> 	<p>FAZ II</p>  <p>FBS, ULTRACUT FBSII</p> 	<p>SXR (L)</p>  <p>FIS V With threaded rod or internal threaded socket as an alternative for pre positional installation.</p>  
<p>FLS</p>  <p>GPL</p> 	<p>FBS 6</p>  <p>FDN</p>  <p>FNA II</p> 	<p>SXR(L)</p>  <p>As an alternative for pre-positioned installation!</p>

Push-through installation:

Drilling of the hole as well as the installation of the anchor takes place through the baseplate of the cantilever arm, the channel or saddle flange, ...

Note: The combination of SaMontec products and anchors is variable.

1.2 Anchor recommendation for fixing of Installation systems -products

SaMontec products push-through installation	 Plugs recommendation for concrete substrate	 Plugs recommendation for masonry substrate	
<p>G/GS</p>  <p>Pipe clamp</p> 	<p>EA II</p>  <p>FZEA II</p>  <p>FBS M6/M8</p> 	<p>FPX-I for aerated concrete</p>  <p>FIS V with threaded rod or internal threaded socket as an alternative for pre positional installation.</p>   	<p>UX</p>  <p>SX</p>  <p>DUOPOWER</p> 

Pre positioned installation:

Drilling and anchor installation is done before installing (if required by screwing in) of the accessory like threaded rod or pipe clamps, ...

Note: The combination of SaMontec products and anchors is variable.

For further details as loads and dimensions please see the following pages or www.fischer.com

Bolt anchor FAZ II

For highest demands. Powerful and flexible.

TECHNICAL DATA



Bolt anchor FAZ II

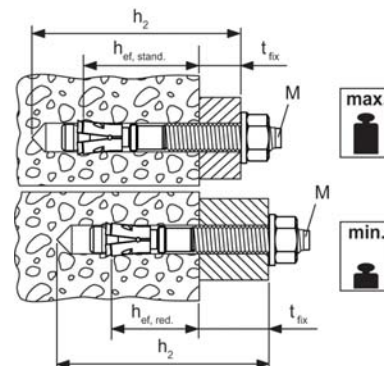

Item	zinc-plated steel	stainless steel	highly corrosion resistant steel	Approval		Seismic-Approval	Drill hole diameter	Min. drill hole depth for through fixings	Anchor length	Max. usable length hef,stand/hef,red	Thread	Width across nut	Sales unit
	Art.-No.	Art.-No.	Art.-No.	ETA	ICC		d_0 [mm]	h_2 [mm]	l [mm]	t_{fix} [mm]	$\emptyset \times$ length [mm]	\emptyset SW [mm]	[pcs]
FAZ II 8/10	094871	501396	—	■	▲	C1	8	65	75	10/20	M 8 x 38	13	50
FAZ II 8/10	—	—	501428	■	▲	C1	8	65	75	10/20	M 8 x 38	13	10
FAZ II 8/30	094877	501399	—	■	▲	C1	8	85	95	30/40	M 8 x 58	13	50
FAZ II 8/30	—	—	501429	■	▲	C1	8	85	95	30/40	M 8 x 58	13	10
FAZ II 8/50	094878	501401	—	■	▲	C1	8	105	115	50/60	M 8 x 78	13	50
FAZ II 8/100	094879	—	—	■	▲	C1	8	155	165	100/110	M 8 x 128	13	25
FAZ II 8/160	503251	—	—	■	▲	C1	8	215	225	160/170	M 8 x 100	13	20
FAZ II 10/10	094981	501403	—	■	▲	C1 / C2	10	85	95	10/30	M 10 x 53	17	50
FAZ II 10/10	—	—	501430	■	▲	C1	10	85	95	10/30	M 10 x 53	17	10
FAZ II 10/20	094982	—	—	■	▲	C1 / C2	10	95	105	20/40	M 10 x 63	17	25
FAZ II 10/20	—	501406	—	■	▲	C1 / C2	10	95	105	20/40	M 10 x 63	17	50
FAZ II 10/30	094983	—	—	■	▲	C1 / C2	10	105	115	30/50	M 10 x 73	17	25
FAZ II 10/30	—	501407	—	■	▲	C1 / C2	10	105	115	30/50	M 10 x 73	17	50
FAZ II 10/30	—	—	503185	■	▲	C1	10	105	115	30/50	M 10 x 73	17	10
FAZ II 10/50	094984	501409	—	■	▲	C1 / C2	10	125	135	50/70	M 10 x 93	17	20
FAZ II 10/70	—	501410	—	■	▲	C1 / C2	10	145	155	70/90	M 10 x 113	17	20
FAZ II 10/80	094985	—	—	■	▲	C1 / C2	10	155	165	80/100	M 10 x 123	17	20
FAZ II 10/100	—	501411	—	■	▲	C1 / C2	10	175	185	100/120	M 10 x 100	17	20
FAZ II 10/100	094986	—	—	■	▲	C1 / C2	10	175	185	100/120	M 10 x 143	17	20
FAZ II 10/160	—	501412	—	■	▲	—	10	235	245	160/180	M 10 x 100	17	20
FAZ II 10/160	503252	—	—	■	▲	—	10	235	245	160/180	M 10 x 193	17	20
FAZ II 12/10	095419	501413	—	■	▲	C1 / C2	12	100	110	10/30	M 12 x 61	19	20
FAZ II 12/10	—	—	503186	■	▲	C1	12	100	110	10/30	M 12 x 61	19	10
FAZ II 12/20	095420	501415	—	■	▲	C1 / C2	12	110	120	20/40	M 12 x 71	19	20
FAZ II 12/30	095421	501416	—	■	▲	C1 / C2	12	120	130	30/50	M 12 x 81	19	20
FAZ II 12/30	—	—	501431	■	▲	C1	12	120	130	30/50	M 12 x 81	19	10
FAZ II 12/50	095446	501419	—	■	▲	C1 / C2	12	140	150	50/70	M 12 x 101	19	20
FAZ II 12/60	—	501420	—	■	▲	C1 / C2	12	150	160	60/80	M 12 x 111	19	20
FAZ II 12/80	095454	—	—	■	▲	C1 / C2	12	170	180	80/100	M 12 x 131	19	20
FAZ II 12/100	095470	501421	—	■	▲	C1 / C2	12	190	200	100/120	M 12 x 151	19	20
FAZ II 12/160	503253	—	—	■	▲	—	12	250	260	160/180	M 12 x 186	19	10
FAZ II 12/160	—	503180	—	■	▲	—	12	250	260	160/180	M 12 x 100	19	20
FAZ II 12/200	095605	—	—	■	▲	—	12	290	300	200/220	M 12 x 186	19	10
FAZ II 16/5	522124	—	—	■	▲	C1 / C2	16	115	128	5/25	M 16 x 64	24	20
FAZ II 16/5	—	522125	—	■	▲	C1 / C2	16	115	128	5/25	M 16 x 64	24	10
FAZ II 16/25	—	501423	—	■	▲	C1 / C2	16	135	148	25/45	M 16 x 84	24	20
FAZ II 16/25	—	—	501432	■	▲	C1	16	135	148	25/45	M 16 x 84	24	10
FAZ II 16/25	095836	—	—	■	▲	C1 / C2	16	135	148	25/45	M 16 x 84	24	10
FAZ II 16/50	095864	—	—	■	▲	C1 / C2	16	160	173	50/70	M 16 x 109	24	10

TECHNICAL DATA



Bolt anchor **FAZ II**

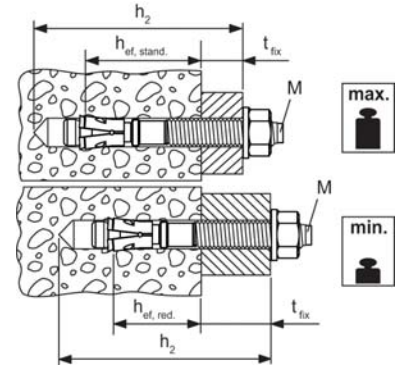

Item	zinc-plated steel	stainless steel	highly corrosion resistant steel	Approval		Seismic-Approval	Drill hole diameter	Min. drill hole depth for through fixings	Anchor length	Max. usable length hef,stand/hef,red	Thread	Width across nut	Sales unit
	Art.-No.	Art.-No.	Art.-No.	ETA	ICC		d_0 [mm]	h_2 [mm]	l [mm]	t_{fix} [mm]	$\emptyset \times$ length [mm]	\emptyset SW [mm]	[pcs]
FAZ II 16/50	—	—	503187	■	▲	C1	16	160	173	50/70	M 16 x 109	24	10
FAZ II 16/50	—	501424	—	■	▲	C1 / C2	16	160	173	50/70	M 16 x 109	24	20
FAZ II 16/100	095865	501425	—	■	▲	C1 / C2	16	210	223	100/120	M 16 x 159	24	10
FAZ II 16/160	503254	—	—	■	▲	C1 / C2	16	270	283	160/180	M 16 x 189	24	10
FAZ II 16/200	095967	—	—	■	▲	—	16	310	323	200/220	M 16 x 189	24	10
FAZ II 16/250	095968	—	—	■	▲	—	16	360	373	250/270	M 16 x 100	24	10
FAZ II 16/300	096188	—	—	■	▲	—	16	410	423	300/320	M 16 x 100	24	10
FAZ II 20/30	046632	—	—	■	▲	C1 / C2	20	155	172	30/-	M 20 x 54	30	5
FAZ II 20/30	—	501426	—	■	▲	C1 / C2	20	155	172	30/-	M 20 x 54	30	4
FAZ II 20/60	046633	—	—	■	▲	C1 / C2	20	185	202	60/-	M 20 x 84	30	5
FAZ II 20/60	—	503183	—	■	▲	C1 / C2	20	185	202	60/-	M 20 x 84	30	4
FAZ II 20/160	503255	—	—	■	▲	C1 / C2	20	285	302	160/-	M 20 x 100	30	5
FAZ II 24/30	046635	—	—	■	▲	C1	24	185	205	30/-	M 24 x 58	36	5
FAZ II 24/30	—	501427	—	■	▲	C1	24	185	205	30/-	M 24 x 58	36	4
FAZ II 24/60	046636	—	—	■	▲	C1	24	215	235	60/-	M 24 x 88	36	5
FAZ II 24/60	—	503184	—	■	▲	C1	24	215	235	60/-	M 24 x 88	36	4

Bolt anchor FAZ II K For highest demands. Short and practible.

TECHNICAL DATA



Bolt anchor **FAZ II K**

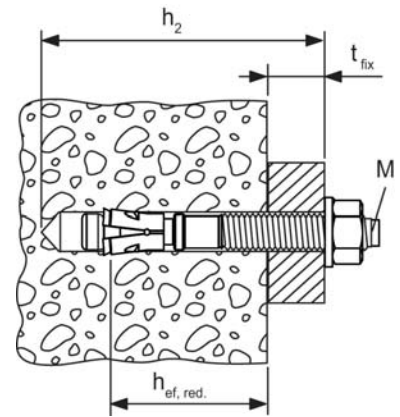

	zinc-plated steel	stainless steel	Approval	Drill hole diameter	Min. drill hole depth for through fixings	Anchor length	Usable length (hef red.)	Thread	Washer (outer diameter x thickness)	Sales unit
	Art.-No.	Art.-No.	ETA	d_0 [mm]	h_2 [mm]	l [mm]	t_{fix} [mm]	\emptyset x length [mm]	[mm]	[pcs]
Item	gvz	A4								
FAZ II 8/5 K	538989	538990	■	8	45	60	5	M 8 x 23	16 x 1,6	50
FAZ II 10/10 K	522108	522116	■	10	65	75	10	M 10 x 33	20 x 2	50
FAZ II 10/20 K	522110	—	■	10	75	85	20	M 10 x 43	20 x 2	25
FAZ II 10/20 K	—	522117	■	10	75	85	20	M 10 x 43	20 x 2	50
FAZ II 12/10 K	522118	522122	■	12	80	90	10	M 12 x 41	24 x 2,5	20
FAZ II 12/20 K	522119	522123	■	12	90	100	20	M 12 x 51	24 x 2,5	20
FAZ II 10/10 K GS	522115	—	■	10	65	75	10	M 10 x 33	25 x 3	50
FAZ II 12/10 K GS	522121	—	■	12	80	90	10	M 12 x 41	30 x 3	20

ACCESSORIES



fischer Anchor bolt setting tool **FABS**

Item	Art.-No.	Matching anchor type	Sales unit [pcs]
FABS	077937	FAZ II, FBN II, EXA for diameter from M6 - M12	1

ZYKON undercut anchor FZA

The fixing system with the highest safety in cracked concrete

TECHNICAL DATA



ZYKON Bolt anchor FZA

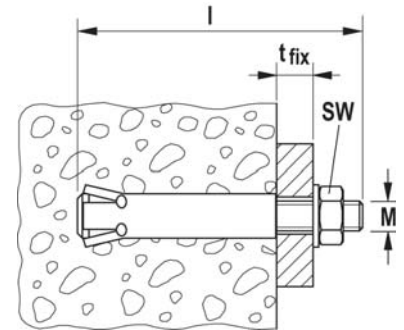

Item	zinc-plated steel	stainless steel	Approval ETA	Seismic-Approval	Required drill bit FZUB	Required setting tool FZE plus	Bolt length l [mm]	Max. fixture thickness t _{fix} [mm]	Thread M	Width across nut ○SW [mm]	Sales unit [pcs]
	Art.-No.	Art.-No.									
	gvz	A4									
FZA 10 x 40 M6/10	060712	060772	■	–	10 x 40	FZE 10 plus	60	10	M 6	10	25
FZA 12 x 40 M 8/15	060715	060775	■	–	12 x 40	FZE 12 plus	69	15	M 8	13	25
FZA 12 x 50 M 8/15	060716	060776	■	–	12 x 50	FZE 12 plus	79	15	M 8	13	20
FZA 12 x 50 M 8/50	–	060774	■	–	12 x 50	FZE 12 plus	114	50	M 8	13	20
FZA 14 x 40 M10/25	060718	–	■	C1	14 x 40	FZE 14 plus	79	25	M 10	17	25
FZA 14 x 40 M10/25	–	060778	■	C1	14 x 40	FZE 14 plus	79	25	M 10	17	20
FZA 14 x 60 M10/25	060719	060779	■	C1	14 x 60	FZE 14 plus	102	25	M 10	17	10
FZA 14 x 60 M10/50	–	060766	■	C1	14 x 60	FZE 14 plus	126	50	M 10	17	10
FZA 18 x 80 M12/25	060721	060781	■	C1	18 x 80	FZE 18 plus	126	25	M 12	19	10
FZA 18 x 80 M12/55	–	060767	■	C1	18 x 80	FZE 18 plus	156	55	M 12	19	10
FZA 22 x 100 M16/60	060724	060782	■	C1	22 x 100	FZE 22 plus	184	60	M 16	24	10
FZA 22 x 125 M16/60	060725	060768	■	C1	22 x 125	FZE 22 plus	209	60	M 16	24	6

TECHNICAL DATA



ZYKON Through anchor FZA-D

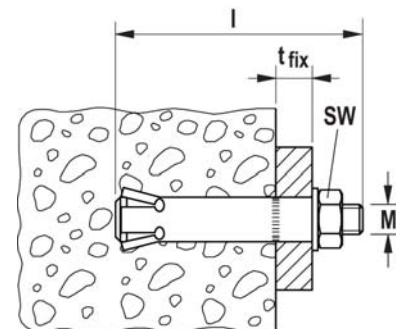

Item	zinc-plated steel	stainless steel	Approval ETA	Seismic-Approval	Required drill bit FZUB	Required setting tool FZE plus	Bolt length l [mm]	Max. fixture thickness t _{fix} [mm]	Thread M	Width across nut ○SW [mm]	Sales unit [pcs]
	Art.-No.	Art.-No.									
	gvz	A4									
FZA 12 x 50 M 8 D/10	060652	060664	■	–	12 x 50	FZE 12 plus	69	10	M 8	13	25
FZA 12 x 60 M 8 D/10	060653	060665	■	–	12 x 60	FZE 12 plus	79	10	M 8	13	25
FZA 12 x 80 M 8 D/30	060654	060666	■	–	12 x 80	FZE 12 plus	99	30	M 8	13	25
FZA 14 x 80 M10 D/20	060657	060669	■	C1	14 x 80	FZE 14 plus	102	20	M 10	17	10
FZA 14 x 100 M 8 D/30	060658	060670	■	C1	14 x 100	FZE 14 plus	126	40	M 10	17	10
FZA 18 x 100 M12 D/20	060684	060672	■	C1	18 x 100	FZE 18 plus	126	20	M 12	19	10
FZA 18 x 130 M12 D/50	060685	060673	■	C1	18 x 130	FZE 18 plus	156	50	M 12	19	10
FZA 22 x 125 M16 D/25	060663	060675	■	C1	22 x 125	FZE 22 plus	156	25	M 16	24	10

ZYKON hammerset anchor FZEA II

The internally threaded anchor with low anchoring depth for individual fixings in cracked concrete

TECHNICAL DATA



Zykron-Hammerset anchor FZEA II

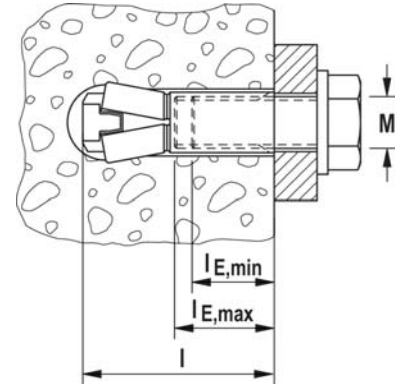

	zinc-plated steel	stainless steel	highly corrosion resistant steel	Approval	Required drill bit FZUB	Required setting tool FZED plus	Length l [mm]	Internal thread A1	Max. bolt penetration l _{E,max} [mm]	Min. bolt penetration l _{E,min} [mm]	Sales unit [pcs]
Item	Art.-No.	Art.-No.	Art.-No.	ETA							
	gvz	A4	C								
FZEA II 10 x 40 M 8	047303	047306	047309	■	10 x 40	FZED 10 plus	43	M 8	17	11	100
FZEA II 12 x 40 M10	047304	047307	047310	■	12 x 40	FZED 12 plus	43	M 10	19	13	100
FZEA II 14 x 40 M12	047305	047308	—	■	14 x 40	FZED 14 plus	43	M 12	21	15	50

Concrete screw ULTRACUT FBS II / FBS

The fully removable fixing for cracked concrete

TECHNICAL DATA



ULTRACUT FBS II US - hexagon head with integral washer

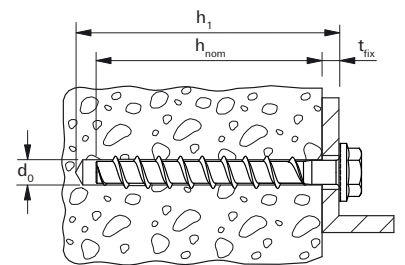

	Art.-No.	Approval	Drill hole diameter d ₀ [mm]	Min. drill hole depth for through fixings h ₁ [mm]	Screw d _a x l _s [mm]	Screw-in depth with fixture thickness h _{nom1} / t _{fix} [mm]	Screw-in depth with fixture thickness h _{nom2} / t _{fix} [mm]	Screw-in depth with fixture thickness h _{nom3} / t _{fix} [mm]	Drive	Sales unit [pcs]
Item	gvz	ETA								
ULTRACUT FBS II 8x55 5/- US TX	536851	■	8	65	10 x 55	50 / 5	- / -	- / -	TX40/SW13	50
ULTRACUT FBS II 8x70 20/5 US TX	536852	■	8	80	10 x 70	50 / 20	- / -	65 / 5	TX40/SW13	50
ULTRACUT FBS II 8x80 30/15 US TX	536853	■	8	90	10 x 80	50 / 30	- / -	65 / 15	TX40/SW13	50
ULTRACUT FBS II 8x90 40/25 US TX	536854	■	8	100	10 x 90	50 / 40	- / -	65 / 25	TX40/SW13	50
ULTRACUT FBS II 8x100 50/35 US TX	536855	■	8	110	10 x 100	50 / 50	- / -	65 / 35	TX40/SW13	50
ULTRACUT FBS II 8x110 60/45 US TX	536856	■	8	120	10 x 110	50 / 60	- / -	65 / 45	TX40/SW13	50
ULTRACUT FBS II 8x130 80/65 US TX	536857	■	8	140	10 x 130	50 / 80	- / -	65 / 65	TX40/SW13	50
ULTRACUT FBS II 10x60 5/-/- US	536858	■	10	70	12 x 60	55 / 5	- / -	- / -	SW 15	50
ULTRACUT FBS II 10x70 15/5/- US	536859	■	10	80	12 x 70	55 / 15	65 / 5	- / -	SW 15	50
ULTRACUT FBS II 10x80 25/15/- US	536860	■	10	90	12 x 80	55 / 25	65 / 15	- / -	SW 15	50
ULTRACUT FBS II 10x90 35/25/5 US	536861	■	10	100	12 x 90	55 / 35	65 / 25	85 / 5	SW 15	50
ULTRACUT FBS II 10x100 45/35/15 US	536862	■	10	110	12 x 100	55 / 45	65 / 35	85 / 15	SW 15	50

TECHNICAL DATA

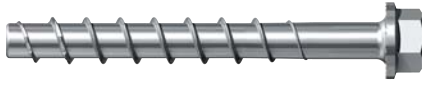

ULTRACUT FBS II US - hexagon head with integral washer

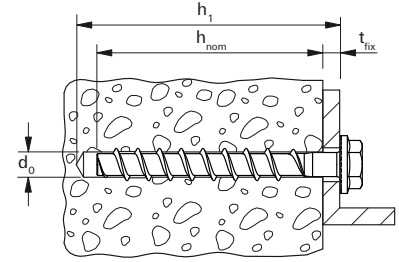

Item	Art.-No.	Approval ETA	Drill hole diameter	Min. drill hole depth for through fixings	Screw	Screw-in depth with fixture thickness	Screw-in depth with fixture thickness	Screw-in depth with fixture thickness	Drive	Sales unit [pcs]
			d_0 [mm]	h_1 [mm]	$d_a \times l_s$ [mm]	h_{nom1} / t_{fix} [mm]	h_{nom2} / t_{fix} [mm]	h_{nom3} / t_{fix} [mm]		
ULTRACUT FBS II 10x120 65/55/35 US	536863	■	10	130	12 x 120	55 / 65	65 / 55	85 / 35	SW 15	50
ULTRACUT FBS II 10x140 85/75/55 US	536864	■	10	150	12 x 140	55 / 85	65 / 75	85 / 55	SW 15	50
ULTRACUT FBS II 10x160 105/95/75 US	536865	■	10	170	12 x 160	55 / 105	65 / 95	85 / 75	SW 15	50
ULTRACUT FBS II 10x200 145/135/115 US	536866	■	10	210	12 x 200	55 / 145	65 / 135	85 / 115	SW 15	20
ULTRACUT FBS II 10x230 175/165/145 US	536867	■	10	240	12 x 230	55 / 175	65 / 165	85 / 145	SW 15	20
ULTRACUT FBS II 10x260 205/195/175 US	536868	■	10	270	12 x 260	55 / 205	65 / 195	85 / 175	SW 15	20
ULTRACUT FBS II 12x70 10/-/- US	536869	■	12	80	14 x 70	60 / 10	- / -	- / -	SW 17	20
ULTRACUT FBS II 12x85 25/10/- US	536870	■	12	95	14 x 85	60 / 25	75 / 10	- / -	SW 17	20
ULTRACUT FBS II 12x110 50/35/10 US	536871	■	12	120	14 x 110	60 / 50	75 / 35	100 / 10	SW 17	20
ULTRACUT FBS II 12x130 70/55/30 US	536872	■	12	140	14 x 130	60 / 70	75 / 55	100 / 30	SW 17	20
ULTRACUT FBS II 12x150 90/75/50 US	536873	■	12	160	14 x 150	60 / 90	75 / 75	100 / 50	SW 17	20
ULTRACUT FBS II 14x75 10/-/- US	536874	■	14	90	16 x 75	65 / 10	- / -	- / -	SW 21	20
ULTRACUT FBS II 14x95 30/10/- US	536875	■	14	110	16 x 95	65 / 30	85 / 10	- / -	SW 21	20
ULTRACUT FBS II 14x100 35/15/- US	536876	■	14	115	16 x 100	65 / 35	85 / 15	- / -	SW 21	20
ULTRACUT FBS II 14x125 60/40/10 US	536877	■	14	140	16 x 125	65 / 60	85 / 40	115 / 10	SW 21	10
ULTRACUT FBS II 14x150 85/65/35 US	536878	■	14	165	16 x 150	65 / 85	85 / 65	115 / 35	SW 21	10

14

TECHNICAL DATA

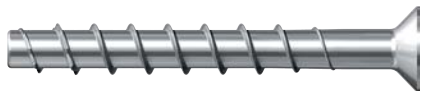

ULTRACUT FBS II SK - countersunk head

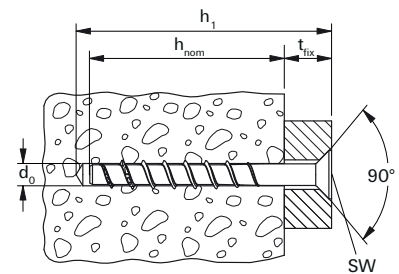

Item	Art.-No.	Approval ETA	Drill hole diameter	Min. drill hole depth for through fixings	Screw	Screw-in depth with fixture thickness	Screw-in depth with fixture thickness	Screw-in depth with fixture thickness	Drive	Sales unit [pcs]
			d_0 [mm]	h_1 [mm]	$d_a \times l_s$ [mm]	h_{nom1} / t_{fix} [mm]	h_{nom2} / t_{fix} [mm]	h_{nom3} / t_{fix} [mm]		
ULTRACUT FBS II 8x60 10/- SK	536880	■	8	70	10 x 60	50 / 10	- / -	- / -	TX40	50
ULTRACUT FBS II 8x80 30/15 SK	536881	■	8	90	10 x 80	50 / 30	- / -	65 / 15	TX40	50
ULTRACUT FBS II 8x90 40/25 SK	536882	■	8	100	10 x 90	50 / 40	- / -	65 / 25	TX40	50
ULTRACUT FBS II 10x65 10/-/- SK	536884	■	10	75	12 x 65	55 / 10	- / -	- / -	TX50	50
ULTRACUT FBS II 10x80 25/15/- SK	536885	■	10	90	12 x 80	55 / 25	65 / 15	- / -	TX50	50
ULTRACUT FBS II 10x95 40/30/10 SK	536886	■	10	105	12 x 95	55 / 40	65 / 30	85 / 10	TX50	50
ULTRACUT FBS II 10x100 45/35/15 SK	536887	■	10	110	12 x 100	55 / 45	65 / 35	85 / 15	TX50	50
ULTRACUT FBS II 10x120 65/55/35 SK	536888	■	10	130	12 x 120	55 / 65	65 / 55	85 / 35	TX50	50

Plugs and anchors

ACCESSORIES



Filling washer **FFD**



Washer **U**

Item	Art.-No.	Internal diameter	External-Ø	Match	Sales unit
		[mm]	d [mm]		
FFD 26 x 12 x 6	538458	12,0	26	FBS II 8	4
FFD 30 x 14 x 6	538459	14,2	30	FBS II 10 / FBS II 12	4
FFD 38 x 19 x 7	538460	19,2	38	FBS II 14	4
Washer for FBS 10	520471	13,5	44	FBS II 10	50

TECHNICAL DATA



Concrete screw **FBS-US A4** with hexagon head and molded washer, stainless steel A4



Concrete screw **FBS-US A4** - with hexagon head and molded washer, stainless steel A4

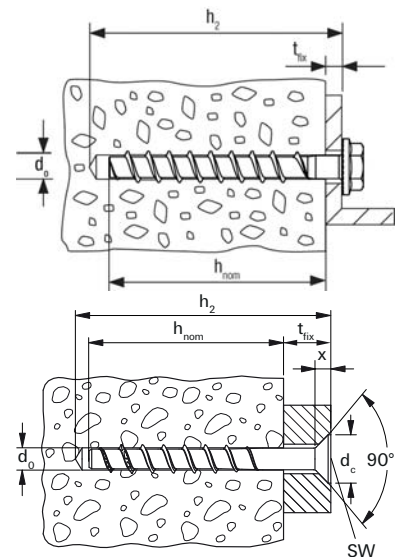

	X [mm]	dc [mm]
FBS II 8	7	23
FBS II 10	7	25

Item	stainless steel	Approval	Drill hole diameter	Min. drill hole depth for through fixings	Screw length	Screw-in depth	Max. fixture thickness	Drive	Sales unit
	Art.-No.		ETA	d ₀ [mm]	h ₂ [mm]	l _s [mm]	h _{nom} [mm]		
	A4								
FBS 8 x 70/5 US A4	523899	■	8	80	70	65	5	SW 13	25
FBS 8 x 80/15 US A4	523900	■	8	90	80	65	15	SW 13	25
FBS 8 x 90/25 US A4	523901	■	8	100	90	65	25	SW 13	25
FBS 10 x 90/5 US A4	523902	■	10	100	90	85	5	SW 15	25
FBS 10 x 100/15 US A4	523903	■	10	110	100	85	15	SW 15	25
FBS 10 x 120/35 US A4	523904	■	10	130	120	85	35	SW 15	25
FBS 12 x 110/10 US A4	523905	■	12	120	110	100	10	SW 17	20
FBS 12 x 130/30 US A4	523906	■	12	140	130	100	30	SW 17	20
FBS 8 x 80/15 SK A4	534063	■	8	90	80	65	15	T40	20
FBS 8 x 90/25 SK A4	534064	■	8	100	90	65	25	T40	20
FBS 10 x 90/5 SK A4	534065	■	10	100	90	85	5	T50	20
FBS 10 x 110/25 SK A4	534067	■	10	120	110	85	25	T50	20

TECHNICAL DATA



Concrete screw **FBS-P**, panhead



Concrete screw **FBS-SK**, countersunk head



Concrete screw **FBS-US** - hexagon head with integral washer

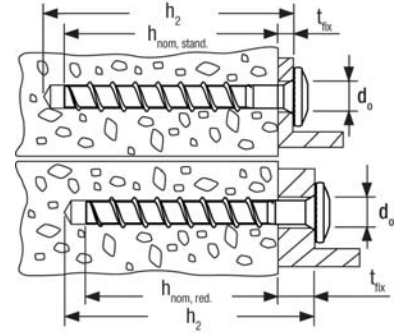

Item	Art.-No.	Approval ETA	Drill hole diameter	Min. drill hole depth for through fixings	Screw length	Head-Ø	Screw-in depth	Usable length	Drive	Sales unit [pcs]
			d_0 [mm]	h_2 [mm]	l_s [mm]	d_K [mm]	$h_{nom, stand.} / h_{nom, red.}$ [mm]	$t_{fix, stand.} / t_{fix, red.}$ [mm]		
FBS 5 x 60/5 P	066774	■	5	65	60	15	55 / -	5 / -	T30	100
FBS 6 x 40/5 P	523910	■	6	50	40	15	- / 35	- / 5	T30	100
FBS 6 x 40/5 LP	523911	■	6	50	40	18	- / 35	- / 5	T30	100
FBS 6 x 60/5 P	066939	■	6	70	60	15	55 / 35	5 / 25	T30	100
FBS 6 x 80/25 P	066948	■	6	90	80	15	55 / 35	25 / 45	T30	100
FBS 6 x 40/5 SK	523914	■	6	50	40	13.0	- / 35	- / 5	T30	100
FBS 6 x 60/5 SK	066935	■	6	70	60	13.0	55 / 35	5 / 25	T30	100
FBS 6 x 80/25 SK	523915	■	6	90	80	13.0	55 / 35	25 / 45	T50	100
FBS 6 x 100/45 SK	523916	■	6	110	100	13.0	55 / 35	45 / 65	T30	100
FBS 6 x 40/5 US	523907	■	6	50	40	17	- / 35	- / 5	T30/SW13	100
FBS 6 x 60/5 US	523908	■	6	70	60	17	55 / 35	5 / 25	T30/SW13	100
FBS 6 x 80/25 US	523909	■	6	90	80	17	55 / 35	25 / 45	T30/SW13	100

TECHNICAL DATA



Concrete screw **FBS-M8**, outside diameter M8



Concrete screw **FBS-M8/M10 I**, internal thread M8/M10

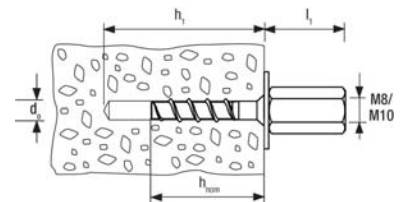

Item	zinc-plated steel	Art.-No.	Approval ETA	Drill hole diameter	Min. drill hole depth for pre-positioned installation	Projection length	Screw-in depth	Drive	Sales unit [pcs]
				d_0 [mm]	h_1 [mm]	l_1 [mm]	$h_{nom, stand.} / h_{nom, red.}$ [mm]		
FBS 6 x 35 M8/M10 I		523912 1)	■	6	45	26.5	- / 35	SW 13	100
FBS 6 x 55 M8/M10 I		066950 1)	■	6	65	26.5	55 / -	SW 13	100
FBS 6 x 35 M8/19		523913 1)	■	6	45	19	- / 35	SW 10	100
FBS 6 x 55 M8/15		066949 1)	■	6	65	19	55 / -	SW 10	100

1) Further lengths and highly corrosion resistant material 1.4529 on request.

Hammerset anchor EA II

The internally threaded anchor with rim for simple hammerset installation

TECHNICAL DATA



Hammerset anchor **EA II**, with reduced anchorage depth h_{ef} 25 mm.



Hammerset anchor **EA II**. **Not suitable for diamond drilling appliances and diamond saws.**

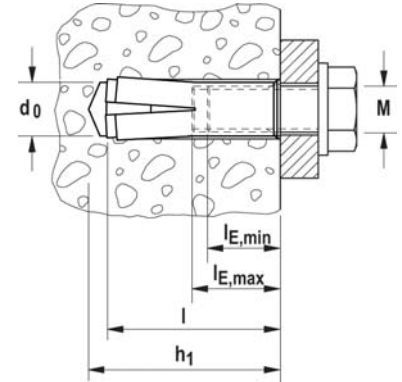

	zinc-plated steel	stainless steel	Approval	Drill hole diameter	Min. drill hole depth for pre-positioned installation	Anchor length	Internal thread	Min. bolt penetration	Max. bolt penetration	Sales unit
	Art.-No.	Art.-No.	ETA	d_0 [mm]	h_1 [mm]	l [mm]	A1	$l_{E,min}$ [mm]	$l_{E,max}$ [mm]	[pcs]
Item	gvz	A4								
EA II M 6 x 25	532230	—	■	8	27	25	M 6	6	14	100
EA II M 6 x 30	048264	048410	■	8	32	30	M 6	6	14	100
EA II M 8 x 25	532231	—	■	10	27	25	M 8	8	14	100
EA II M 8 x 30	048284	048411	■	10	33	30	M 8	8	14	100
EA II M 8 x 40	048323	048412	■	10	43	40	M 8	8	14	50
EA II M 10 x 25	532232	—	■	12	27	25	M 10	10	14	50
EA II M 10 x 30	048332	—	■	12	33	30	M 10	10	14	50
EA II M 10 x 40	048339	048414	■	12	43	40	M 10	10	17	50
EA II M 12 x 25	532233	—	■	15	27	25	M 12	12	14	25
EA II M 12 x 50	048406	048415	■	15	54	50	M 12	12	22	25
EA II M 16 x 65	048408	048416	■	20	70	65	M 16	16	28	20
EA II M 20 x 80	048409	048417	■	25	85	80	M 20	20	34	10

Associated setting tool for manual installation (EHS Plus), for installation with hammer drill (EMS)

ACCESSORIES



Machine setting tool **EMS**

Item	Art.-No.	Tool holder	Match	Sales unit [pcs]
EMS M 6 x 25/30	048065	SDS plus	EA II M 6 x 25, EA II M 6 x 30	1
EMS M 8 x 25/30	048066	SDS plus	EA II M 8 x 25, EA II M 8 x 30	1
EMS M 8 x 40	048067	SDS plus	EA II M 8 x 40	1
EMS M 10 x 25/30	048068 ¹⁾	SDS plus	EA II M 10 x 25, EA II M 10 x 30	1
EMS M 10 x 40	048070	SDS plus	EA II M 10 x 40	1
EMS M 12 x 25	532569	SDS plus	EA II M 12 x 25	1
EMS M 12 x 50	048071	SDS plus	EA II M 12 x 50 D / EA II M 12 x 50 / EA M 12 x 50 N D	1
EMS M 16 x 65	048072 ¹⁾	SDS max	EA II M 16 x 65	1
EMS M 20 x 80	048073 ¹⁾	SDS max	EA II M 20 x 80	1

¹⁾ Delivery time on request.

ACCESSORIES



Setting tool **EHS Plus** with hand impact protection for your safety and embossing tool.



Setting tool **EA-ST**

Item		Match	Sales unit [pcs]
EHS M 6 x 25/30 Plus	044630	EA II M 6 x 25, EA II M 6 x 30	1
EHS M 8 x 25/30 Plus	044631	EA II M 8 x 25, EA II M 8 x 30	1
EHS M 8 x 40 Plus	044632	EA II M 8 x 40	1
EHS M 10 x 25/30 Plus	048487	EA II M 10 x 25, EA II M 10 x 30	1
EHS M 10 x 40 Plus	044633	EA II M 10 x 40	1
EHS M 12 x 25 Plus	532568	EA II M 12 x 25	1
EHS M 12 x 50 Plus	044634	EA II M 12 x 50, EA II M 12 x 50 D	1
EHS M 16 x 65 Plus	044635	EA II M 16 x 65	1
EHS M 20 x 80 Plus	044636	EA II M 20 x 80	1
EA-ST 12	504585	EA M 12 x 50 N D	1

Nail anchor FNA II

The installation-friendly hammer-set anchor for multiple fixings

TECHNICAL DATA



Nail anchor **FNA II** with nail head

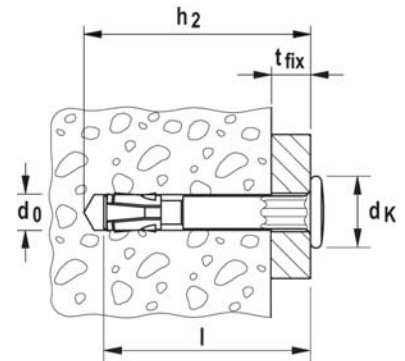

Item	zinc-plated steel	stainless steel	highly corrosion resistant steel	Approval ETA	Drill hole diameter	Min. drill hole depth for through fixings	Anchor length	Max. fixture thickness	Head-Ø	Sales unit	
	Art.-No.	Art.-No.	Art.-No.		d_0 [mm]	h_2 [mm]	l [mm]	t_{fix} [mm]	d_k [mm]	[pcs]	
	gvz	A4	C								
FNA II 6 x 25/5	044121 ¹⁾	—	—	■	6	40	35	5	13.0	100	
FNA II 6 x 30/5	044115 ¹⁾	044122	—	■	6	45	40	5	13.0	100	
FNA II 6 x 30/5	—	—	044124	■	6	45	40	5	13.0	25	
FNA II 6 x 30/30	044116	044123	—	■	6	70	65	30	13.0	50	
FNA II 6 x 30/30	—	—	044125	■	6	70	65	30	13.0	25	
FNA II 6 x 30/50	044117	046024	500569	■	6	90	85	50	13.0	50	
FNA II 6 x 30/75	044118	—	500573 ²⁾	■	6	115	110	75	13.0	50	
FNA II 6 x 30/100	044119	—	500574 ³⁾	■	6	140	135	100	13.0	50	
FNA II 6 x 30/120	044120	—	500575 ³⁾	■	6	160	155	120	13.0	50	

¹⁾ with hexagon below the nail head for anti-rotation lock of hole and wire hangers (for example) and centring for optional setting tool FNA-S

²⁾ On request.

³⁾ Delivery time on request.

TECHNICAL DATA

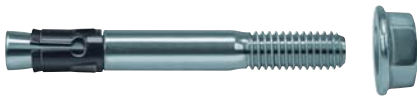

Nail anchor **FNA II M6**
with thread and flange nut

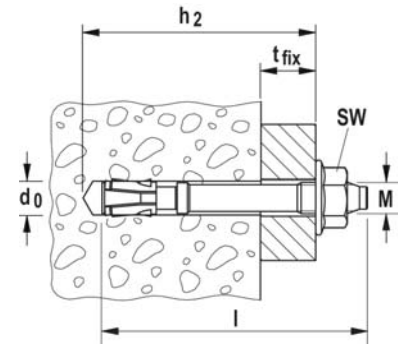

	zinc-plated steel	highly corrosion resistant steel	stainless steel	Approval	Drill hole diameter	Min. drill hole depth for through fixings	Anchor length	Max. fixture thickness	Thread	Width across nut	Sales unit
	Art.-No.	Art.-No.	Art.-No.	ETA	d_0 [mm]	h_2 [mm]	l [mm]	t_{fix} [mm]	M	\circ SW [mm]	[pcs]
Item	gvz	A4	C								
FNA II 6 x 25 M6/5	044111	—	—	■	6	40	45	5	M 6	10	100
FNA II 6 x 30 M6/5	044109	—	—	■	6	45	50	5	M 6	10	100
FNA II 6 x 30 M6/5	—	—	044112 2)	■	6	45	50	5	M 6	10	50
FNA II 6 x 30 M6/5	—	044113 2)	—	■	6	45	50	5	M 6	10	25
FNA II 6 x 30 M6 x 41	044110 1)	—	—	■	6	40	41	—	M 6	10	100
FNA II 6 x 30 M6/10	046022	—	—	■	6	45	55	10	M 6	10	100
FNA II 6 x 30 M8/5	044114	—	—	■	6	45	51	5	M 8	13	50

1) without nut; e.g. for fixing of pipe clamps

2) with nut and washer (no flange nut)

Ceiling nail FDN

The cost-efficient push-through anchor for multiple fixings

TECHNICAL DATA

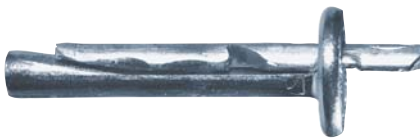

Ceiling nail **FDN**

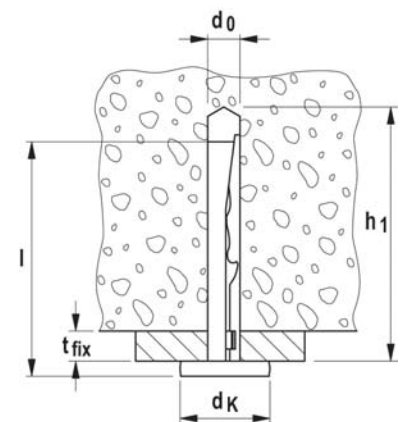

	zinc-plated steel	Approval	Drill hole diameter	Anchor length	Max. fixture thickness	Min. drill hole depth	Head-Ø	Sales unit
	Art.-No.	ETA	d_0 [mm]	l [mm]	t_{fix} [mm]	h_1 [mm]	d_k [mm]	[pcs]
Item	gvz							
FDN 6/5 (6 x 35)	078644	■	6	43	5	45	15	100
FDN 6/35 (6 x 65)	078645	■	6	73	35	75	15	100

Aircrete anchor FPX-I

The strong internally threaded anchor with unique 4-way expansion for fixings in aerated concrete

TECHNICAL DATA



Aircrete anchor **FPX-I**

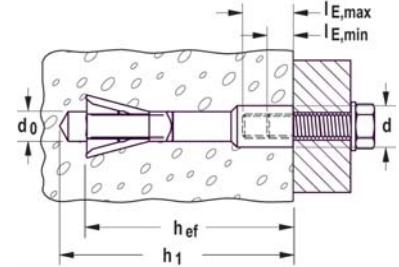

	Art.-No.	Approval ETA	Drill diameter d_0 [mm]	Min. drill hole depth for pre-positioned installation h_1 [mm]	Anchor length l [mm]	Effect. anchorage depth h_{ef} [mm]	Min. bolt pene- tration $l_{E,min}$ [mm]	Max. bolt pene- tration $l_{E,max}$ [mm]	Sales unit [pcs]
Item	gvz								
FPX M6-I	519021	■	10	95	75	70	10	15	25
FPX M8-I	519022	■	10	95	75	70	8	15	25
FPX M10-I	519023	■	10	95	75	70	10	15	25
FPX M12-I	519024	■	10	95	75	70	12	15	25

ACCESSORIES



Setting tool **FPX M6 I**



Setting tool **FPX M8-M12 I**

Item	Art.-No.	Matching anchor type	Sales unit [pcs]
Setting tool FPX M6 I	522517	FPX M6-I	10
Setting tool FPX M8-M12 I	522518	FPX M8-I - FPX M12-I	10

Injection mortar FIS HB The best performance in cracked concrete

TECHNICAL DATA



Injection mortar **FIS HB 345 S**
+ FIS MR



Injection mortar **FIS HB 150 C**

		Approval	Languages on the cartridge	Scale unit	Contents	Sales unit
Item	Art.-No.	ETA				[pcs]
FIS HB 345 S	033211	■	D, GB, F, E, NL, CZ	180	1 cartridge 360 ml, 2 x FIS MR	6
FIS HB 150 C	519665	■	D, F, NL	70	1 cartridge 145 ml, 2 x FIS MR	6
FIS MR	096448	—	—	—	10 static mixer	10

Highbond-Resin Capsule FHB II-P / FHB II-PF The best performance in cracked concrete

TECHNICAL DATA



Resin capsule **FHB II-P** (standard)

Item	Art.-No.	Approval	Drill hole diameter d_0 [mm]	Drill hole depth h_0 [mm]	Anchorage depth h_{ef} [mm]	Match	Sales unit [pcs]
FHB II-P 8 x 60	096824	■	10	75	60	FHB II-A L M 8 x 60	10
FHB II-P 10 x 60	096847	■	10	75	60	FHB II-S M 10 x 60	10
FHB II-P 10 x 75	508016	■	10	90	75	FHB II-A S M 10 x 75	10
FHB II-P 10 x 95	096843	■	12	110	95	FHB II-A L M 10 x 95	10
FHB II-P 12 x 75	096848	■	12	90	75	FHB II-A S M 12 x 75	10
FHB II-P 12 x 100	507922	■	14	115	100	FHB II-A L M 12 x 100	10
FHB II-P 12 x 120	096844	■	14	135	120	FHB II-A L M 12 x 120	10
FHB II-P 16 x 95	096849	■	16	110	95	FHB II-A S M 16 x 95	10
FHB II-P 16 x 125	507923	■	18	145	125	FHB II-A L M 16 x 125	10
FHB II-P 16 x 145	507924	■	18	165	145	FHB II-A L M 16 x 145	10
FHB II-P 16 x 160	096845	■	18	175	160	FHB II-A L M 16 x 160	10
FHB II-P 20 x 170	507925	■	25	190	170	FHB II-A S M 20 x 170	4
FHB II-P 20 x 210	096846	■	25	235	210	FHB II-A L M 20 x 210	4
FHB II-P 24 x 170	096851	■	25	190	170	FHB II-A S M 24 x 170	4
FHB II-P 24 x 210	507926	■	25	235	210	FHB II-A L M 24 x 210	4

TECHNICAL DATA



Resin capsule **FHB II-PF HIGH SPEED**
(quick version)

Item	Art.-No.	Approval	Drill hole diameter d_0 [mm]	Drill hole depth h_0 [mm]	Anchorage depth h_{ef} [mm]	Match	Sales unit [pcs]
FHB II-PF 8 x 60	500542	■	10	75	60	FHB II-A L M 8 x 60	10
FHB II-PF 10 x 60	500547	■	10	75	60	FHB II-S M 10 x 60	10
FHB II-PF 10 x 75	507999	■	10	90	75	FHB II-A S M 10 x 75	10
FHB II-PF 10 x 95	500543	■	12	110	95	FHB II-A L M 10 x 95	10
FHB II-PF 12 x 75	500548	■	12	90	75	FHB II-A S M 12 x 75	10
FHB II-PF 12 x 100	508000	■	14	115	100	FHB II-A L M 12 x 100	10
FHB II-PF 12 x 120	500544	■	14	135	120	FHB II-A L M 12 x 120	10

TECHNICAL DATA



Resin capsule **FHB II-PF HIGH SPEED**
(quick version)

Item	Art.-No.	Approval ETA	Drill hole diameter d_0 [mm]	Drill hole depth h_0 [mm]	Anchorage depth h_{ef} [mm]	Match	Sales unit [pcs]
FHB II-PF 16 x 95	500549	■	16	110	95	FHB II-A S M 16 x 95	10
FHB II-PF 16 x 125	508001	■	18	145	125	FHB II-A L M 16 x 125	10
FHB II-PF 16 x 145	508002	■	18	165	145	FHB II-A L M 16 x 145	10
FHB II-PF 16 x 160	500545	■	18	175	160	FHB II-A L M 16 x 160	10
FHB II-PF 20 x 170	508003	■	25	190	170	FHB II-A S M 20 x 170	4
FHB II-PF 20 x 210	500546	■	25	235	210	FHB II-A L M 20 x 210	4
FHB II-PF 24 x 170	500550	■	25	190	170	FHB II-A S M 24 x 170	4
FHB II-PF 24 x 210	508004	■	25	235	210	FHB II-A L M 24 x 210	4

Highbond anchor FHB II-A S / FHB II A-L

The best performance in cracked concrete with the least installation effort

TECHNICAL DATA



Highbond anchor **FHB II-A S** (short version)

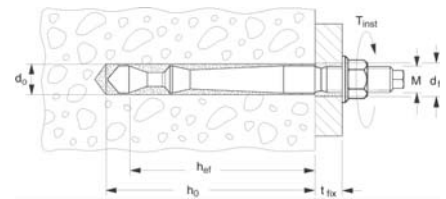

Item	zinc-plated steel	stainless steel	highly cor- rosion resistant steel	Approval ETA	Drill hole diameter d_0 [mm]	Drill hole depth h_0 [mm]	Anchorage depth h_{ef} [mm]	Usable length t_{fix} [mm]	Thread M	Width across nut ○ SW [mm]	Sales unit [pcs]
	Art.-No.	Art.-No.	Art.-No.								
	gvz	A4	C								
FHB II-A S M10 x 60/10	097072	097630	097704 1)	■	10	75	60	10	M 10	17	10
FHB II-A S M10 x 60/20	097073	097631	—	■	10	75	60	20	M 10	17	10
FHB II-A S M10 x 60/40	—	097632	—	■	10	75	60	40	M 10	17	10
FHB II-A S M10 x 60/60	097074	097633	—	■	10	75	60	60	M 10	17	10
FHB II-A S M10 x 60/100	097206	097634	—	■	10	75	60	100	M 10	17	10
FHB II-A S M10 x 75/10	506884	506888	—	■	10	90	75	10	M 10	17	10
FHB II-A S M10 x 75/20	506885	506889	—	■	10	90	75	20	M 10	17	10
FHB II-A S M10 x 75/40	—	506890	—	■	10	90	75	40	M 10	17	10
FHB II-A S M10 x 75/60	506886	506891	—	■	10	90	75	60	M 10	17	10
FHB II-A S M10 x 75/100	506887	506892	—	■	10	90	75	100	M 10	17	10
FHB II-A S M12 x 75/10	097257	097635	—	■	12	90	75	10	M 12	19	10
FHB II-A S M12 x 75/25	097268	097636	097706 1)	■	12	90	75	25	M 12	19	10
FHB II-A S M12 x 75/40	—	097637	—	■	12	90	75	40	M 12	19	10
FHB II-A S M12 x 75/60	097274	097638	—	■	12	90	75	60	M 12	19	10
FHB II-A S M12 x 75/100	097275	097639	—	■	12	90	75	100	M 12	19	10
FHB II-A S M12 x 75/165	097280	097640	—	■	12	90	75	165	M 12	19	10
FHB II-A S M16 x 95/30	097281	097641	097708 1)	■	16	110	95	30	M 16	24	10
FHB II-A S M16 x 95/60	097286	097642	—	■	16	110	95	60	M 16	24	10
FHB II-A S M16 x 95/100	097295	097643	—	■	16	110	95	100	M 16	24	10
FHB II-A S M16 x 95/165	097296	097644	—	■	16	110	95	165	M 16	24	10
FHB II-A S M20 x 170/50	506917	506919	—	■	25	190	170	50	M 20	30	4
FHB II-A S M24 x 170/50	097297	097645	—	■	25	190	170	50	M 24	36	4

1) Delivery time on request.

TECHNICAL DATA



Highbond anchor **FHB II-A L** (long version)

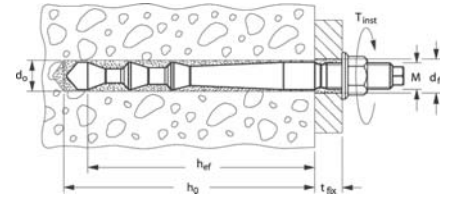

Item	zinc-plated steel	stainless steel	highly corrosion resistant steel	Approval ETA	Drill hole diameter	Drill hole depth	Anchorage depth	Usable length	Thread M	Width across nut	Sales unit [pcs]
	Art.-No.	Art.-No.	Art.-No.		d ₀ [mm]	h ₀ [mm]	h _{ef} [mm]	t _{fix} [mm]		○ SW [mm]	
	gvz	A4	C								
FHB II-A L M8 x 60/10	097032	097298	097696 ¹⁾	■	10	75	60	10	M 8	13	10
FHB II-A L M8 x 60/30	097033	097299	—	■	10	75	60	30	M 8	13	10
FHB II-A L M8 x 60/50	097034	097440	—	■	10	75	60	50	M 8	13	10
FHB II-A L M10 x 95/10	096907	097616	—	■	12	110	95	10	M 10	17	10
FHB II-A L M10 x 95/20	096940	097617	097699 ¹⁾	■	12	110	95	20	M 10	17	10
FHB II-A L M10 x 95/40	—	097618	—	■	12	110	95	40	M 10	17	10
FHB II-A L M10 x 95/60	096941	097619	—	■	12	110	95	60	M 10	17	10
FHB II-A L M10 x 95/100	096942	097620	—	■	12	110	95	100	M 10	17	10
FHB II-A L M12 x 100/10	506893	506897	—	■	14	115	100	10	M 12	19	10
FHB II-A L M12 x 100/25	506894	506898	—	■	14	115	100	25	M 12	19	10
FHB II-A L M12 x 100/40	—	506899	—	■	14	115	100	40	M 12	19	10
FHB II-A L M12 x 100/50 GS A4	—	537065	—	■	14	115	100	50	M 12	19	10
FHB II-A L M12 x 100/60	506895	506901	—	■	14	115	100	60	M 12	19	10
FHB II-A L M12 x 100/100	506896	506902	—	■	14	115	100	100	M 12	19	10
FHB II-A L M12 x 120/10	096943	097621	—	■	14	135	120	10	M 12	19	10
FHB II-A L M12 x 120/25	096944	097622	097700 ¹⁾	■	14	135	120	25	M 12	19	10
FHB II-A L M12 x 120/40	—	097623	—	■	14	135	120	40	M 12	19	10
FHB II-A L M12 x 120/60	097014	097624	—	■	14	135	120	60	M 12	19	10
FHB II-A L M12 x 120/100	097031	097625	—	■	14	135	120	100	M 12	19	10
FHB II-A L M16 x 125/30	506903	506906	—	■	18	140	125	30	M 16	24	10
FHB II-A L M16 x 125/60	506904	506909	—	■	18	140	125	60	M 16	24	10
FHB II-A L M16 x 125/100	506905	506910	—	■	18	140	125	100	M 16	24	10
FHB II-A L M16 x 145/30	506911	506914	—	■	18	160	145	30	M 16	24	10
FHB II-A L M16 x 145/60	506912	506915	—	■	18	160	145	60	M 16	24	10
FHB II-A L M16 x 145/100	506913	506916	—	■	18	160	145	100	M 16	24	10
FHB II-A L M16 x 160/30	097035	097626	097702 ¹⁾	■	18	175	160	30	M 16	24	10
FHB II-A L M16 x 160/60	097038	097627	—	■	18	175	160	60	M 16	24	10
FHB II-A L M16 x 160/100	097070	097628	—	■	18	175	160	100	M 16	24	10
FHB II-A L M20 x 210/50	097071	097629	097703 ¹⁾	■	25	235	210	50	M 20	30	4
FHB II-A L M20 x 210/150	052370	—	—	■	25	235	210	150	M 20	30	8
FHB II-A L M24 x 210/50	506920	506921	—	■	25	235	210	50	M 24	36	4

¹⁾ Delivery time on request.

Superbond mortar FIS SB The concrete-allrounder

TECHNICAL DATA



Superbond mortar
FIS SB 390 S



Static mixer FIS MR

		Approval	Languages on the cartridge	Scale unit	Contents	Sales unit
Item	Art.-No.	ETA				[pcs]
FIS SB 390 S	519451	■	D, F, NL	180	1 cartridge 390 ml, 2 x FIS MR	6
FIS SB 390 S	520557	■	D, SLO, SRB, BG	180	1 cartridge 390 ml, 2 x FIS MR	6
FIS SB 390 S	518831	■	GB, E, P	180	1 cartridge 390 ml, 2 x FIS MR	6
FIS SB 390 S	519450	■	I, GB, D	180	1 cartridge 390 ml, 2 x FIS MR	6
FIS SB 390 S	520559	■	DK, SE, NO, FIN	180	1 cartridge 390 ml, 2 x FIS MR	6
FIS SB 390 S	520555	■	CZ, SK, RO	180	1 cartridge 390 ml, 2 x FIS MR	6
FIS SB 390 S	520595	■	PL, RUS, H	180	1 cartridge 390 ml, 2 x FIS MR	6
FIS SB 585 S	519452	■	GB, E, P	270	1 cartridge 585 ml + 2 x FIS UMR	6
FIS SB 585 S	520526	■	I, GB, D	270	1 cartridge 585 ml + 2 x FIS UMR	6
FIS SB 1500 S	519453	■	D, GB, F, NL, E, P	700	1 cartridge 1500 ml, 2 x FIS UMR	4
FIS SB 1500 S	520528	■	I, PL, RUS, CZ, SK, GB	700	1 cartridge 1500 ml, 2 x FIS UMR	4
FIS SB HIGH SPEED 390 S	523303	■	PL, RUS, HU	180	1 cartridge 390 ml, 2 x FIS MR	6
FIS MR	096448	–	–	–	10 static mixer	10
FIS UMR	520593	–	–	–	10 static mixer FIS UMR for 585 ml and 1500 ml cartridges	10

TECHNICAL DATA



Threaded rod FIS A

Item	zinc plated, steel grade 5.8	zinc plated, steel grade 8.8	stainless steel	Approval		Drill hole diameter d ₀ [mm]	Min. / max. anchorage depth [mm]	Min. / max. usable length [mm]	min. / max. filling quantity FIS SB [scale units]	Sales unit [pcs]
	Art.-No.	Art.-No.	Art.-No.	ETA	ICC					
	g vz	g vz	A4							
FIS A M 8 x 90	090274	519390	090440	■	▲	10	60 / 78	1 / 19	2 / 3	10
FIS A M 8 x 110	090275	519391	090441	■	▲	10	60 / 98	1 / 39	2 / 3	10
FIS A M 8 x 130	090276	519392	090442	■	▲	10	60 / 118	1 / 59	2 / 4	10
FIS A M 8 x 175	090277	519393	090443	■	▲	10	60 / 160	4 / 104	2 / 5	10
FIS A M 8 x 1000	509214	–	509230	■	▲	10	60 / 160	–	2 / 5	10
FIS A M 10 x 110	090278	–	090444	■	▲	12	60 / 96	1 / 37	3 / 4	10
FIS A M 10 x 130	090279	–	090447	■	▲	12	60 / 116	1 / 57	3 / 5	10
FIS A M 10 x 130	–	524170	–	■	▲	12	60 / 116	1 / 57	3 / 5	10
FIS A M 10 x 150	090281	517935	090448	■	▲	12	60 / 136	1 / 77	3 / 5	10
FIS A M 10 x 170	044969	519395	044973	■	▲	12	60 / 156	1 / 97	3 / 6	10
FIS A M 10 x 190	–	517936	–	■	▲	12	60 / 176	1 / 117	3 / 7	10
FIS A M 10 x 200	090282	519396	090449	■	▲	12	60 / 186	1 / 127	3 / 7	10
FIS A M 10 x 1000	509215	509223	509231	■	▲	12	60 / 200	–	3 / 7	10
FIS A M 12 x 120	044971	519397	044974	■	▲	14	70 / 103	1 / 34	3 / 5	10
FIS A M 12 x 140	090283	519398	090450	■	▲	14	70 / 123	1 / 54	3 / 6	10
FIS A M 12 x 160	090284	517937	090451	■	▲	14	70 / 143	1 / 74	3 / 7	10
FIS A M 12 x 180	090285	519399	090452	■	▲	14	70 / 163	1 / 94	3 / 7	10
FIS A M 12 x 200	–	517938	519421	■	▲	14	70 / 183	1 / 114	3 / 8	10
FIS A M 12 x 210	090286	–	090453	■	▲	14	70 / 193	1 / 124	3 / 9	10
FIS A M 12 x 260	090287	–	090454	■	▲	14	70 / 240	4 / 174	3 / 10	10
FIS A M 12 x 1000	509216	509224	509232	■	▲	14	70 / 240	–	3 / 10	10
FIS A M 16 x 130	044972	519400	044975	■	▲	18	80 / 109	1 / 30	5 / 7	10

TECHNICAL DATA



Threaded rod **FIS A**

Item	zinc plated, steel grade 5.8	zinc plated, steel grade 8.8	stainless steel	Approval		Drill hole diameter d ₀ [mm]	Min. / max. anchorage depth [mm]	Min. / max. usable length [mm]	min. / max. filling quantity FIS SB [scale units]	Sales unit [pcs]
	Art.-No.	Art.-No.	Art.-No.	ETA	ICC					
	gvz	gvz	A4							
FIS A M 16 x 175	090288	519401	090455	■	▲	18	80 / 154	1 / 75	5 / 10	10
FIS A M 16 x 200	090289	517939	090456	■	▲	18	80 / 179	1 / 100	5 / 11	10
FIS A M 16 x 250	090290	517940	090457	■	▲	18	80 / 229	1 / 150	5 / 14	10
FIS A M 16 x 300	090291	519402	090458	■	▲	18	80 / 279	1 / 200	5 / 17	10
FIS A M 16 x 1000	509217	509225	509233	■	▲	18	80 / 320	–	5 / 19	10
FIS A M 20 x 245	090292	519404	090459	■	▲	24	90 / 220	1 / 131	11 / 28	10
FIS A M 20 x 290	090293	519406	090460	■	▲	24	90 / 265	1 / 176	11 / 32	10
FIS A M 20 x 1000	–	519410	519427	■	▲	24	90 / 400	–	11 / 48	10
FIS A M 24 x 290	090294	–	090461	■	▲	28	96 / 260	1 / 165	15 / 39	5
FIS A M 24 x 380	090295	–	090462	■	▲	28	96 / 350	1 / 255	15 / 52	5
FIS A M 24 x 1000	533881	–	–	■	▲	28	96 / 480	–	15 / 69	10
FIS A M 30 x 430	090297	–	090464	■	▲	35	120 / 394	1 / 275	27 / 88	5

Injection mortar FIS V

The versatile injection mortar for anchorings in cracked concrete and masonry

TECHNICAL DATA



Injection mortar **FIS V**



Injection mortar **FIS V 410 C**



Static mixer **FIS MR**

Item	Art.-No.	Approval			Languages on the cartridge	Scale unit	Contents	Sales unit [pcs]
		DIBt	ETA	ICC				
FIS V 300 T	531573	●	■	▲	USA, RA, BR, MEX	150	1 cartridge 300 ml, 2 x FIS MR	12
FIS V 360 S	094404	●	■	▲	D, F, NL, TR, H, UAE	180	1 cartridge 360 ml, 2 x FIS MR	6
FIS V 360 S	094405	●	■	▲	GB, I, P, E, PRC, JP	180	1 cartridge 360 ml, 2 x FIS MR	6
FIS V 360 S	068435	●	■	▲	DK, S, N, FIN, PL, GR	180	1 cartridge 360 ml, 2 x FIS MR	6
FIS V 360 S	502283	●	■	▲	LT, LV, EE, UA, RUS, KZ	180	1 cartridge 360 ml, 2 x FIS MR	6
FIS V 360 S	043994	●	■	▲	CZ, SK, PL, H, RO, RUS	180	1 cartridge 360 ml, 2 x FIS MR	6
FIS V 410 C	521431	●	■	▲	I, GB, D	200	1 cartridge 410 ml, 2 x FIS MR	16
FIS V 410 C	534880	●	■	▲	PL, LT, LV, EST, RUS	200	1 cartridge 410 ml, 2 x FIS MR	12
FIS V 410 C	538131	●	■	▲	USA, RA, BR, MEX	200	1 cartridge 410 ml, 2 x FIS MR	12
FIS MR	096448	–	–	–	–	–	10 static mixer	10

TECHNICAL DATA



Threaded rod FIS A

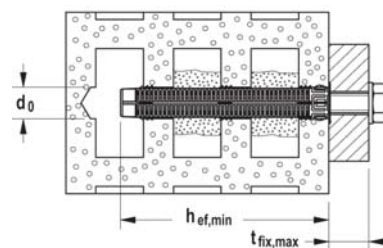

	zinc plated, steel grade 5.8	zinc plated, steel grade 8.8	stainless steel	Approval	Drill hole diameter in perforated brick masonry d_0 [mm]	Min. anchorage depth in perfora- ted brick masonry $h_{ef, min}$ [mm]	Max. useful length in perforated brick masonry $t_{fix, max}$ [mm]	Suitable injection anchor sleeve	Sales unit
Item	Art.-No.	Art.-No.	Art.-No.	ETA					[pcs]
	gvz	gvz	A4						
FIS A M 6 x 70	046204	—	—	■	12	50	11	FIS H 12 x 50 K	10
FIS A M 6 x 75	090243	—	090437	■	12	50	16	FIS H 12 x 50 K	20
FIS A M 6 x 85	090272	—	—	■	12	50	26	FIS H 12 x 50 K	20
FIS A M 6 x 110	090273	—	090439	■	12	50 85	52 17	FIS H 12 x 50 K FIS H 12 x 85 K	20
FIS A M 8 x 90	090274	519390	090440	■	12	50	29	FIS H 12 x 50 K	10
FIS A M 8 x 110	090275	519391	090441	■	12 12 16	50 85 85	49 14 14	FIS H 12 x 50 K FIS H 12 x 85 K FIS H 16 x 85 K	10
FIS A M 8 x 130	090276	519392	090442	■	12/16	50 85 85	69 34 34	FIS H 12 x 50 K FIS H 12 x 85 K FIS H 16 x 85 K	10
FIS A M 8 x 175	090277	519393	090443	■	12 12 16	50 85 85 130	114 79 79 34	FIS H 12 x 50 K FIS H 12 x 85 K FIS H 16 x 85 K FIS H 16 x 130 K	10
FIS A M 10 x 110	090278	—	090444	■	16	85	12	FIS H 16 x 85 K	10
FIS A M 10 x 130	090279	—	090447	■	16	85	32	FIS H 16 x 85 K	10
FIS A M 10 x 130	—	524170	—	■	16	85	32	FIS H 16 x 85 K	10
FIS A M 10 x 150	090281	517935	090448	■	16	85 130	52 7	FIS H 16 x 85 K FIS H 16 x 130 K	10
FIS A M 10 x 170	044969	519395	044973	■	16	85 130	72 27	FIS H 16 x 85 K FIS H 16 x 130 K	10
FIS A M 10 x 190	—	517936	—	■	16	85 130	92 47	FIS H 16 x 85 K FIS H 16 x 130 K	10
FIS A M 10 x 200	090282	519396	090449	■	16	85 130	102 57	FIS H 16 x 85 K FIS H 16 x 130 K	10
FIS A M 12 x 120	044971	519397	044974	■	20	85	19	FIS H 20 x 85 K	10
FIS A M 12 x 140	090283	519398	090450	■	20	85	39	FIS H 20 x 85 K	10
FIS A M 12 x 160	090284	517937	090451	■	20	85 130	59 14	FIS H 20 x 85 K FIS H 20 x 130 K	10
FIS A M 12 x 180	090285	519399	090452	■	20	85 130	79 34	FIS H 20 x 85 K FIS H 20 x 130 K	10
FIS A M 12 x 200	—	517938	—	■	20	85 130	99 54	FIS H 20 x 85 K FIS H 20 x 130 K	10
FIS A M 12 x 210	090286	—	090453	■	20	85 130	109 64	FIS H 20 x 85 K FIS H 20 x 130 K	10
FIS A M 12 x 260	090287	—	090454	■	20	85 130 200	169 114 44	FIS H 20 x 85 K FIS H 20 x 130 K FIS H 20 x 200 K	10
FIS A M 16 x 130	044972	519400	044975	■	20	85	25	FIS H 20 x 85 K	10
FIS A M 16 x 175	090288	519401	090455	■	20	85 130	70 25	FIS H 20 x 85 K FIS H 20 x 130 K	10
FIS A M 16 x 200	090289	517939	090456	■	20	85 130	95 50	FIS H 20 x 85 K FIS H 20 x 130 K	10

TECHNICAL DATA



Threaded rod **FIS A**

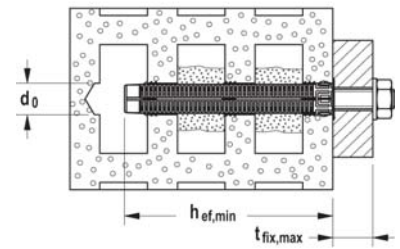

	zinc plated, steel grade 5.8	zinc plated, steel grade 8.8	stainless steel	Approval	Drill hole diameter in perforated brick masonry d_0 [mm]	Min. anchorage depth in perforated brick masonry $h_{ef, min}$ [mm]	Max. useful length in perforated brick masonry $t_{fix, max}$ [mm]	Suitable injection anchor sleeve	Sales unit
	Art.-No.	Art.-No.	Art.-No.	ETA					[pcs]
Item	gvz	gvz	A4						
FIS A M 16 x 250	090290	517940	090457	■	20	85 130 200	145 100 30	FIS H 20 x 85 K FIS H 20 x 130 K FIS H 20 x 200 K	10
FIS A M 16 x 300	090291	519402	090458	■	20	85 130 200	195 150 80	FIS H 20 x 85 K FIS H 20 x 130 K FIS H 20 x 200 K	10

TECHNICAL DATA



Injection anchor sleeve **FIS H K**

	Art.-No.	Approval	Drill hole diameter d_0 [mm]	Drill hole depth acc. ETA [mm]	Effect. anchorage depth h_{ef} [mm]	Match	Fill quantity per sleeve [scale units]	Sales unit [pcs]
Item		ETA						
FIS H 12 x 50 K	041900	■	12	55	50	FIS A M6-M8	5	50
FIS H 12 x 85 K	041901	■	12	90	85	FIS A M6-M8	10	50
FIS H 16 x 85 K	041902	■	16	90	85	FIS A M8-M10, FIS E M6-M8	12	50
FIS H 16 x 130 K	041903	■	16	135	110	FIS A M8-M10	15	20
FIS H 20 x 85 K	041904	■	20	90	85	FIS A M12-M16, FIS E M10-M12	15	20
FIS H 20 x 130 K	046703	■	20	135	110	FIS A M12-M16	25	20
FIS H 20 x 200 K	046704	■	20	205	180	FIS A M12-M16	40	20

TECHNICAL DATA



Internal threaded sockets **FIS E**

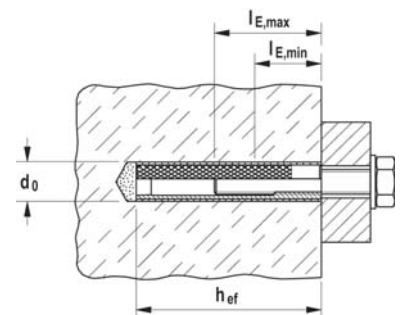

	zinc-plated steel	Approval	Drill hole diameter	Effect. anchorage depth	Min. bolt penetration	Max. bolt penetration	Fill quantity for effect. anchorage depth in solid brick masonry	Sales unit
	Art.-No.	ETA	d_0 [mm]	h_{ef} [mm]	$l_{E, min}$ [mm]	$l_{E, max}$ [mm]	[scale units]	[pcs]
Item	gvz							
FIS E 11 x 85 M6	043631	■	14	85	6	60	4	10
FIS E 11 x 85 M8	043632	■	14	85	8	60	4	10
FIS E 15 x 85 M10	043633	■	18	85	10	60	5	10
FIS E 15 x 85 M12	043634	■	18	85	12	60	5	10

Injection mortar FIS VL

The solid injection mortar for standard applications in cracked concrete and masonry

TECHNICAL DATA



Injection mortar **FIS VL 410 C**



Static mixer **FIS MR**



FIS VL 410 C HWK



FIS VL 410 C in bucket

		Approval	Languages on the cartridge	Scale unit	Contents	Sales unit
Item	Art.-No.	ETA				[pcs]
FIS VL 300 T with clip	537149	■	P, E, GB	150	1 cartridge 300 ml, 2 x FIS MR	12
FIS VL 300 T with clip	538583	■	CZ, SK	150	1 cartridge 300 ml, 2 x FIS MR	10
FIS VL 300 T HIGH SPEED with clip	538585	■	CZ, SK	150	1 cartridge 380 ml, 2 x FIS MR	10
FIS VL 300 T	539461	■	GB, F, E, P, RO, UAE	150	1 cartridge 300 ml, 2 x FIS MR	12
FIS VL 300 T in bucket	539462	■	GB, F, E, P, RO, UAE	150	20 cartridges 300 ml, 40 x FIS MR	1
FIS VL 300 T HWK big	538589	■	CZ, SK	150	20 cartridges 300 ml, 40 x FIS MR	1
FIS VL 410 C	539463	■	GB, F, E, P, RO, UAE	200	1 cartridge 410 ml, 2 x FIS MR	12
FIS VL 410 C	538584	■	CZ, SK	200	1 cartridge 410 ml, 2 x FIS MR	12
FIS VL 410 C HIGH SPEED	538586	■	CZ, SK	200	1 cartridges 410 ml, 1 x FIS MR	12
FIS VL 410 C in bucket	538549	■	D, F, NL, GB, TR	200	16 cartridges 410 ml, 32 x FIS MR	1
FIS VL 410 C in bucket	539464	■	GB, F, E, P, RO, UAE	200	16 cartridges 410 ml, 32 x FIS MR	1
FIS VL 410 C HWK big	538590	■	CZ, SK	200	16 cartridges 410 ml, 32 x FIS MR	1

Frame fixing SXR The all-round solution with short drill hole depth

TECHNICAL DATA



SXR-FUS - with fischer hexagon head safety screw, moulded washer and integrated T40 bit recess

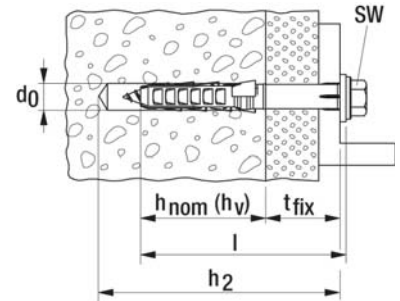

	zinc-plated steel	stainless steel	hot-dip galvanised steel	Approval	Drill hole diameter	Min. drill hole depth for through fixings	Min. anchorage depth	Anchor length	Max. fixture thickness	Drive	Sales unit
	Art.-No.	Art.-No.	Art.-No.	ETA	d_0 [mm]	h_2 [mm]	$h_{nom} (h_v)$ [mm]	l [mm]	t_{fix} [mm]		[pcs]
Item	gvz	A4	fvz								
SXR 10 x 52 FUS	502456 ¹⁾	—	—	■	10	62	50	52	2	T40/SW13	50
SXR 10 x 60 FUS	046329	046339	—	■	10	70	50	60	10	T40/SW13	50
SXR 10 x 60 FUS	—	—	509537	—	10	70	50	60	10	T40/SW13	50
SXR 10 x 80 FUS	046330	046340	—	■	10	90	50	80	30	T40/SW13	50
SXR 10 x 80 FUS	—	—	509538	—	10	90	50	80	30	T40/SW13	50
SXR 10 x 100 FUS	046331	046342	—	■	10	110	50	100	50	T40/SW13	50
SXR 10 x 100 FUS	—	—	509539	—	10	110	50	100	50	T40/SW13	50
SXR 10 x 120 FUS	046332	046343	—	■	10	130	50	120	70	T40/SW13	50
SXR 10 x 140 FUS	046333	046344	—	■	10	150	50	140	90	T40/SW13	50
SXR 10 x 140 FUS	—	—	509540	—	10	150	50	140	90	T40/SW13	50
SXR 10 x 160 FUS	046334	046345	—	■	10	170	50	160	110	T40/SW13	50
SXR 10 x 180 FUS	046335	046361	—	■	10	190	50	180	130	T40/SW13	50
SXR 10 x 200 FUS	046336	046362	—	■	10	210	50	200	150	T40/SW13	50
SXR 10 x 230 FUS	046337	046363	—	■	10	240	50	230	180	T40/SW13	50
SXR 10 x 260 FUS	046338	046364	—	■	10	270	50	260	210	T40/SW13	50

¹⁾ not pre-assembled

Frame fixing SXR-L

The powerful problem solver with long expansion sleeve

TECHNICAL DATA



SXRL-FUS - with fischer hexagon head safety screw, moulded washer and integrated bit recess

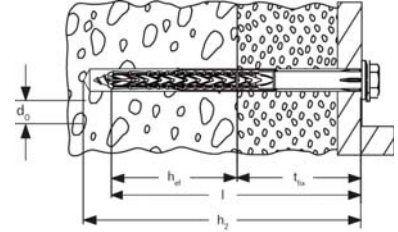

Item	zinc-plated steel	stainless steel	Approval		Drill diameter d_0 [mm]	Min. drill hole depth for through fixings h_2 [mm]	Usable length at anchorage depth 70mm t_{fix} [mm]	Usable length at anchorage depth 90mm t_{fix} [mm]	Anchor length l [mm]	Drive	Sales unit [pcs]
	Art.-No.	Art.-No.	ETA	DIBt							
	gvz	A4									
SXRL 10 x 80 FUS	522719	522730	■	—	10	90	10	—	80	T40/SW13	50
SXRL 10 x 100 FUS	522720	522731	■	—	10	110	30	10	100	T40/SW13	50
SXRL 10 x 120 FUS	522721	522732	■	—	10	130	50	30	120	T40/SW13	50
SXRL 10 x 140 FUS	522723	522733	■	—	10	150	70	50	140	T40/SW13	50
SXRL 10 x 160 FUS	522724	522734	■	—	10	170	90	70	160	T40/SW13	50
SXRL 10 x 180 FUS	522725	522735	■	—	10	190	110	90	180	T40/SW13	50
SXRL 10 x 200 FUS	522726	522736	■	—	10	210	130	110	200	T40/SW13	50
SXRL 10 x 230 FUS	522727	522737	■	—	10	240	160	140	230	T40/SW13	50
SXRL 10 x 260 FUS	522728 1)	522738 1)	■	—	10	270	190	170	260	T40/SW13	50
SXRL 10 x 290 FUS	522729 1)	522739 1)	■	—	10	300	220	200	290	T40/SW13	50
SXRL 14 x 80 FUS	530946	530955	■	●	14	95	10	—	80	T50/SW17	50
SXRL 14 x 100 FUS	530947	530956	■	●	14	115	30	10	100	T50/SW17	50
SXRL 14 x 120 FUS	530948	530957	■	●	14	135	50	30	120	T50/SW17	50
SXRL 14 x 140 FUS	530949	530958	■	●	14	155	70	50	140	T50/SW17	50
SXRL 14 x 160 FUS	530950	530959	■	●	14	175	90	70	160	T50/SW17	50
SXRL 14 x 180 FUS	530951	530960	■	●	14	195	110	90	180	T50/SW17	50
SXRL 14 x 200 FUS	530952	530961	■	●	14	215	130	110	200	T50/SW17	50
SXRL 14 x 230 FUS	530953	530962	■	●	14	245	160	140	230	T50/SW17	50
SXRL 14 x 260 FUS	530954	530963	■	●	14	275	190	170	260	T50/SW17	50

1) not pre-assembled

Stand-off installation Thermax 8 / 10

The thermally separated stand-off installation in external thermal insulation composite systems (ETICS)

TECHNICAL DATA



Thermax 8 and 10

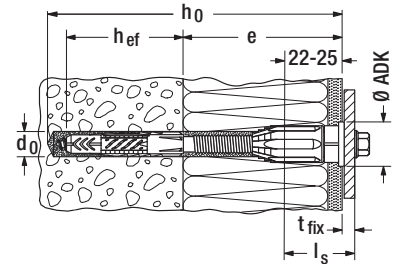

Item	Art.-No.	Drill hole diameter d_0 [mm]	Drill hole depth h_0 [mm]	Usable length e [mm]	Anchorage depth h_{ef} [mm]	Cover cap-Ø ADK [mm]	Width across nut Ø SW [mm]	Chipboard / metric / sheet metal screw	Sales unit [pcs]
Thermax 8/60 M6	045685 1) 2)	10	120	45 - 60	60	18	10	4,5 - 6,0 / M6 / 6,3	20
Thermax 8/80 M6	045686 1) 2)	10	140	60 - 80	60	18	10	4,5 - 6,0 / M6 / 6,3	20
Thermax 8/100 M6	045687 1) 2)	10	160	80 - 100	60	18	10	4,5 - 6,0 / M6 / 6,3	20
Thermax 8/120 M6	045688 1) 2)	10	180	100 - 120	60	18	10	4,5 - 6,0 / M6 / 6,3	20
Thermax 8/140 M6	045689 1) 2)	10	200	120 - 140	60	18	10	4,5 - 6,0 / M6 / 6,3	20
Thermax 8/160 M6	045690 1) 2)	10	220	140 - 160	60	18	10	4,5 - 6,0 / M6 / 6,3	20
Thermax 8/180 M6	045691 1) 2)	10	240	160 - 180	60	18	10	4,5 - 6,0 / M6 / 6,3	20
Thermax 10/100 M6	045692 1) 2)	12	160	80 - 100	70	22	13	4,5 - 6,0 / M6 / 6,3	20
Thermax 10/120 M6	045693 1) 2)	12	180	100 - 120	70	22	13	4,5 - 6,0 / M6 / 6,3	20
Thermax 10/140 M6	045694 1) 2)	12	200	120 - 140	70	22	13	4,5 - 6,0 / M6 / 6,3	20
Thermax 10/160 M6	045695 1) 2)	12	220	140 - 160	70	22	13	4,5 - 6,0 / M6 / 6,3	20
Thermax 10/180 M6	045696 1) 2)	12	240	160 - 180	70	22	13	4,5 - 6,0 / M6 / 6,3	20
Thermax 10/200 M6	512605 1) 2)	12	260	180 - 200	70	22	13	4,5 - 6,0 / M6 / 6,3	20
Thermax 10/220 M6	514250 1) 2)	12	280	200 - 220	70	22	13	4,5 - 6,0 / M6 / 6,3	20
Thermax 10/240 M6	514251 1) 2)	12	300	220 - 240	70	22	13	4,5 - 6,0 / M6 / 6,3	20
Thermax 10/100 M8	045697 2)	12	160	80 - 100	70	22	13	M8	20
Thermax 10/120 M8	045698 2)	12	180	100 - 120	70	22	13	M8	20
Thermax 10/140 M8	045699 2)	12	200	120 - 140	70	22	13	M8	20
Thermax 10/160 M8	045700 2)	12	220	140 - 160	70	22	13	M8	20
Thermax 10/180 M8	514252 2)	12	240	160 - 180	70	22	13	M8	20
Thermax 10/200 M8	514253 2)	12	260	180 - 200	70	22	13	M8	20
Thermax 10/220 M8	514254 2)	12	280	200 - 220	70	22	13	M8	20
Thermax 10/240 M8	514255 2)	12	300	220 - 240	70	22	13	M8	20
Thermax 10/100 M10	045702 2)	12	160	80 - 100	70	22	13	M10	20
Thermax 10/120 M10	045703 2)	12	180	100 - 120	70	22	13	M10	20
Thermax 10/140 M10	045704 2)	12	200	120 - 140	70	22	13	M10	20
Thermax 10/160 M10	045705 2)	12	220	140 - 160	70	22	13	M10	20
Thermax 10/180 M10	514256 2)	12	240	160 - 180	70	22	13	M10	20
Thermax 10/200 M10	514257 2)	12	260	180 - 200	70	22	13	M10	20
Thermax 10/220 M10	514258 2)	12	280	200 - 220	70	22	13	M10	20
Thermax 10/240 M10	514259 2)	12	300	220 - 240	70	22	13	M10	20

1) including SX 5

2) Min. screw length $l_s = 22\text{mm} + \text{thickness of mounting member } e$; for use in wood without universal plug UX, consider drill hole diameter in footnote under load table.

Stand-off installation Thermax 12/16

The approved stand-off installation with thermal barrier in external thermal insulation composite systems (ETICS)

TECHNICAL DATA



Thermax 12/110 M12



Thermax 16/170 M12

	zinc-plated steel	stainless steel	Approval	Contents	Sales unit
	Art.-No.	Art.-No.	DIBt		[pcs]
Item	gvz	A4			
Thermax 12/110 M12	051291	—	●	20 Thermax M12, 20 perforated sleeves 20 x 130, 5 bit, 5 cutting blades, 5 user manuals	20
Thermax 12/110 M12	—	051537	●	10 Thermax M12 A4, 10 perforated sleeves 20 x 130, 3 bit, 3 cutting blades, 3 user manual	10
Thermax 12/110 M12 B	051290	—	●	2 Thermax M12, 2 perforated sleeves 20 x 130 , 1 bit, 1 cutting blade, 1 user manual	1
Thermax 16/170 M12	051293	—	●	20 Thermax M16, 20 perforated sleeves 20 x 200, 5 bit, 5 cutting blades, 5 applicator tip extension hoses, 5 user manuals	20
Thermax 16/170 M12	—	051543	●	10 Thermax M16 A4, 10 perforated sleeves 20 x 200, 3 bit, 3 cutting blades, 3 applicator tip extension hoses, 3 user manual	10
Thermax 16/170 M12 B	051292	—	●	2 Thermax M16, 2 perforated sleeves 20 x 200, 1 bit, 1 cutting blade, 1 applicator tip extension hose, 1 user manual	1

DUOPOWER The duo of power and intelligence

TECHNICAL DATA



DUOPOWER



DUOPOWER with greater anchorage depth

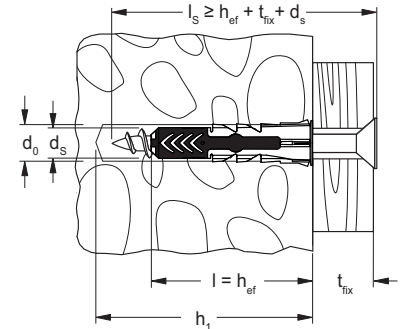

Item	Art.-No. without screw	Art.-No. with screw	Drill hole diameter	Min. drill hole depth	Min. panel thickness	Min. bolt penetra- tion	Anchor length	Wood and chipboard screws	Drive	Max. fixture thickness	Sales unit
			d_0 [mm]	h_1 [mm]	d_p [mm]	$l_{E,min}$ [mm]	l [mm]	$d_s / d_s \times l_s$ [mm]	t_{fix} [mm]	[pcs]	
DUOPOWER 5 x 25	555005	—	5	35	12,5	28	25	3 - 4	—	—	100
DUOPOWER 6 x 30	555006	—	6	40	12,5	34	30	4 - 5	—	—	100
DUOPOWER 8 x 40	555008	—	8	50	12,5	45	40	4,5 - 6	—	—	100
DUOPOWER 10 x 50	555010	—	10	60	12,5	56	50	6 - 8	—	—	50
DUOPOWER 5 x 25 S	—	555105	5	35	12,5	29	25	4 x 35	PZ2	6	50
DUOPOWER 6 x 30 S	—	555106	6	40	12,5	35	30	4,5 x 40	PZ2	5	50
DUOPOWER 8 x 40 S	—	555108	8	60	12,5	45	40	5 x 60	PZ2	15	50
DUOPOWER 10 x 50 S	—	555110	10	70	12,5	57	50	7 x 70	SW 13 / TX 40	13	25
DUOPOWER 6 x 50	538240	—	6	60	12,5	55	50	4 - 5	—	—	100
DUOPOWER 8 x 65	538241	—	8	75	2 x 12,5	70	65	4,5 - 6	—	—	50
DUOPOWER 10 x 80	538242	—	10	90	—	87	80	6 - 8	—	—	25
DUOPOWER 12 x 60	538243	—	12	70	—	68	60	8 - 10	—	—	25
DUOPOWER 14 x 70	538244	—	14	80	—	80	70	10 - 12	—	—	20
DUOPOWER 6 x 50 S	—	538245	6	75	12,5	55	50	4,5 x 70	PZ2	15	50
DUOPOWER 8 x 65 S	—	538246	8	85	2 x 12,5	70	65	5 x 80	PZ2	10	25
DUOPOWER 10 x 80 S	—	538247	10	112	—	87	80	7 x 107	SW 13	20	10
DUOPOWER 12 x 60 S	—	538248	12	85	—	68	60	8 x 80	SW 13	12	10
DUOPOWER 14 x 70 S	—	538249	14	100	—	80	70	10 x 95	SW 17	15	8

Universal plug UX

The nylon plug for all building materials

TECHNICAL DATA



UX - without rim



UX R - with rim



UX R S - with rim and screw

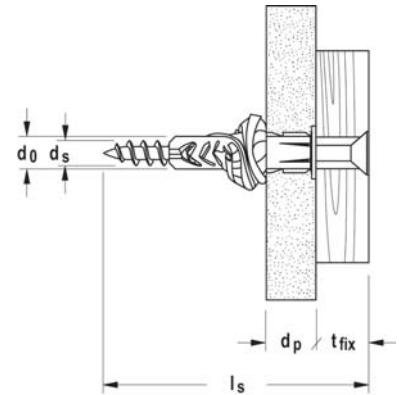
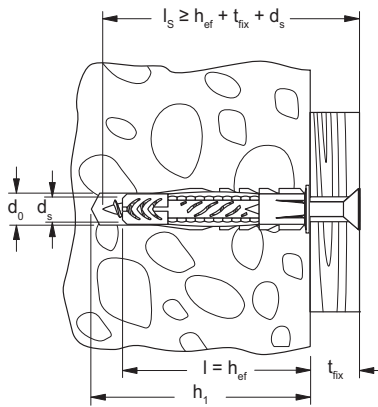

	without rim	with rim	with rim and screw	Drill hole diameter d_0	Min. drill hole depth h_1	Min. panel thickness d_p	Anchor length l	Wood and chip-board screws $d_s / d_s \times l_s$	Max. fixture thickness t_{fix}	Sales unit
Item	Art.-No. UX	Art.-No. UX R	Art.-No. UX R S	[mm]	[mm]	[mm]	[mm]	[mm]	[mm]	[pcs]
UX 5 x 30	094721	094722	—	5	40	9,5	30	3 - 4	—	100
UX 6 x 35	062754	062756	—	6	45	9,5	35	4 - 5	—	100
UX 6 x 35	—	—	094758	6	65	9,5	35	4,5 x 60	20	25
UX 6 x 50	072094	072095	—	6	60	9,5	50	4 - 5	—	100
UX 6 x 50	—	—	094759	6	80	9,5	50	4,5 x 75	20	25
UX 8 x 40	—	505483	—	8	50	9,5	40	4,5 - 6	—	100
UX 8 x 50	077869	077870	—	8	60	9,5	50	4,5 - 6	—	100
UX 8 x 50	—	—	094762	8	75	9,5	50	5 x 70	15	25
UX 8 x 50	—	—	094760	8	85	9,5	50	5 x 80	25	25
UX 10 x 60	077871	077872	—	10	75	12,5	60	6 - 8	—	50
UX 10 x 60	094761	—	—	10	90	12,5	60	6 x 85	20	10
UX 12 x 70	062758	—	—	12	85	—	70	8 - 10	—	25
UX 14 x 75	062757	—	—	14	95	—	75	10 - 12	—	20

Expansion plug SX The powerful nylon plug with 4-way expansion

TECHNICAL DATA



Plug **SX** with rim



Plug **SX** - with greater anchorage depth, without rim



Plug **SX** with rim and screw

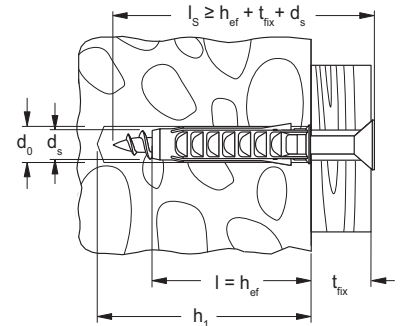

	with rim	with greater anchorage depth, without rim	with rim and screw	Drill hole diameter d_0 [mm]	Min. drill hole depth h_1 [mm]	Anchor length l [mm]	Wood and chip-board screws $d_s / d_s \times l_s$ [mm]	Max. fixture thickness t_{fix} [mm]	Sales unit [pcs]
Item	Art.-No. SX	Art.-No. SX	Art.-No. SX-S						
SX 4 x 20	070004	—	—	4	25	20	2 - 3	—	200
SX 5 x 25	070005	—	—	5	35	25	3 - 4	—	100
SX 6 x 30	070006	—	—	6	40	30	4 - 5	—	100
SX 6 x 30	—	—	070021	6	45	30	4,5 x 40	5	50
SX 6 x 50	078185	024827	—	6	60	50	4 - 5	—	100
SX 8 x 40	070008	—	—	8	50	40	4,5 - 6	—	100
SX 8 x 40	—	—	070022	8	65	40	5 x 60	15	50
SX 8 x 65	—	024828	—	8	75	65	4,5 - 6	—	50
SX 10 x 50	070010	—	—	10	70	50	6 - 8	—	50
SX 10 x 80	—	024829	—	10	95	80	6 - 8	—	25
SX 12 x 60	070012	—	—	12	80	60	8 - 10	—	25
SX 14 x 70	070014	—	—	14	90	70	10 - 12	—	20
SX 16 x 80	070016	—	—	16	100	80	12 (1/2")	—	10

One-component gun foam PUP BS 750

The gun foam with proven resistance to water pressure

TECHNICAL DATA



Item	Art.-No.	Content per can [ml]	Max. foam yield (free foaming) [l]	Colour	Sales unit [pcs]		
PUP BS 750 B2 (DE/EN)	513763	750	45	beige	12		

2-component rapid foam 2K PU 400

The high-quality 2-component rapid foam with high yield for secure fixing with pull activation

TECHNICAL DATA



Two-component fixing foam PU 2/402

Item	Art.-No.	Content per can [ml]	Max. foam yield (free foaming) [l]	Sales unit [pcs]			
2K PU 400 (DE)	053081	400	13	12			

2-component fixing foam

The 2-component fixing foam for professionals with high yield for secure fixing with rotation activation

TECHNICAL DATA



Item	Art.-No.	Content per can [ml]	Max. foam yield (free foaming) [l]	Sales unit [pcs]			
PU 2/403 B2 (DE)	053089	400	13	12			
2K PU S 400 (DE)	539199	400	13	12			

Without protective gloves, for commercial users only.

Premium sanitary silicone DSSA

The high-quality premium sanitary silicone

TECHNICAL DATA



Item	Art.-No.	Colour	Contents				
			[ml]	[pcs]			
DSSA TP (DE/EN)	053100	transparent	310	12			
DSSA W (DE/EN)	053101	white	310	12			
DSSA GR (DE/EN)	053102	grey	310	12			
DSSA BG (DE/EN)	053103	bahama beige	310	12			
DSSA DG (DE/EN)	053105	dark grey	310	12			
DSSA SW (DE/EN)	053120	black	310	12			
DSSA SG (DE/EN)	058530	silver grey	310	12			
DSSA FUG (DE/EN)	512208	joint grey	310	12			
DSSA SAG (DE/EN)	512209	sanitary grey	310	12			
DSSA MA (DE/EN)	512210	manhattan	310	12			
DSSA AN (DE/EN)	512211	anthracite	310	12			

Premium construction silicone DBSA

The low-odour premium construction silicone with high adhesive spectrum for metal processors

TECHNICAL DATA



Item	Art.-No.	Colour	Contents				
			[ml]	[pcs]			
DBSA TP (DE/EN)	053090	transparent	310	12			
DBSA GR (DE/EN)	053092	concrete grey RAL 7042	310	12			
DBSA SW (DE/EN)	053094	black RAL 9005	310	12			
DBSA ANG (DE/EN)	540084	anthracite grey RAL 7016	310	12			
DBSA WAL (DE/EN)	540086	white aluminium RAL 9006	310	12			
DBSA GAL (DE/EN)	540087	grey aluminium RAL 9007	310	12			

Construction sealant Premium DKM

The universal hybrid sealant/adhesive for indoor and outdoor use and HVAC systems

TECHNICAL DATA



Item	Art.-No.	Colour	Contents [ml]	Sales unit [pcs]				
DKM-290 ML (DE/EN)	517599	grey	290	12				

Premium all-weather sealant DDK

The permanently elastic joint sealant with a strong hold on all substrates

TECHNICAL DATA



Item	Art.-No.	Colour	Contents [ml]	Sales unit [pcs]				
DDK TR (DE/EN)	049103	transparent	310	12				

All-round adhesive gluing and sealing KD

The flexible adhesive and sealant for interior and exterior use with high initial tack even on wet surfaces

TECHNICAL DATA



All-round adhesive gluing and sealing KD-290

Item	Art.-No.	Contents [ml]	Type of packaging	Colour	Sales unit [pcs]			
KD WHITE 290ML	059389	290	Cartridge	white	12			
KD GREY 290ML (DE/EN)	503318	290	Cartridge	grey	12			
KD BLACK 290ML (DE/EN)	503319	290	Cartridge	black	12			

Zinc Spray FTC-ZS

Fast-drying surface and corrosion protection with outstanding long-term effect for metals

TECHNICAL DATA



Item	Art.-No.	Contents	Sales unit						
		[ml]	[pcs]						
FTC-ZS (EN/FR/ES/PT)	509242	400	12						

Accessories

TECHNICAL DATA



Plastic dispenser **PUPK 2**



Metal dispenser **PUPM 3**

Item	Art.-No.	Sales unit							
		[pcs]							
PUP K2	062400	1							
PUP M3	033208	1							
PUP M4 BLACK	513429	1							

TECHNICAL DATA



Item	Art.-No.	Contents	Sales unit					
		[ml]	[pcs]					
PUR 150 (DE)	053083	150	12					
PUR 500 (DE/EN)	053085	500	12					

TECHNICAL DATA



Skeleton dispenser **KPM 1**



Dispenser **KPM 2**



Dispenser **FIS DM S**

Item	Art.-No.	Sales unit [pcs]
KP M 1	053115	1
KP M 2	053117	1
FIS DM S	511118	1

TECHNICAL DATA



Pneumatic dispenser **FIS DP S-XL**



Dispenser **FIS DM S-L**



Dispenser **FIS AC**

Item	Art.-No.	Sales unit [pcs]
FIS DP S-XL	512401	1
FIS DM S-L	510992	1
FIS AC	096497	1

TECHNICAL DATA



Blow-out pump **ABG**

Item	Art.-No.	Sales unit [pcs]
Blow-out pump ABG	089300	1

ACCESSORIES DRILL HOLE CLEANING



Cleaning brush **BS**

Item	Art.-No.	Brush diameter [mm]	For drill diameter [mm]	Sales unit [pcs]
BS ø 8	078177	9	8	1
BS ø 10	078178	11	10	1
BS ø 12	078179	13	12	1
BS ø 14	078180	16	14	1
BS ø 16/18	078181	20	16/18	1
BS ø 24	078182	26	24	1
BS ø 28	078183	30	28	1
BS ø 35	078184	40	30/32/35	1

article	page	article	page	article	page
Air conditioner fixing KSU	254	Conduit clip BSM	278	Rubber inlay EMS	184
Air conditioner fixing MCE	252	Connector FCN Clix P and FCN Clix M	138	Saddle clip SCH	270
Angle brace WS 31-45°	94	Connector FCN Clix P hdg. / FCN Clix M hdg.	222	Saddle flange PSF	128
Angle bracket MW and MWU	108	Cross connector FVS	160	Saddle flange SF	144
Angle bracket MW Clix 90°	106	Double connector plate DPP, DPF	199	Saddle flange SF Clix 31	104
Angle bracket PWK	130	Duct hanger L- and Z-type	180	Saddle flange SF hdg.	225
Angle bracket WK	146	Fixpoint clamp FFPS and -saddle FFPK	169	Sanitary fixings for board materials	288
Angle bracket WK hdg.	227	Flanges FUF	155	Silicone pipe clamp FRSH	62
Base plate GPL	194	Flanges FUF hdg.	236	Sliding channel nut FSM Clix M	100
Beam Clamp Steel TKLS Steel Bite	190	Flanges FZF	154	Sliding channel nut FSM Clix P	98
Beam clamp TKR	151	Heavy duty pipe clamp FRSM - inch	68	Sliding element FSC1	172
Beam clamp TKR hdg.	231	Heavy duty pipe clamp FRSM - metric	70	Sliding element GL	170
Beam TKR 31	111	Hinged pipe clamp FGRS	50	Sliding hanger SB	173
Bracing elements PSAE	132	Hinged pipe clamp FGRS Plus	48	Sliding saddle SBS	171
Bracket FAF	153	Hinged pipe clamp FKS Plus for plastic pipes	52	Sound insulated fix point FSFP	168
Bracket FAF hdg.	235	Hole punch LZ, hole stamp LST	183	Spacer pipe clamp AM	276
Bracket FFF	152	Hose clamp SGS	84	Spiral duct hanger LRBN / LRB	181
Bracket FFF hdg.	233	Impact nail ED	207	Sprinkler clamp FRSL	80
Bracket PFAF	135	Installation Grid	156	Sprinkler clamp FRSP	78
Bracket PFFF	134	Large cantilever arm FCAM	124	Stud screw STST with torx	195
Bracket PFUF	136	Large cantilever arm FCAM hdg.	220	Support hanger AHB	196
Brackets PFUF D	137	Mounting bracket UWS	145	System components	161
Cable clasp KB	262	Mounting bracket UWS hdg.	226	Textile web strapping GWB	205
Cable harness SHA	264	Multi connector MW	197	Threaded rod bracket FSB 45°	150
Cable tie BN / UBN	282	Nail clip NS / MNS	272	Threaded rod bracket FSB 45° hdg.	230
Cantilever arm ALK	91	Nail disc NSB	274	Threaded rod G / Threaded stud GS	192
Cantilever arm FCA	120	Parallel connector PV	198	T-head bolt FHS Clix	102
Cantilever arm FCA hdg.	217	Pendulum hanger PDH / PDH K	174	T-head bolt FHS Clix S	140
Ceramic fixings	290	Perforated steel banding LBV / LBK	206	Universal bracket PUWS	129
Channel connector FUF OC and PFUF OC	119	Pipe clamp FRS	60	Universal mounting UHRS	148
Channel connector FUF OC hdg.	216	Pipe clamp FRS A2/A4	240	U-bolt ETR	77
Channel connector SV 31	96	Pipe clamp FRS Plus	54	U-Clamp FUBD	82
Channel FLS	88	Pipe clamp FRS Triple	58	Variable bracket PVB	131
Channel FUS	114	Pipe clamp FRSN	66	Variable bracket VB	149
Channel FUS hdg.	212	Pipe clamp FRSN Triple	64	Variable bracket VB hdg.	229
Channel nut FCN	142	Pipe clamp FRSN-L Universal	56	Ventilation duct clamp LGS	178
Channel washer HK 31	110	Pipe clip FC	268	Washbasin and urinal fixings	292
Channel washer HK 41	143	Pipe clip RC	266	Wireclip WIC	284
Channel washer HK 41 hdg.	224	Profile hanger TZ	182		
Clamp hanger TKL	188	Push-through connector PFCN	126		
ClipFix plus LS/ES/ZS	258	Refrigeration pipe clamp FRS K	72		
ClipFix plus SD	260	Refrigeration pipe clamp KFT	74		

art.-no.	article	page	art.-no.	article	page	art.-no.	article	page
004850	VB	149	037573	UBN 3,6 x 200	283	049459	FRSN 15 - 19 M8/M10	67
014319	VM M 6	202	040390	FUS 41/2,0 - 2 m	115	049479	UWS	145
014320	WDP 10 x 170	289	040391	FUS 21/2,0 - 2 m	115	049789	FRSN 21 - 23 M8/M10	67
014570	ED 22	208	040398	GPS M 12	194	049790	FRSN 25 - 28 M8/M10	67
015014	BSM 6	279	042535	FRS 15 - 19 M8/M10	61	049793	FRSN 32 - 36 M8/M10	67
015015	BSM 8	279	042536	FRS 20 - 24 M8/M10	61	049794	FRSN 38 - 43 M8/M10	67
015016	BSM 10	279	042537	FRS 25 - 30 M8/M10	61	049902	FRSN 44 - 49 M8/M10	67
015019	BSM 30	279	042538	FRS 32 - 37 M8/M10	61	049922	FRSN 50 - 56 M8/M10	67
015068	BSMD 10	279	042554	FRS 40 - 45 M8/M10	61	049944	FRSN 57 - 61 M8/M10	67
015069	BSMD 12	279	042555	FRS 55 - 61 M8/M10	61	049945	FRSN 63 - 70 M8/M10	67
015070	BSMD 14	279	043275	TKL Ø 13	189	049947	FRSN 70 - 77 M8/M10	67
015076	BSMD 26	279	043365	Toolset for SZE	208	049948	FRSN 80 - 83 M8/M10	67
015081	BSMD 42	279	044559	WIC 2 VE20	285	049979	FRSN 83 - 91 M8/M10	67
015082	BSMD 47	279	044560	WIC 2 VE100	285	050006	FRSN 100 - 106 M8/M10	67
018652	WB 5N	291	044561	WIC 3 VE20	285	050008	FRSN 108 - 114 M8/M10	67
020914	FHS CLIX S 8 x 30	141	044564	WIC 4 VE50	285	050009	FRSN 123 - 128 M8/M10	67
020915	FHS CLIX S 8 x 40	141	044565	WI Ø 2 mm	285	050010	FRSN 131 - 136 M8/M10	67
020916	FHS CLIX S 8 x 60	141	044721	WIZ	285	050023	FRSN 137 - 146 M8/M10	67
020917	FHS CLIX S 10 x 30	141	045517	SGS 9 W2 8 - 12	84	050326	KM 10	289
020918	FHS CLIX S 10 x 40	141	045518	SGS 9 W2 10 - 16	84	058120	RC IEC 16	267
020919	FHS CLIX S 10 x 60	141	045519	SGS 9 W2 12 - 20	84	058122	RC IEC 20	267
020936	RD M 8 / M 6	203	045520	SGS 9 W2 16 - 27	84	058135	KB 8	263
020947	PV M 6	198	045521	SGS 9 W2 20 - 32	84	058136	KB 16	263
020949	TKL M 12	189	045522	SGS 9 W2 25 - 40	84	058139	SHA 15	265
020956	G 6	192	045523	SGS 9 W2 32 - 50	84	058140	SHA 30	265
020957	G 12	192	045524	SGS 9 W2 40 - 60	84	058141	SHA MS	265
020958	G 16	192	045525	SGS 9 W2 50 - 70	84	058142	SHA KP	265
020959	GWB	205	045526	SGS 9 W2 60 - 80	84	058155	SF plus LS 3/13	259
020968	GPS 3/4"	194	045527	SGS 9 W2 70 - 90	84	058156	SF plus LS 8/28	259
020969	FHS CLIX S 12 x 30	141	045528	SGS 9 W2 80 - 100	84	058157	SF plus LS 20/40	259
020971	VM M 12	163	045529	SGS 9 W2 90 - 110	84	058173	NS 7	273
024415	ETR 8 - 13	77	045530	SGS 9 W2 100 - 120	84	058174	NS 8	273
024416	ETR 12 - 17	77	045531	SGS 9 W2 110 - 130	84	058175	NS 9	273
024417	ETR 15 - 21	77	045532	SGS 9 W2 120 - 140	84	058176	NS 10	273
024418	ETR 20 - 27	77	045956	WIS 2/1	285	058177	NS 12	273
024419	ETR 26 - 34	77	045957	WIS 2/2	285	058178	SF plus SD 30	261
024420	ETR 33 - 42	77	045958	WIS 2/3	285	058179	SF plus SD 40	261
024421	ETR 40 - 49	77	045959	WIS 2/5	285	058183	SF plus ES 28	259
024422	ETR 50 - 60	77	045960	WIS 2/10	285	058184	SF plus ZS 10	259
024423	ETR 60 - 70	77	047316	FHS CLIX S 12 x 40	141	058194	RC IEC 12	267
024424	ETR 66 - 76	77	047726	SBS 12/16	171	058198	RC IEC 25	267
024425	ETR 70 - 82	77	048151	SF plus ES 10	259	058199	RC IEC 32	267
024426	ETR 80 - 90	77	048152	SF plus ES 18	259	058200	RC IEC 40	267
024427	ETR 90 - 102	77	048154	SS-TKL M10/M12	189	060012	SCH 812	271
024428	ETR 100 - 108	77	048161	SF plus ZS 18	259	060016	SCH 1216	271
024429	ETR 102 - 114	77	048162	SF plus ZS 28	259	060019	SCH 1619	271
024430	ETR 121 - 127	77	048171	SF plus KB 8	263	060023	SCH 1623	271
024431	ETR 126 - 133	77	048172	SF plus KB 16	263	060032	SCH 2332	271
024432	ETR 131 - 140	77	048181	SF plus MS	265	060042	SCH 3242	271
024433	ETR 143 - 153	77	048190	SF plus RC IEC 12	267	060149	BSM 16	279
024434	ETR 150 - 159	77	048191	SF plus RC IEC 16	267	060150	BSM 18	279
024435	ETR 168	77	048193	SF plus RC IEC 20	267	060151	BSM 20	279
024436	ETR 193,7	77	048197	SF plus RC IEC 25	267	060152	BSM 22	279
024437	ETR 219	77	048198	SF plus RC IEC 32	267	060153	BSM 24	279
024637	LGS 450	179	048199	SF plus RC IEC 40	267	060155	BSM 28	279
024638	LGS 500	179	048212	ED 15	208	060158	BSM 37	279
024639	LGS 560	179	048308	NSB 2/40	275	060169	BSMD 16	279
024640	LGS 600	179	048309	NSB 2/50	275	060170	BSMD 18	279
024641	LGS 630	179	048310	NSB 2/60	275	060171	BSMD 20	279
024642	LGS 710	179	048311	NSB 3/40	275	060172	BSMD 22	279
024643	LGS 800	179	048312	NSB 3/50	275	060175	BSMD 28	279
024644	LGS 900	179	048313	NSB 3/60	275	060178	BSMD 37	279
024645	LGS 1000	179	048510	FFPS 2"	169	060185	AM 8	277
024646	LGS 1120	179	048511	FFPS 2 1/2"	169	060186	AM 10	277
024647	LGS 1250	179	048512	FFPS 3"	169	060187	AM 12	277
024648	DPF 60 - 105	199	048513	FFPS 4"	169	060188	AM 14	277
024649	U 12 x 40	162	048660	FFPS 5"	169	060189	AM 16	277
024650	MU M 12	162	048662	FFPS 159 - 166	169	060190	AM 18	277
024671	LKH	180	048663	FFPS 6"	169	060191	AM 20	277
024674	ZKH	180	048664	FFPS 8"	169	060192	AM 22	277
024675	LRB	181	048665	FFPS 10"	169	060193	AM 24	277
037289	GPR 1/2"	194	048666	FFPK	169	060194	AM 26	277

art.-no.	article	page	art.-no.	article	page	art.-no.	article	page
060195	AM 28	277	064901	FRS 133 - 141 A4	240	077716	STS 10 x 100 A4	246
060196	AM 30	277	064903	FRS 159 - 168 A4	240	079194	RC IEC 50	267
060200	BU M8 MH	294	064905	MS 27/18 A2 - 2m	241	079196	RC IEC 63	267
060201	BU M10 MH	294	064975	FHS CLIX 10 x 30 A2	241	079400	FGRS Plus 12 - 14	49
060204	BU M12 MH	294	064977	HG 27 M 10 A2	242	079401	FGRS Plus 15 - 19	49
060209	AM 32	277	065101	ALK 27/18 - 200 A2	241	079402	FGRS Plus 20 - 24	49
060210	AM 34	277	065132	STS 8 x 80 A2	246	079403	FGRS Plus 25 - 30	49
060211	AM 37	277	065153	STS 10 x 100 A2	246	079404	FGRS Plus 32 - 37	49
060561	WCN 1	291	065173	G 10 A2	247	079405	FGRS Plus 40 - 44	49
060562	WCN 2	291	065174	G 10 A4	247	079406	FGRS Plus 45 - 50	49
060564	S 8 D 70 WCR	291	068012	SCH 812 GR	271	079407	FGRS Plus 50 - 55	49
060568	S 8 RD 80 WCR	291	068016	SCH 1216 GR	271	079408	FGRS Plus 56 - 63	49
060570	S 8 RD 60 WCR	291	068019	SCH 1619 GR	271	079413	RDM M 10 / M 8	204
063490	FRSH 15 - 19	63	068023	SCH 1623 GR	271	079414	RDM M 12 / M 10	204
063492	FRSH 20 - 24	63	068032	SCH 2332 GR	271	079415	SKS 8 x 16	201
063494	FRSH 25 - 30	63	068060	FC 6 - 9 GR	269	079416	SKS 10 x 20	201
063495	FRSH 32 - 37	63	068062	FC 9 - 12 GR	269	079417	SKS 10 x 30	201
063498	FRSH 40 - 45	63	068064	FC 12 - 16 GR	269	079420	FGRS 12 - 14	51
063499	FRSH 48 - 53	63	068066	FC 16 - 20 GR	269	079421	FGRS 15 - 19	51
063500	FRSH 54 - 59	63	068267	PDH K M 8	174	079422	FGRS 20 - 24	51
063502	FRSH 60 - 64	63	068269	PDH K M 10	174	079423	FGRS 25 - 30	51
063504	FRSH 68 - 73	63	069364	UBN 3,6 x 300	283	079424	FGRS 32 - 37	51
063505	FRSH 72 - 78	63	069367	UBN 4,8 x 250	283	079425	FGRS 40 - 44	51
063511	FRSH 80 - 86	63	069368	UBN 4,8 x 350	283	079426	FGRS 45 - 50	51
063513	FRSH 89 - 92	63	069369	UBN 4,8 x 370	283	079427	FGRS 50 - 55	51
063518	FRSH 95 - 103	63	069370	UBN 4,8 x 430	283	079428	FGRS 56 - 63	51
063520	FRSH 102 - 116	63	069374	UBN 7,6 x 450	283	079430	FGRS Plus 12 - 14 M8/M10	49
063537	FRSH 133 - 141	63	069375	UBN 7,6 x 550	283	079431	FGRS Plus 15 - 19 M8/M10	49
063559	WK 100/100	146	069376	UBN 8,8 x 760	283	079432	FGRS Plus 20 - 24 M8/M10	49
063938	UHRS	148	069377	UBN 8,8 x 810	283	079433	FGRS Plus 25 - 30 M8/M10	49
064037	PDH M 12	174	069379	UBN 8,8 x 1168	283	079434	FGRS Plus 32 - 37 M8/M10	49
064038	GLL 3/4"	170	071269	FSB 45°	150	079435	FGRS Plus 40 - 44 M8/M10	49
064041	GL 3/4"	170	071750	VB fVz	229	079436	FGRS Plus 45 - 50 M8/M10	49
064055	TKL L M 8	189	077347	FUS 41/2,5 - 3 m	115	079437	FGRS Plus 50 - 55 M8/M10	49
064056	G 12/3	162	077349	FUS 21/2,5 - 3 m	115	079438	FGRS Plus 56 - 63 M8/M10	49
064090	SPS M 12	163	077355	FEC 41 B	125	079440	FRS Plus 12 - 15	55
064091	BLR 100 M12	163	077357	FEC 21 B	125	079441	FRS Plus 15 - 19	55
064093	G 1/2"	192	077359	FCA 41 - 300	121	079442	FRS Plus 20 - 24	55
064094	TZ M 8	182	077361	FCA 41 - 450	121	079443	FRS Plus 25 - 30	55
064095	TZ M 10	182	077363	FCA 41 - 600	121	079444	FRS Plus 32 - 37	55
064290	FRS 3/8" A2	240	077365	FCA 41 - 750	121	079445	FRS Plus 40 - 45	55
064536	FRS 1/2" A2	240	077405	FCN 6	142	079446	FRS Plus 48 - 54	55
064639	FRS 3/4" A2	240	077407	FCN 8	142	079447	FRS Plus 55 - 61	55
064646	FRS 1" A2	240	077409	FCN 10	142	079449	FRS Plus 63 - 67	55
064669	FRS 1 1/4" A2	240	077411	FCN 12	142	079450	FRS Plus 68 - 73	55
064673	FRS 1 1/2" A2	240	077537	FUS 41/2,5 - 6 m	115	079451	FRS Plus 72 - 80	55
064674	FRS 54 - 58 A2	240	077541	FUS 21/2,5 - 6 m	115	079452	FRS Plus 80 - 86	55
064675	FRS 2" A2	240	077580	G 3/4"	192	079453	FRS Plus 87 - 92	55
064688	FRS 67 - 71 A2	240	077605	TKL L Ø 9	189	079454	FRS Plus 95 - 103	55
064689	FRS 2 1/2" A2	240	077606	GRD 3/4" / M 12	204	079455	FRS Plus 108 - 116	55
064693	FRS 81 - 86 A2	240	077607	GRD 3/4" / M 10	204	079456	FRS 121 - 128 M8/M10	61
064694	FRS 3" A2	240	077608	GRD 1/2" / M 12	204	079457	FRS 133 - 141 M8/M10	61
064695	FRS 95 - 103 A2	240	077609	GRD 1/2" / M 10	204	079458	FRS 159 - 165 M8/M10	61
064697	FRS 4" A2	240	077613	LRBN	181	079459	FRS 165 - 168 M8/M10	61
064709	FRS 121 - 127 A2	240	077615	SF L 27 A2	242	079470	FKS Plus 15 - 19	53
064713	FRS 133 - 141 A2	240	077625	MW 27-90° A2	242	079471	FKS Plus 20 - 24	53
064714	FRS 159 - 168 A2	240	077626	MW 27-45° A2	242	079472	FKS Plus 25 - 30	53
064864	FRS 3/8" A4	240	077634	FHS CLIX 8 x 30 A2	241	079473	FKS Plus 32 - 37	53
064865	FRS 1/2" A4	240	077636	HG 27 M 8 A2	242	079474	FKS Plus 40 - 44	53
064866	FRS 3/4" A4	240	077641	MU M 10 A4	248	079475	FKS Plus 45 - 50	53
064868	FRS 1" A4	240	077642	MU M 8 A4	248	079476	FKS Plus 50 - 55	53
064869	FRS 1 1/4" A4	240	077643	STS 8 x 100 A2	246	079477	FKS Plus 56 - 63	53
064870	FRS 1 1/2" A4	240	077644	G 8 A2	247	079491	LGS 80	179
064873	FRS 54 - 58 A4	240	077645	G 8 A4	247	079492	LGS 90	179
064874	FRS 2" A4	240	077689	STST 10 x 60	195	079493	LGS 100	179
064875	FRS 67 - 71 A4	240	077707	STST 10 x 80	195	079494	LGS 112	179
064879	FRS 2 1/2" A4	240	077708	STST 10 x 100	195	079495	LGS 125	179
064892	FRS 81 - 86 A4	240	077709	STST 10 x 120	195	079496	LGS 140	179
064893	FRS 3" A4	240	077711	STST 10 x 140	195	079497	LGS 150	179
064894	FRS 95 - 103 A4	240	077712	STST 10 x 180	195	079498	LGS 160	179
064898	FRS 4" A4	240	077714	STST 6 x 80	195	079499	LGS 180	179
064899	FRS 121 - 127 A4	240	077715	STS 8 x 100 A4	246	079500	LGS 200	179

art.-no.	article	page	art.-no.	article	page	art.-no.	article	page
079501	LGS 224	179	079753	GS 8/60	192	091478	U 10 x 21	201
079502	LGS 250	179	079754	GS 8/70	192	091488	FRS 63 - 67 M8/M10	61
079503	LGS 280	179	079755	GS 8/80	192	091489	FRS 72 - 80 M8/M10	61
079504	LGS 300	179	079757	GS 8/100	192	091505	FRS 87 - 92 M8/M10	61
079505	LGS 315	179	079758	GS 8/150	192	091506	FRS 108 - 116 M8/M10	61
079506	LGS 355	179	079759	GS 8/200	192	091507	FRSH 159 - 168	63
079507	LGS 400	179	079765	GS 10/25	192	092295	FUS 41/2,5 - 2 m	115
079535	BSMZ 20	279	079766	GS 10/40	192	092867	FUS 21/2,5 - 2 m	115
079536	BSMZ 24	279	079767	GS 10/60	192	093700	FRSM 1 1/2" M10/M12	71
079537	BSMZ 28	279	079768	GS 10/80	192	093701	FRSM 53 - 58 M10/M12	71
079549	LBV 12	206	079769	GS 10/100	192	093702	FRSM 2" M10/M12	71
079550	LBV 17	206	079770	GS 10/120	192	093703	FRSM 2 1/2" M10/M12	71
079551	LBV 25	206	079771	GS 10/150	192	093704	FRSM 3" M10/M12	71
079553	LBK 14	206	079772	GS 10/200	192	093705	FRSM 102 M10/M12	71
079554	LBK 19	206	079780	STST 8 x 50	195	093707	FRSM 4" M10/M12	71
079555	LBK 27	206	079781	STST 8 x 60	195	093709	FRSM 124 - 129 M10/M12	71
079570	WK 200/200	146	079782	STST 8 x 80	195	093710	FRSM 133 M10/M12	71
079571	WK 207/165	146	079783	STST 8 x 100	195	093711	FRSM 5" M10/M12	71
079665	GPL M 8	194	079784	STST 8 x 120	195	093712	FRSM 160 M10/M12	71
079666	GPL M 10	194	079785	STST 8 x 140	195	093713	FRSM 6" M10/M12	71
079667	GPL 1/2"	194	079786	STST 8 x 180	195	093714	FRSM 7" M10/M12	71
079671	GPS M 10	194	079815	ED 18	208	093715	FRSM 200 M10/M12	71
079672	GPS 1/2"	194	079820	SZE	208	094673	MNS 4-7	273
079675	AHB	196	079825	TZH M 8	182	094674	MNS 7-11	273
079676	PDH M 8	174	079826	TZH M 10	182	094675	MNS 10-14	273
079677	PDH M 10	174	079827	SKS 8 x 100	201	096958	BSM 26	279
079678	PV M 8	198	079829	LST 10	183	097658	FUS 41/2,0 - 3 m	115
079680	SB M 8	173	079830	LZ	183	097659	FUS 41/2,0 - 6 m	115
079681	SB M 10	173	079831	HED	200	097660	FUS 21/2,0 - 3 m	115
079685	SBS M 8	171	080650	WL 10 x 80	294	097661	FUS 21/2,0 - 6 m	115
079686	SBS M 10	171	080651	WL 7 x 60	294	500698	FRS Triple 15 - 19	59
079687	TKL M 8	189	080652	WL 8 x 70	294	500699	FRS Triple 21 - 23	59
079688	TKL M 10	189	080654	BO 120	293	500700	FRS Triple 26 - 28	59
079689	TKL Ø 11	189	080655	WD 10 x 120	293	500701	FRS Triple 32 - 35	59
079690	VM M 8	202	080656	WD 10 x 140	293	500702	FRS Triple 40 - 43	59
079691	VM M 10	202	080658	WD 8 x 110	293	500703	FRS Triple 48 - 56	59
079692	RD M 10 / M 8	203	080659	WD 8 x 90	293	500704	FRS Triple 57 - 62	59
079693	RD M 12 / M 10	203	080660	WST 10 x 140	293	500705	FRS Triple 63 - 70	59
079694	RD M 6 / M 8	203	080661	WST 12 x 150	293	500706	FRS Triple 74 - 80	59
079695	RD 1/2" / M10	203	080662	WST 12 x 180	293	500707	FRS Triple 83 - 91	59
079696	AG 8 x 25	202	080668	UST 10 x 120	293	500708	FRS Triple 100 - 105	59
079697	AG 10 x 25	202	080951	AKM 10 CR	294	500709	FRS Triple 108 - 114	59
079698	RAH M 8	203	080952	AKM 12 CR	294	500710	FRS Triple 115 - 125	59
079699	RAH M 10	203	080972	AKM 10 W	294	500711	FRS Triple 127 - 135	59
079700	LLS 6 x 50	204	083578	UST 8 x 110	293	500712	FRS Triple 135 - 140	59
079701	LLS 8 x 50	204	087488	UBN 2,5 x 100	283	500713	FRS Triple 159 - 169	59
079702	DPP 65	199	087489	UBN 2,5 x 120	283	500714	FRSN Triple 15 - 19	65
079703	DPP 85	199	087490	UBN 2,5 x 200	283	500715	FRSN Triple 21 - 23	65
079704	DPP 105	199	087491	UBN 3,6 x 150	283	500716	FRSN Triple 26 - 28	65
079705	SBB 35	200	087494	UBN 4,6 x 200	283	500717	FRSN Triple 32 - 35	65
079706	SBB 45	200	087495	UBN 4,8 x 280	283	500718	FRSN Triple 40 - 43	65
079707	SBB 55	200	087497	UBN 7,6 x 350	283	500719	FRSN Triple 48 - 56	65
079711	SKS 6 x 20	201	090839	BSM 25	279	500720	FRSN Triple 57 - 62	65
079713	SKS 8 x 30	201	090840	BSM 32	279	500721	FRSN Triple 63 - 70	65
079714	SKS 8 x 45	201	090841	BSM 40	279	500722	FRSN Triple 74 - 80	65
079715	SKS 8 x 55	201	090842	BSM 50	279	500723	FRSN Triple 83 - 91	65
079717	MW M 8	197	090843	BSM 63	279	500724	FRSN Triple 100 - 105	65
079721	SKS 10 x 55	201	090844	BSMD 25	279	500725	FRSN Triple 108 - 114	65
079725	U 8 x 28	201	090845	BSMD 32	279	500744	FRSN 118 - 122 M8/M10	67
079726	U 10 x 28	201	090846	BSMD 40	279	500746	FRSN 146 - 156 M8/M10	67
079729	U 8 x 40	201	090847	BSMD 50	279	500747	FRSN 159 - 165 M10/M12	67
079730	U 10 x 40	201	090848	BSMD 63	279	500748	FRSN 166 - 175 M10/M12	67
079733	MU M 6	202	090849	AM 40	277	500751	FRSN 200 - 206 M10/M12	67
079734	MU M 8	202	090850	AM 50	277	500752	FRSN 210 - 219 M10/M12	67
079735	MU M 10	202	091442	GS 12/40	193	504315	FCA 62 - 1000	121
079740	G 8	192	091443	GS 12/60	193	504317	FCA 41D - 750	121
079741	G 8/2	192	091444	GS 12/80	193	504319	FCA 41D - 1000	121
079744	G 10	192	091461	GS 12/100	193	504320	FHS CLIX S 12 x 60	141
079745	G 10/2	192	091462	GS 12/120	193	504326	FCN Clix P 6	139
079750	GS 8/25	192	091463	GS 12/150	193	504327	FCN Clix P 8	139
079751	GS 8/40	192	091464	GS 12/200	193	504329	FCN Clix P 10	139
079752	GS 8/50	192	091477	U 8 x 17	201	504331	FCN Clix P 12	139

art.-no.	article	page	art.-no.	article	page	art.-no.	article	page
504344	FCN Clix M 6	139	505458	FRSM 12" M12/M16	71	506493	FRS K 48-49/13	73
504345	FCN Clix M 8	139	505460	FCAM 700	124	506494	FRS K 60/13	73
504346	FCN Clix M 10	139	505487	FCA 41 A4 - 300	243	506495	FRS K 12/19	73
504347	FCN Clix M 12	139	505488	FCA 41 A4 - 450	243	506496	FRS K 15/19	73
504348	HK 41 8,5	143	505489	FCA 41 A4 - 600	243	506497	FRS K 17-18/19	73
504349	HK 41 10,5	143	505536	GS 8/40 A4	247	506498	FRS K 21-22/19	73
504354	HK 41 12,5	143	505537	GS 8/60 A4	247	506499	FRS K 27-28/19	73
504355	SF L 41	144	505538	GS 10/40 A4	247	506500	FRS K 34-35/19	73
504357	SF L 82	144	505539	GS 10/60 A4	247	506501	FRS K 42/19	73
504358	SF L 124	144	505540	VM M8 A4	247	506502	FRS K 48-49/19	73
504363	TKR 21 - 42	151	505541	VM M10 A4	247	506503	FRS K 60/19	73
504366	TKR 82	151	505542	U 8 x 28 A4	248	506504	FRS K 64/19	73
504367	TKR 124	151	505543	U 8 x 40 A4	248	506505	FRS K 70/19	73
504368	FFF 4D	152	505544	U 10 x 28 A4	248	506506	FRS K 76/19	73
504375	FZF 21	154	505545	U 10 x 40 A4	248	506508	FRS K 89/19	73
504376	FUF 21	154	505546	U 12 x 24 A4	248	506509	FRS K 102/19	73
504377	FUF 41	154	505547	SKS M 10 x 30 A4	248	506510	FRS K 108/19	73
504378	FUF 4Y	155	505548	SKS M 12 x 30 A4	248	506511	FRS K 114/19	73
504379	FUF 180°L	155	505549	FVS 3	160	507699	FRS K 54/13	73
504383	FUF 180°R	155	505550	FVS 4	160	507700	FRS K 54/19	73
504387	FUF 8T	155	505551	FEC 62 B	125	507786	FRS K 133/19	73
504397	RD M 12 / M 16	203	505552	SKS 10 x 85	201	507787	FRS K 139/19	73
504399	RD M 16 / M 12	203	505553	SKS 12 x 85	201	507788	FRS K 168/19	73
504400	STST 6 x 60	195	505576	KFT 9,5	75	507866	FSC 1	172
504408	GPS M 16	194	505577	KFT 12,7	75	508833	VM M 16	202
504436	FCN Clix P 8 A4	246	505578	KFT 15,8	75	510969	FRS 12 - 15 M8/M10	61
504437	FCN Clix P 10 A4	246	505579	KFT 17,2	75	510970	FRS 48 - 54 M8/M10	61
504439	FCN Clix P 12 A4	246	505580	KFT 18,0	75	512709	KSU S 440	255
504440	FCN Clix M 8 A4	246	505581	KFT 19,5	75	512710	KSU S 520	255
504447	FCN Clix M 10 A4	246	505582	KFT 21,3	75	512711	KSU S 600	255
504457	FUS 62/2,5 - 6 m	115	505583	KFT 22,0	75	512712	KSU 440	255
504458	FUS 21D/2,0 - 3 m	115	505584	KFT 26,9	75	512713	KSU 520	255
504459	FUS 41D/2,5 - 6 m	115	505585	KFT 28,0	75	512714	KSU 600	255
504460	FUS 62D/2,5 - 6 m	115	505587	KFT 33,7	75	512715	PA 30 x 30	255
504466	FUS 21/2,0 A2 - 2 m	243	505588	KFT 35,0	75	512716	FSFP 1"	168
504468	FUS 41/2,0 A2 - 2 m	243	505589	KFT 40,0	75	512717	FSFP 1 1/4"	168
504470	FUS 41/2,5 A2 - 2 m	243	505591	KFT 41,2	75	512718	FSFP 1 1/2"	168
504472	FUS 21/2,0 A4 - 2 m	243	505592	KFT 42,4	75	512719	FSFP 2"	168
504474	FUS 41/2,0 A4 - 2 m	243	505593	KFT 44,5	75	512720	FSFP 2 1/2"	168
504475	FUS 41/2,5 A4 - 2 m	243	505594	KFT 48,3	75	512721	FSFP 3"	168
504476	TKR 21 - 42 A4	245	505595	KFT 50,0	75	512722	FSFP 4"	168
504477	FCAM 300	124	505596	KFT 54,0	75	513302	FRSL 34	81
504479	FCAM 400	124	505597	KFT 57,0	75	513303	FRSL 43	81
504480	FCAM 500	124	505598	KFT 60,3	75	513304	FRSL 49	81
504482	FCAM 600	124	505599	KFT 64,0	75	513307	FRSL 60	81
504489	HK 41 12,5 - A4	245	505901	KFT 70,0	75	513308	FRSL 76	81
504494	FFF 1	152	505902	KFT 74,0	75	513309	FRSL 90	81
504498	FFF 3L	152	505903	KFT 76,1	75	513310	FRSL 115	81
504499	FFF 4	152	505904	KFT 80,0	75	513311	FRSL 140	81
504500	FFF 4T	152	505905	KFT 84,0	75	513312	FRSL 170	81
504515	FZF 41	154	505906	KFT 88,9	75	516537	LKHN	180
504517	FUF OC 41	119	505907	KFT 92,1	75	516540	ZKHN	180
504518	FUF OC 62	119	505908	KFT 101,0	75	517411	FCA 41 - 300 fvz	218
504519	FAF 2 A4	244	505909	KFT 104,0	75	517412	FCA 41 - 450 fvz	218
504520	FAF 4 A4	244	505910	KFT 108,0	75	517413	FCA 41 - 600 fvz	218
504521	FAF 2/135° A4	244	505911	KFT 114,3	75	517414	FCA 41 - 750 fvz	218
504522	SF L 41 A4	244	505914	KFT 129,0	75	517415	FUF OC 41 fvz	216
504589	FRSM 1/2" M10/M12	71	505915	KFT 133,0	75	517420	FCN Clix P 12 fvz	223
504590	FRSM 3/4" M10/M12	71	505916	KFT 139,7	75	517421	SF L 41 fvz	225
504591	FRSM 1" M10/M12	71	505917	KFT 154,0	76	517426	FUS 41/2,0 - 3 m fvz	213
504592	FRSM 1 1/4" M10/M12	71	505918	KFT 159,0	76	517427	FUS 62/2,5 - 3 m fvz	213
504593	FRSM 79 - 85 M10/M12	71	505919	KFT 168,3	76	517428	FUS 62/2,5 - 6 m fvz	213
504594	FRSM 348 - 356 M16	71	505920	KFT 193,7	76	521760	KLIMA EASY KLIK	253
504595	FRSM 364 - 372 M16	71	505921	KFT 204,0	76	521761	KLIMA KLIK 420	253
504596	FRSM 400 - 409 M16	71	505922	KFT 219,1	76	524035	FRSP 1/2"	79
504597	FRSM 454 - 462 M16	71	506486	FRS K 12/13	73	524036	FRSP 3/4"	79
504598	FRSM 500 - 508 M16	71	506487	FRS K 15/13	73	524037	FRSP 1"	79
505453	FRSM 212 M12/M16	71	506488	FRS K 17-18/13	73	524038	FRSP 1 1/4"	79
505454	FRSM 8" M12/M16	71	506489	FRS K 21-22/13	73	524039	FRSP 1 1/2"	79
505455	FRSM 250 M12/M16	71	506490	FRS K 27-28/13	73	524040	FRSP 2"	79
505456	FRSM 10" M12/M16	71	506491	FRS K 34-35/13	73	524041	FRSP 2 1/2"	79
505457	FRSM 300 M12/M16	71	506492	FRS K 42/13	73	524042	FRSP 3"	79

art.-no.	article	page	art.-no.	article	page	art.-no.	article	page
524043	FRSP 4"	79	537576	FAF 2 fvz	153	538667	MWU 90°	109
524044	FRSP 5"	79	537577	FAF 3 fvz	153	538668	MW 90°	109
524045	FRSP 6"	79	537578	FAF 4 fvz	153	538738	ALK 17-200	91
524046	FRSP 8"	79	537579	FAF 2/135° fvz	153	538739	ALK 17-300	91
524047	TZA M10	182	537580	FFF 1 fvz	234	538740	ALK 30-200	91
531134	TKLS Ø 9	191	537581	FFF 3L fvz	234	538741	ALK 30-300	91
531136	TKLS Ø 11	191	537582	FFF 4 fvz	234	538742	ALK 30-450	91
531137	TKLS Ø 13	191	537583	FFF 4T fvz	234	538743	ALK 37-300	91
531138	TKLS Ø 17	191	537584	FFF 4D fvz	234	538744	ALK 37-450	91
533731	PUWS 2 x 2/135°	129	537585	FUF 4Y fvz	237	538745	ALK 37-600	91
533733	PUWS 2 x 2	129	537586	FUF 4Y fvz	237	538746	AK 17	93
533734	PUWS 4 x 4	129	537587	FUF 180°R fvz	237	538747	AK 30	93
533735	PFAF 2	135	537588	FUF 21 fvz	236	538748	AK 37	93
533736	PFAF 3	135	537589	FUF 41 fvz	236	538749	WS 31-45°	95
533737	PFAF 4/135°	135	537590	FUF 8T fvz	237	538751	TKR 31	111
533738	PFUF 41	136	537591	FUF OC 62 fvz	216	538752	EMS 31	184
533739	PFCN 41	126	537653	FUS 21/2,0 - 3 m fvz	213	538753	FLS 17/1,0 - 2 m	89
533740	PSF 41	128	537656	FUS 41/2,0 - 6 m fvz	213	538754	FLS 17/1,0 - 3 m	89
533741	PSF 82	128	537658	FUS 41/2,5 - 6 m fvz	213	538755	FLS 30/1,0 - 2 m	89
533742	PSF 124	128	537659	FUS 21D/2,0 - 3 m fvz	213	538756	FLS 30/1,0 - 3 m	89
533743	PFUF OC	119	537661	FUS 21D/2,0 - 6 m fvz	213	538757	FLS 37/1,2 - 2 m	89
533744	PWK 200/200	130	537662	FUS 41D/2,5 - 6 m fvz	213	538758	FLS 37/1,2 - 3 m	89
533745	PFFF 2L	134	537663	FUS 62D/2,5 - 6 m fvz	213	538759	FLS 37/1,2 - 6 m	89
534960	PVB	131	538015	FCA 62 - 1000 fvz	218	539443	FRS-L 8 - 11 Universal	57
535266	PSFQ 41	128	538016	FCA 41D - 750 fvz	218	539444	FRS-L 12 - 15 Universal	57
535267	PFAF 4	135	538017	FCA 41D - 1000 fvz	218	539445	FRS-L 16 - 19 Universal	57
535268	PFFF 4I	134	538018	FCAM 300 fvz	220	539446	FRS-L 20 - 24 Universal	57
535269	PSAE 300 Stütze	133	538019	FCAM 400 fvz	220	539447	FRS-L 25 - 30 Universal	57
535270	PSAE 500 Stütze	133	538020	FCAM 500 fvz	220	539448	FRS-L 31 - 37 Universal	57
535271	PU 10,5 U-Scheibe	133	538021	FCAM 600 fvz	220	539449	FRS-L 38 - 45 Universal	57
535272	PU 12,5 U-Scheibe	133	538022	FCAM 700 fvz	220	539450	FRS-L 46 - 52 Universal	57
535273	PFUF 3DL	137	538080	RD M 16 / M 12 lang	203	539451	FRS-L 53 - 59 Universal	57
535274	PFUF 3DR	137	538082	FRSL 34 M8	81	539452	FRS-L 60 - 66 Universal	57
535275	PFUF 4D	137	538083	FRSL 43 M8	81	539453	FRS-L 67 - 75 Universal	57
535494	FRSM 3/8"	69	538084	FRSL 49 M8	81	539454	FRS-L 76 - 84 Universal	57
535497	FRSM 1/2"	69	538085	FRSL 60 M8	81	539455	FRS-L 85 - 93 Universal	57
535498	FRSM 3/4"	69	538106	FCN Clix P 8 fvz	223	539456	FRS-L 94 - 100 Universal	57
535499	FRSM 1"	69	538107	FCN Clix P 10 fvz	223	539457	FRS-L 101 - 110 Universal	57
535500	FRSM 1 1/4"	69	538108	FCN Clix M 8 fvz	223	539459	FRS-L 111 - 119 Universal	57
535501	FRSM 1 1/2"	69	538109	FCN Clix M 10 fvz	223	539477	FRS K 219/19	73
535502	FRSM 2"	69	538110	FCN Clix M 12 fvz	223	539564	FUBD 40	83
535503	FRSM 2 1/2"	69	538113	HK 41 10,5 fvz	224	539566	FUBD 52	83
535504	FRSM 3"	69	538114	HK 41 12,5 fvz	224	539567	FUBD 60	83
535505	FRSM 110 mm	69	538115	UWS fvz	226	539568	FUBD 76	83
535506	FRSM 4"	69	538117	WK 100/100 fvz	227	539569	FUBD 94	83
535507	FRSM 133 mm	69	538118	WK 200/200 fvz	227	539570	FUBD 100	83
535508	FRSM 5"	69	538120	FSB 45° fvz	230	550806	EMS 41	184
535509	FRSM 160 mm	69	538122	TKR 21- 42 fvz	231	557092	G 10/3	192
535511	FRSM 6"	69	538123	TKR 82 fvz	231	557270	G 24	192
535531	FUS 21D/2,0 - 6 m	115	538124	TKR 124 fvz	231	557295	G 20	192
535532	MU M 20	202	538125	SF L 82 fvz	225	557297	MU M 16	202
535534	MU M 24	202	538126	SF L 124 fvz	225	557301	U 12 x 24	201
535535	GS 8/120	192	538641	SV 31	97	557303	U 16 x 30	201
535536	GS 8/180	192	538643	FSM Clix P 6	99	579746	G 12/2	192
535537	SKS 10 x 65	201	538647	FSM Clix P 8	99			
535538	SKS 12 x 25	201	538649	FSM Clix P 10	99			
535539	SKS 12 x 65	201	538650	FSM Clix M 6	101			
535540	U 16 x 40	201	538651	FSM Clix M 8	101			
535541	STST 12 x 100	195	538652	FSM Clix M 10	101			
535542	STST 12 x 160	195	538653	FHS CLIX 8 x 30	103			
536978	FCA 21D - 300	121	538654	FHS CLIX 8 x 40	103			
536979	FCA 21D - 450	121	538655	FHS CLIX 8 x 60	103			
536980	FCA 21D - 600	121	538656	FHS CLIX 8 x 80	103			
537207	FCA 21 - 200	121	538657	FHS CLIX 8 x 100	103			
537208	FCA 21 - 300	121	538658	FHS CLIX 10 x 30	103			
537209	FCA 21 - 450	121	538659	FHS CLIX 10 x 40	103			
537210	BLR 100 M10	200	538660	FHS CLIX 10 x 60	103			
537211	SPS M 10	200	538661	FHS CLIX 10 x 100	103			
537212	FGRS 8 - 11	51	538663	HK 31 8,5	110			
537213	RD 3/4" / M 12 lang	203	538664	HK 31 10,5	110			
537214	RD 3/4" / M 16 lang	203	538665	SF Clix 31	105			
537215	RD 1/2" / M10 lang	203	538666	MW Clix 90°	107			

fischer Subsidiaries

Germany

fischer Deutschland Vertriebs GmbH

Klaus-Fischer-Str. 1
72178 Waldachtal
Tel.: +49 7443 12 6000
Fax.: +49 7443 12 4500
E-Mail: info@fischer.de
http://www.fischer.de

Argentina

fischer Argentina s.a.

Armenia 3044
1605 Munro Ra-PCIA Buenos Aires
Tel.: +54 1147 62 27 78
Fax.: +54 1147 56 13 11
E-Mail: asistencia tecnica@fischer.com.ar
http://www.fischer.com.ar

Austria

fischer Austria GmbH

Wiener Stra. 95
2514 Traiskirchen
Tel.: +43 2252 53730 0
Fax.: +43 2252 53730 70
E-Mail: office@fischer.at
http://www.fischer.at

Belgium

fischer Cobemabel snc

Schaliënhoedreef 20 D
2800 Mechelen
Tel.: +32 152 8 47 00
Fax.: +32 152 8 47 10
E-Mail: info@fischer.be
http://www.fischer.be

Brazil

fischer brasil Industria e Comercio Ltda.

Rua Dr. Rafael de Barros, 209 - 5º andar - Paraíso
04003-041 São Paulo - SP
Tel.: +55 11 3178 2545
Fax.: +55 11 3178-2544
E-Mail: fischer@fischerbrasil.com.br
http://www.fischerbrasil.com.br

China

fischer (Taicang) fixings Co. Ltd.

Jinzhou Road 18
215400 Taicang Jiangsu
Tel.: +86 512 53 58 89 38
Fax.: +86 512 53 58 89 48
E-Mail: ficn@fischer.com.cn
http://www.fischer.com.cn

Czech Republic

fischer international s.r.o.

Průmyslová 1833
25001 Brandýs nad Labem
Tel.: +42 03 26 90 46 01
Fax.: +42 03 26 90 46 00
E-Mail: info@fischer-cz.cz
http://www.fischer-cz.cz

Denmark

fischer a/s

Sandvadsvej 17 A
4600 Køge
Tel.: +45 46 32 02 20
Fax.: +45 46 32 50 52
E-Mail: fidk@fischerdanmark.dk
http://www.fischerdanmark.dk

Finland

fischer Finland Oy

Suomalaistentie 7 B
02270 Espoo
Tel.: +358 20 7414660
Fax.: +358 20 7414669
E-Mail: orders@fischerfinland.fi
http://www.fischerfinland.fi

France

fischer S. A. S.

12, rue Livio, P. O. Box 10182
67022 Strasbourg-Cedex 1
Tel.: +33 388 39 18 67
Fax.: +33 388 39 80 44
E-Mail: info@fischer.fr
http://www.fischer.fr

Greece

fischer Hellas Emporiki EPE

Nat. Road Athens-Lamia (17th) E; Roupef 6
Kifissia Athens
Tel.: +30 210 2838167
Fax.: +30 210 2838169
E-Mail: info@fischer.gr
http://www.fischer.gr

Hungary

fischer Hungária Bt.

Szerémi út 7/b
1117 Budapest
Tel.: +36 1 347 97 55
Fax.: +36 1 347 97 66
E-Mail: info@fischerhungary.hu
http://www.fischerhungary.hu

India

fischer BUILDING MATERIAL INDIA PVT LTD.

PRESTIGE GARNET UNIT NO- 401 , 4TH FLOOR 36,
ULSOOR ROAD
BANGALURU KARNATAKA-560042
E-Mail: info@fischer.in

Italy

fischer italia S.R.L

Corso Stati Uniti, 25, Casella Postale 391
35127 Padova Z.I. Sud
Tel.: +39 049 8 06 31 11
Fax.: +39 049 8 06 34 01
E-Mail: sercli@fischeritalia.it
http://www.fischeritalia.it

Japan

fischer Japan K.K.

Seishin Kudan Building 3rd Floor 3-4-15 Kudan Minami
Chiyoda-ku - 102-0074 Tokyo
Tel.: +81 3 3263 4491
Fax.: +81 3 6272 9935
E-Mail: info@fischerjapan.co.jp
http://www.fischerjapan.co.jp

Korea Republic of

fischer Korea Co., Ltd

#131, Kasan Digital-1Ro, Geumcheon-Gu
153-803 Seoul
Tel.: +82 1544 8955
Fax.: +82 1544 8903
E-Mail: info@fischerkorea.com
http://www.fischerkorea.com

Mexico

fischer Sistemas de Fijación, S.A. de C.V.

Blvd. Manuel Avila Camacho 3130-400B
54020 Col. Valle Dorado, Tlalneptlan, Estado de Mexico
Tel.: +52 55 55 72 08 83
Fax.: +52 55 55 72 15 90
E-Mail: info@fischermex.com.mx
http://www.fischermex.com.mx

Netherlands

fischer Benelux B.V.

Amsterdamsestraatweg 45 B/C
1411 AX Naarden
Tel.: +31 35 6 95 66 66
Fax.: +31 35 6 95 66 99
E-Mail: info@fischer.nl
http://www.fischer.nl

Norway

fischer Norge AS

Oluf Onsumsvei 9
0680 Oslo
Tel.: +47 23 24 27 10
Fax.: +47 23 24 27 13
E-Mail: ordre@fischernorge.no
http://www.fischernorge.no/

Philippines

fischer PH Asia, Inc.

No 100 Congressional Avenue, Project 8
1106 Quezon City
Tel.: +63 2426 / 0888 217
E-Mail: emmanuel.lopez@fischerph.com

Poland

fischerpolska Sp.z o.o

ul. Albatrosow 2
30-716 Kraków
Tel.: +48 12 2 90 08 80
Fax.: +48 12 2 90 08 88
E-Mail: info@fischerpolska.pl
http://www.fischerpolska.pl

Portugal

fischerwerke Portugal, Lda.

Av. Casal da Serra Nº 7, R/C
2625-085 Póvoa de Santa Iria
Tel.: +351 21 953 74 50
Fax.: +351 21 959 13 90
E-Mail: fischerportugal.info@fischer.es
http://www.fischer.pt

Russian Federation

000 fischer Befestigungssysteme Rus

I. Dokukina 16/1, Building 1
129226 Moscow
Tel.: +7 495 223 03 34
Fax.: +7 495 223 03 34
E-Mail: info@fischerfixing.ru
http://www.fischerfixing.ru

Singapore

fischer systems Asia Pte. Ltd.

150 Kampong Ampat #04-03 KA Centre
368324 Singapore
Tel.: +65 62 85 22 07
Fax.: +65 62 85 83 10
E-Mail: sales@fischer.sg
http://www.fischer.sg

Slovakia

fischer S.K. s.r.o.

Nová Rožňavská 134 A
831 04 Bratislava
Tel.: +421 2 4920 6046
Fax.: +421 2 4920 6044
E-Mail: info@fischerwerke.sk
http://www.fischer-sk.sk

Spain

fischer Ibérica S.A.U.

Klaus Fischer 1
43300 Mont-Roig del Camp Tarragona
Tel.: +34 977 83 87 11
Fax.: +34 977 83 87 70
E-Mail: servicio.cliente@fischer.es
http://www.fischer.es

Sweden

fischer Sverige AB

Tennngatan 4
602 23 Norrköping
Tel.: +46 11 31 44 52
Fax.: +46 11 33 1950
E-Mail: gg@fishersverige.se
http://www.fishersverige.se

Thailand

fischer Innovative Solutions Co.LTD.

38,40 Chaleom Prakiat Ratchakan-Thi 9 Road Soi 33
10250 Nongbon, Pravat, Bangkok
Tel.: +66 2 7473751
Fax.: +66 27473754
E-Mail: vinai@ssm-thailand.com
http://www.fischer.de

Turkey

fischer Metal Sanayi Ve Ticaret Ltd Sti

Cevizli Mahallesi, Mustafa Kemal Paşa Cad. Seyit Gazi Sok.
No 66, Hukukcular Towers A Blok - 34865 Kartal İstanbul
Tel.: +90 216 326 0066
Fax.: +90 216 326 0018
E-Mail: info@fischer.com.tr
http://www.fischer.com.tr

United Arab Emirates

fischer FZE

R/A 07, BA - 04, Jebel Ali Free Zone
Dubai
Tel.: +97 14 8 83 74 77
Fax.: +97 14 8 83 74 76
E-Mail: fixings@fischer.ae
http://www.fischer.ae

United Kingdom

fischer fixings UK Ltd.

Whitely Road
Oxon OX10 9AT Wallingford
Tel.: +44 1491 82 79 00
Fax.: +44 1491 82 79 53
E-Mail: info@fischer.co.uk
http://www.fischer.co.uk

United States

fischer America Inc.

1084 Doris Road
48326 Auburn Hills, Michigan
Tel.: +1 248 2 76 19 40
Fax.: +1 248 2 76 19 41
E-Mail: info@fisherus.com
http://www.fischerus.com

fischer distribution partners

Albania

fischer Austria GmbH
Wiener Straße 95
2514 Traiskirchen
Tel.: +43 2252 53730 0
Fax.: +43 2252 53730 70
E-Mail: office@fischer.at
www.fischer.at

Algeria

MEZACOM SA
34, avenue Ernest Pictet
1203 Geneva
Tel.: +41 22 344 20 44
Fax.: +41 22 344 20 45
E-Mail: lifmann@mezacom.ch

Siestal Sarl

Zone Industrielle
0600, Bejaia
Tel.: +34 21 26 58
Fax.: +34 20 15 69
E-Mail: marketing-mac@siestal-dz.com

Angola

C. Woermann Angola, Lda.
Km 4.5 Estrada de Cacucaco
Bairro Petrangol, LUANDA
Tel.: +244 227 270 185
E-Mail: c.poetsch@woermann-angola.com
www.c-woermann.de/pt/angola

BRICOMAT

Calçada do Município, Nº10 - R/C, 1ª e 2ª Pisos
Mutamba / LUANDA
Tel.: +244 928 157 572
E-Mail: geral@bricomat.com
www.bricomat.com / http://www.bricomat.com/en/ (english version)

Ovarmat Angola

Rua A, Quarteirão I, N.º 11, Bairro 1º de Maio
Viana / LUANDA
Tel.: +244 921 180 132
Fax.: +244 926 405 833
E-Mail: ovarmatangola@gmail.com

Armenia

Kasco Ltd.
Yervand Kochar str. 3-1 a
0070 Yerevan
Tel.: +374 10 57 55 00

Australia

Anchormark Pty.Ltd
61 Waterview Close
3175 Dandenong, Victoria
Tel.: +61 3 97992096
Fax.: +61 3 97992696
E-Mail: marcus@anchormark.com.au
www.anchormark.com.au

Azerbaijan

Fischer Metal Sanayi Ve Ticaret Ltd Sti
Cavizli Mahallesi, Mustafa Kemal Paşa Cad. Seyit
Gazi Sok. No 66, Hukukçular Towers A Blok
34865 Kartal İstanbul
Tel.: +90 216 326 0066 - Fax: +90 216 326 0018
E-Mail: info@fischer.com.tr
http://www.fischer.com.tr

Bahrain

M.H. Al Mahroos BSC (c)
Building No. 208, Shaikh Salman Highway, P.O.
Box 65, Salfhiya, Block 356 - Manama
Tel.: +973 17 40 80 90
Fax.: +973 17 40 43 23
E-Mail: almahroos@almahroos.com
www.almahroos.com

Bangladesh

Abedin Equipment Limited
B 52 Kemal Ataturk Avenue
1213 Banani, Dhaka
Tel.: +880 298 808 60
Fax.: +880 29862340
E-Mail: qk@accl.group-qk.com
www.abedinequipment.com

Barbados

Maxwell Trading Inc
Salters Warehouse Complex
Salters, St George
Tel.: +246 4293731
E-Mail: maxwelltrading@caribsurf.com

Belarus

MetalArtStroy
industrial area „zaozerye-1“
223141 d.Saoser 'je, Logovskij rn,
Minskaja obl.
Tel.: +375 172684557
E-Mail: metallartstroy@mail.ru

Bolivia

WAKO IMPORTAC.Y REPRESENTAC.
Av. Pedro Rivera #3550 Tercer Anillo Interno
531, SANTA CRUZ DE LA SIERRA
Tel.: +1578282012

NAUVOO IMPORTADORES

Calle Isaac Tamayo N° 840, Complejo Virgen del
Rosario, Bloque B, Local 04, zona Rosario
10392, La Paz
Tel.: +59122453782

Bosnia and Herzegovina

fischer Austria GmbH
Wiener Straße 95
2514 Traiskirchen
Tel.: +43 2252 53730 0
Fax.: +43 2252 53730 70
E-Mail: office@fischer.at
www.fischer.at

Botswana

Turbo Agencies (PTY) LTD
Plot 50647 Lejara Road
Broadhursts Industrial Gaborone
Tel.: +267 391 2288
E-Mail: admin@turboagencies.co.bw

Bulgaria

fischer Austria GmbH
Wiener Straße 95
2514 Traiskirchen
Tel.: +43 2252 53730 0
Fax.: +43 2252 53730 70
E-Mail: office@fischer.at
www.fischer.at

Cameroon

fischer S. A. S.
12, rue Livio, P. O. Box 10182
67022 Strasbour Cedex 1
Tel.: +33 388 39 18 67
Fax.: +33 388 39 80 44
E-Mail: info@fischer.fr
www.fischer.fr

Canada

Canadian Fasteners Hogedus Ltd.
1180 Ouest de Louvain West
Montréal, Québec H4N 1G5
Tel.: +1 514 381 3431
Fax.: +1 514 381 3688
E-Mail: bracine@anrgragscanadiens.com
www.anrgragscanadiens.com

Wm. P. Somerville Ltd.

3964 Kitchener Street
Burnaby BC V5C 3M2
Tel.: +1 604 298 36 22
Fax.: +1 604 298 59 26
E-Mail: wmp1996@telus.net

Chile

American Screw De Chile Ltda
Cno.A Melipilla 10338-C.1844
Zip code: 8320000 - Santiago de Chile
Tel.: +56 2440-7000

Colombia

Ingeniería Y Representaciones Sa
Calle 41 Norte Nro.1n-03
760003, Cali
Tel.: +572 3194020 4482521

Costa Rica

Industria Ceramica Costarricense S.A.
1.5 Km Oeste de Aviacion Civil, La Uruca
San Jose
Tel.: +506 25195433
E-Mail: Marietta.melendez@inccasatd.com
www.americanstandardca.com

Distribuidora Arsa S.A.

A. Guadalupe 400 MT ES-475 MT SUR
San José
Tel.: +506 22854224
E-Mail: lartavia@disarsa.com
www.disarsa.com

Tornillos Centroamericanos, S.A.

Av #10 entre calles #14 y #16
San José
Tel.: +506 25393939
E-Mail: pjerez@torcasa.cr
www.torcasa.cr

Croatia

fischer Austria GmbH
Wiener Straße 95
2514 Traiskirchen
Tel.: +385 16 235 935
Fax.: +385 16 235 882
E-Mail: office@fischer.at
www.fischer.at

Cyprus

Unic Chemicals Ltd.
10, P. Demetrikopoulou Street, P.O. Box 25606
1090 Nicosia
Tel.: +357 22663316
E-Mail: info@unicltd.com

Ecuador

Pino Aristata Sociedad Anonima
Luís Urdaneta Nr. 1909 Y Tulcan
AP09-04-500-GUAYAOUIL
Tel.: +593 42288000

Egypt

Modern Machines & Materials Co.
23, El Madina El Monawara Street
Cairo
Tel.: +20 3030251
E-Mail: enayatayab@gmail.com

Estonia

fischerpolska Sp.z o.o
ul. Albatrowsow 2
30-716 Kraków
Tel.: +370 601 61509
Fax.: +48 12 2 90 08 88
E-Mail: marek.smoleniec@fischerpolska.pl
www.fischerfixings.ee

Ethiopia

FOREVER Private Limited Company
P.O.Box 4806
Addis Abeba
Tel.: +251 11 1560600
Fax.: +251 11 1560189
E-Mail: foreverplc@ethionet.et

French Polynesia

fischer S. A. S.
12, rue Livio, P. O. Box 10182
67022 Strasbour Cedex 1
Tel.: +33 388 39 18 67
Fax.: +33 388 39 80 44
E-Mail: info@fischer.fr
www.fischer.fr

Gabon

fischer S. A. S.
12, rue Livio, P. O. Box 10182
67022 Strasbour Cedex 1
Tel.: +33 388 39 18 67
Fax.: +33 388 39 80 44
E-Mail: info@fischer.fr
www.fischer.fr

Georgia

Decorum Ltd.
Tornike Eristavi Str. 2
0192 Tbilisi
Tel.: +995 55511972
Fax.: +995 32 266 7331
E-Mail: irakli@decorum.ge
www.bellemaison.ge

Ghana

C. Woermann (Ghana) Limited
C362/1 Nsawam Road / Avenor Junction
P. O. Box GP 1779, ACCRA
Tel.: +233(0)30-222 51 41
Fax.: +233(0)30-223 00 16
E-Mail: info@woermann-ghana.com
www.c-woermann.com/en/ghana

Guadeloupe

fischer S. A. S.
12, rue Livio, P. O. Box 10182
67022 Strasbour Cedex 1
Tel.: +33 388 39 18 67
Fax.: +33 388 39 80 44
E-Mail: info@fischer.fr
www.fischer.fr

Guatemala

Compañía Comercial e Industrial Electro Diesel de Guatemala, S. A
8A calle 6-62-Zona 4
01004, Guatemala
Tel.: +502 24940000
E-Mail: christian.bauer@edisa.com.gt
www.edisa.com.gt

Industria Centroamericana de Sanitarios, S.A.

0 Calle 9-70 Zona 10
01066, San Miguel Petapa
Tel.: +506 25165452
www.americanstandardca.com

Guyana

fischer S. A. S.
12, rue Livio, P. O. Box 10182
67022 Strasbour Cedex 1
Tel.: +33 388 39 18 67
Fax.: +33 388 39 80 44
E-Mail: info@fischer.fr
www.fischer.fr

Honduras

Importadora Ferrerera S.A
17 Calle Circunvalacion 5 Y6
San Pedro Sula
Tel.: +504 25541848
www.imferra.com

Larach & Cia, S. de R.L. de C.V

1347 Calle de la Salud, Colonia Miramontes
Tegucigalpa M.D.C
Tel.: +504 22901100
E-Mail: josevalladares@larachycia.com
www.larachycia.com

Industrial Ferrtera, S.A. de C.V.

Calle Principal 401, San José del Pedregal
Comayaguella M.D.C.
Tel.: +504 22448000
E-Mail: elopez@indufesa.com
www.indufesa.com

Hong Kong

Infix (HK) LTD
12 Ka Yip Street, Unit 15, 12/F, Paramount
Building
Chai Wan
Tel.: +852 2898 26 68
Fax.: +852 2898 23 38
E-Mail: barry@infix.com.hk

Iceland

BYKO hf
Skemmuvegji 2a
200 Kopavogur
Tel.: +354 515 4085
Fax.: +354 515 4099
E-Mail: hugrun@byko.is
www.byko.is

India

FISHER BUILDING MATERIAL INDIA PVT LTD.
PRESTIGE GARNET - UNIT NO- 401 , 4TH FLOOR -
36, ULSDOR ROAD
BANGALURU - KARNATAKA-560042
E-Mail: info@fischer.in
www.fischer.in

Indonesia

PT BERSAMA Bangun Persada
Perkantoran Mega Sunter Blok D10-11
Jakarta Utara 14350
Tel.: +62 21 65837575
Fax.: +62 21 65835363
E-Mail: hendrik@msafetygroup.com
www.msafetygroup.com

Iran

Abzarsara Co.
148, Sanai St.
15866 Teheran
Tel.: +98 21 888 13 120
E-Mail: alireza.ramzgooyan@abzarsara.com
www.abzarsara.com

Ireland

Masonry Fixings Services Ltd.
Unit 83, Cherry Orchard Industrial Estate
Dublin 10
Tel.: +353 1 642 6700
Fax.: +353 1 26 3493
E-Mail: bryan@masonryfixings.ie
www.masonryfixings.ie

Israel

Ledico Ltd.
Lazarov St. 31
Rishon Le Ziyon
Tel.: +972 396 300 00
Fax.: +972 3963 00 55
E-Mail: doronb@ledico.com
www.ledico.com

Ivory Coast

fischer S. A. S.
12, rue Livio, P. O. Box 10182
67022 Strasbour Cedex 1
Tel.: +33 388 39 18 67
Fax.: +33 388 39 80 44
E-Mail: info@fischer.fr
www.fischer.fr

Jordan

IZZAT Musa Marji and Sons Co.Ltd
No. 10, Amer Bin Malek St,Um Sumaq
P.O. Box 1945, Amman 11821
Tel.: +962 655 202 84
E-Mail: mohd.taha@marji.jo
www.marji.jo

Kazakhstan

fischerpolska Sp.z o.o
ul. Albatrowsow 2
30-716 Kraków
Tel.: +48 605 106 657
Fax.: +48 12 2 90 08 88
E-Mail: marek.smoleniec@fischerpolska.pl
www.fischerpolska.pl

Kenya

Alibhai Shariff & Sons Ltd.
P.O. Box 40382-00100, Mombasa Road
Nairobi, Kenya
Tel.: +254 206905000
Fax.: +254 206905111
E-Mail: saifuddin@alibhaishariff.co.ke
www.alibhaishariff.com

THORN ELECTRICALS LTD

10 LOKITANG ROAD, OFF LIKONI ROAD,
INDUSTRIAL AREA
P.O. BOX 47410 - 00100 GPO, NAIROBI, KENYA
Tel.: +254 734 523442 S Fax.: +254733734444
E-Mail: chirag.amin@thornpower.co.ke
www.thornpower.co.ke

Kosovo

fischer Austria GmbH
Wiener Straße 95
NAIROBI, KENYA
Tel.: +43 2252 53730 0
Fax: +43 2252 53730 70
E-Mail: office@fischer.at
www.fischer.at

Kuwait

M/S SAFINA AL NAJJAT CO.
Shuwaikh - Khalifa Jassim Street, P.O.Box 20329,
Safat 13064
Kuwait City
Tel.: +965 2481 8786
Fax: +965 2481 8385
E-Mail: bhagat@safinanajjat.com

Latvia

fischerpolska Sp.z o.o
ul. Albatrosow 2
30-716 Kraków
Tel.: +370 601 61509
Fax: +48 12 2 90 08 88
E-Mail: marek.smolniewicz@fischerpolska.pl
www.fischerfixings.lv

Liberia

Beever Company Inc.
U.N. Drive, Vai Town
Monrovia - Liberia
Tel.: +231 - 8866511112
E-Mail: info@beever.com
http://www.beever.com/

Lithuania

fischerpolska Sp.z o.o
ul. Albatrosow 2
30-716 Kraków
Tel.: +370 601 61509
Fax: +48 12 2 90 08 88
E-Mail: marek.smolniewicz@fischerpolska.pl
www.fischerfixings.lt

Luxembourg

Hilger Interfer S.A.
36-37, z.a.e. Triangle Vert
5691 Ellange
Tel.: +352 48 48 15 1
Fax: +352 48 48 15 350
E-Mail: info@hilger.lu
www.hilger.lu

Macedonia

fischer Austria GmbH
Wiener Straße 95
2514 Traiskirchen
Tel.: +43 2252 53730 0
Fax: +43 2252 53730 70
E-Mail: office@fischer.at
www.fischer.at

Madagascar

fischer S. A. S.
12, rue Livio, P. O. Box 10182
67022 Strasbour-Cedex 1
Tel.: +33 388 39 18 67
Fax: +33 388 39 80 44
E-Mail: info@fischer.fr
www.fischer.fr

Malaysia

Defix Concrete Products Sdn Bhd
No. 1, Lorong Jintan 2, Taman Supreme Off
Jalan Cheras
56100 Kuala Lumpur
Tel.: +603 9134 8600
E-Mail: defixcp@gmail.com

Maldives

Sonee Hardware
Sonee Building, 181 Boduthakurafaanu Magu
Male, 20181
Tel.: +960 330 635 8
Fax: +960 334 575 3
E-Mail: ahmed.alam@sonee.com.mv
www.sonee.com.mv

Malta

Tessera Ltd.
Dockyard Street, PLA 2115
Paola
Tel.: +356 99426724
Fax: +356 27490100

Martinique

fischer S. A. S.
12, rue Livio, P. O. Box 10182
67022 Strasbour-Cedex 1
Tel.: +33 388 39 18 67
Fax: +33 388 39 80 44
E-Mail: info@fischer.fr
www.fischer.fr

Mauritius

DEMA-SUPPLIES LTD
2A Deschartes Street
56290 Port Louis
Tel.: +230 2126405
Fax: +230 2107457
E-Mail: dema@intnet.mu

Mayotte

fischer S. A. S.
12, rue Livio, P. O. Box 10182
67022 Strasbour-Cedex 1
Tel.: +33 388 39 18 67
Fax: +33 388 39 80 44
E-Mail: info@fischer.fr
www.fischer.fr

Moldova

Altosan SRL
Susev str. 78
2023 Chisinau
Tel.: +373 22222797
E-Mail: victor.balca@altosan.md
www.altosan.md

Monaco

fischer S. A. S.
12, rue Livio, P. O. Box 10182
67022 Strasbour-Cedex 1
Tel.: +33 388 39 18 67
Fax: +33 388 39 80 44
E-Mail: info@fischer.fr
www.fischer.fr

Montenegro

fischer Austria GmbH
Wiener Straße 95
2514 Traiskirchen
Tel.: +43 2252 53730 0
Fax: +43 2252 53730 70
E-Mail: office@fischer.at
www.fischer.at

Morocco

Outipro
163-165 Rue Mohamed Smiha
Casablanca
Tel.: +212 522 47721
Fax: +212 522 40 8234
E-Mail: ajana.zineb@outipro.ma
www.fischer.at

Mozambique

Nova Vida Lda
Rua Paulino Santos Gil 94
Maputo
Tel.: +258 21 327370
Fax: +258 21 327371
E-Mail: info@novavida.co.mz
www.novavida.co.mz

Spartacus LDA

Estrada da Mozal
Parcela 510 Matola Rio
Tel.: +258 21 730 447
E-Mail: werner@spartacus.co.mz

Myanmar, Yangon

TIGER SUPPLY CO., LTD
19/21 Station Road/ Bank Htw
YANKIN TOWNSHIP, YANGON
Tel.: 01-400411
Fax: 01-430559
E-Mail: tigeryangon@gmail.com
www.tigersupplymyanmar.com

Namibia

Werner Behnsen Enterprises
6 Kallie Roodr Street,
Northern IND. Area Windhoek
Tel.: +264 61234234
Fax: +264 61 225 353
E-Mail: admin@kiritechnamibia.com

Netherlands Antilles

Caribbean Fasteners Group
Emancipatieboulevard 29, PO BOX6052
Willemstad
Tel.: +599 97376288
E-Mail: purchase@cfh-group.com

New Caledonia

fischer S. A. S.
12, rue Livio, P. O. Box 10182
67022 Strasbour-Cedex 1
Tel.: +33 388 39 18 67
Fax: +33 388 39 80 44
E-Mail: info@fischer.fr
www.fischer.fr

Nigeria - Exporteur Hamburg

C. Woermann (Nigeria) Ltd.
6, Badojo Kalesanwo Street, Matori Industrial
Estate
Lagos
Tel.: +234 17736498
E-Mail: info@woermann-nigeria.com
www.c-woermann.com/en/nigeria

Oman

Technical Supplies International Co LLC
Al Athaibah, Sultanate of Oman, Post Box: 1827,
Postal Code: 130
Tel.: +968 2450 39 15
Fax: +968 2450 39 20
E-Mail: venugopal@tecsintl.com
http://www.tecsintl.com

Pakistan

H.S.AHMEDALLY
Plot- 14/A/1, Block-6, PECHS, Shara-e-Faisal,
Adjacent KFC Nursery
Karachi
Tel.: +92 21 34548345 47
Fax: +92 21 34548348
E-Mail: sghazanfar@hsahmedally.com

Paraguay

PETERSEN INDUSTRIA & HOGAR S.A
Santo Tomas #1653 C/ Avda. Artigas
1645, Asuncion
Tel.: +59521206131

Qatar

Team Pro Qatar
Doha/Muayezr-Saylia Road 250
Doha
Tel.: +974 4 451 5976
Fax: +974 4 451 5974
E-Mail: customerservice-qatar@team-pro.info

Reunion

fischer S. A. S.
12, rue Livio, P. O. Box 10182
67022 Strasbour-Cedex 1
Tel.: +33 388 39 18 67
Fax: +33 388 39 80 44
E-Mail: info@fischer.fr
www.fischer.fr

Romania

SC Profix SRL
Calea Baciului Nr. 179
400230 Cluj-Napoca
Tel.: +40 264 455166
Fax: +40 264 403060
E-Mail: office@profix.com.ro
www.profix.com.ro

Russia/ Kaliningrad

Inform Ltd.
Suvorova 125-A
236028 Kaliningrad
Tel.: +7 65 11 00
Fax: +7 65 11 00
E-Mail: inform@inform.koenig.ru
www.inform-expert.ru

Rwanda

Maltext Ltd.
Plot 808, KG 15th av.
Kacyiru- Kigali
Tel.: +250 788411422
E-Mail: info@maltext.com

Saudi Arabia

Juffali Technical Equipment Company (JTECO)
Kilo 6, Madinah Road, P.O. Box 1049
Jeddah 21431
Tel.: +966 2 6672222 · Fax: +966 2 6676308
E-Mail: roland@ejb.com.sa
www.ejb.com

Senegal

Groel Senegal
AMITIE III VILLA No 4436
22788 Dakar-Ponty
Tel.: (221)33 825 39 48
Fax: (221)33 825 39 47
E-Mail: groel@groel.sn
www.groel.sn

fischer S. A. S.

12, rue Livio, P. O. Box 10182
67022 Strasbour-Cedex 1
Tel.: +33 388 39 18 67
Fax: +33 388 39 80 44
E-Mail: info@fischer.fr
www.fischer.fr

Serbia

fischer Austria GmbH
Wiener Straße 95
2514 Traiskirchen
Tel.: +43 2252 53730 0
Fax: +43 2252 53730 70
E-Mail: office@fischer.at
www.fischer.at

Sierra Leone

Eugene Ilono Enterprises
56 Lower Bombay Street
FREETOWN
Tel.: +232 33445630
E-Mail: eugeneilono@gmail.com

Slovenia

fischer Austria GmbH
Wiener Straße 95
2514 Traiskirchen
Tel.: +43 2252 53730 0
Fax: +43 2252 53730 70
E-Mail: office@fischer.at
www.fischer.at

South Africa

Upat S.A. (Pty) Ltd.
1st Floor Larkroom House, Cnr. 3rd & Miller Streets
New Doornfontein 2094, Johannesburg
Tel.: +27 116246715
Fax: +27 116246760
E-Mail: ideas@upat.co.za
www.upat.co.za

Sri Lanka

Diesel & Motor Engineering PLC.
65, Jetawana Road, P.O. Box 339
Colombo 14
Tel.: +94 112 449 797
Fax: +94 244 908 0
E-Mail: kumar.rodrigo@dimolanka.com
www.dimolanka.com

St. Pierre and Miquelon

fischer S. A. S.
12, rue Livio, P. O. Box 10182
67022 Strasbour-Cedex 1
Tel.: +33 388 39 18 67
Fax: +33 388 39 80 44
E-Mail: info@fischer.fr
www.fischer.fr

Swaziland

Tech-Tool 2000 (Pty) Ltd
Plot 628, 5th Avenue
Matsapha
Tel.: +268 25 186621
Fax: +268 25 186411
E-Mail: sales@techtool.co.sz

Switzerland

SFS unimarket AG Befestigungstechnik
Nefenstrasse 30
CH-9435 Heerbrugg
Tel.: +41 71 727 6055
Fax: +41 71 727 6171
E-Mail: ob@sfsunimarket.biz
www.sfsunimarket.biz

SFS unimarket AG Befestigungstechnik

Blegi 14
CH-6343 Rotkreuz
Tel.: +41 41 798 2538
Fax: +41 41 798 2575
E-Mail: scma@sfsunimarket.biz
www.sfsunimarket.biz

SFS/Rheineck Distributionszentrum

Route de Grandcour 66
Payerne
Tel.: +41 71 8862 865
Fax: +41 71 8862 860
E-Mail: asg@sfsunimarket.biz
www.sfsunimarket.biz

Syria

Sawsan Rita Dallal
P.O. Box 8303 Barron Street
Aleppo - Machroutieh
E-Mail: rita.dallal@hotmail.com

Taiwan

Cheng Yi Fixing Co. Ltd.
N04LN152,Zhongping RD,
100 Taipei City
Tel.: +886 911158918
E-Mail: lgco.paul@gmail.com

Fu Hau

Da-An Rd. No. 7,
Taipei City, R.O.C.
Tel.: +886 2 2773 5110
Fax: +886 2 25418008
E-Mail: swapnal@ms61.hinet.net

Perfect Link Co. Ltd.

2 Fl.No 261, Siyuan Road
231 Taipei, Sindian City
Tel.: +886 2 22 19 4698
Fax: +886 2 22 19 9939
E-Mail: harvey@perfectlink.com.tw

Seven Technology Co. Ltd.

5 F, No. 25, Lane 38, Sec. 2, Jhongsiao Rd,
Sanchoing City County 241
Taipei
Tel.: +886 2 29992048
Fax: +886 2 29996545
E-Mail: kentio@livemail.tw

Fibretec Systems Co. Ltd.

3F, No 2, Alley 6, Lare 36
Tapei City
Tel.: +886227605563
E-Mail: fibretec@cahoo.com

Tanzania

Nabaki Afrika
P.O. Box 11747
Dar es Salaam
Tel.: +255 222775138
E-Mail: jeff@nabaki.com

Togo

fischer S. A. S.
12, rue Livio, P. O. Box 10182
67022 Strasbour-Cedex 1
Tel.: +33 388 39 18 67
Fax: +33 388 39 80 44
E-Mail: info@fischer.fr
www.fischer.fr

Tunisia

TEG Tunisienne Équpement General
43, Av. Hédi Chaker
1002 Tunis
E-Mail: fathia@regnegoce.com

fischer distribution partners

Turkey

Fischer Metal Sanayi Ve Ticaret Ltd Sti
Cevizli Mahallesi, Mustafa Kemal Paşa Cad. Seyit
Gazi Sok. No 66, Hukukcular Towers A Blok
34865 Kartal İstanbul
Tel.: +90 216 326 0066 - Fax: +90 216 326 0018
E-Mail: info@fischer.com.tr
http://www.fischer.com.tr

Turkmenistan

Fischer Metal Sanayi Ve Ticaret Ltd Sti
Cevizli Mahallesi, Mustafa Kemal Paşa Cad. Seyit
Gazi Sok. No 66, Hukukcular Towers A Blok
34865 Kartal İstanbul
Tel.: +90 216 326 0066 - Fax: +90 216 326 0018
E-Mail: info@fischer.com.tr
http://www.fischer.com.tr

Uganda

Maltexx Ltd.
Plot 84-88, 7th street, Industrial area, P.O.
Box 35789
Kampala
Tel.: +256 775 965 389
E-Mail: info@maltexx.com

Ukraine

fischerpolska Sp.z o.o
ul. Albatrosow 2
30-716 Kraków
Tel.: +48 605 106 657
Fax: +48 12 2 90 08 88
E-Mail: marek.smolencic@fischerpolska.pl
www.fischerpolska.pl

United States of America

HQ- ARMY & AIR FORCE EXCHANGE
P. O. BOX 660261
Dallas, Tx 75266-0261
Tel.: +1 217 726 5938
Fax: +1 217 726 5953
E-Mail: marc@weedouthate.org

Uruguay

Pampin Y Cia
Valparaiso 1199
11800, Montevideo
Tel.: +5982-924-0608

Record Tools S.A.

Paysandu 951
11100, Montevideo
Tel.: +5982-902-7492

Juan Goldfarb S.A.

Rio Negro 1617
11100, Montevideo

Landfor S.A.

Ituzaingo Sur Rincon 531 Es302
20000, Zona Franca Florida
Tel.: +5982 9161164

Uzbekistan

Fischer Metal Sanayi Ve Ticaret Ltd Sti
Cevizli Mahallesi, Mustafa Kemal Paşa Cad. Seyit
Gazi Sok. No 66, Hukukcular Towers A Blok
34865 Kartal İstanbul
Tel.: +90 216 326 0066 - Fax: +90 216 326 0018
E-Mail: info@fischer.com.tr
http://www.fischer.com.tr

Venezuela

IMPEX DE VENEZUELA C.A.
Av. Este 1, Galpon 02 Parcela N° 61, Zona
Industrial LA MORITA I
2115 TURMERO-ARAGUA
Tel.: +584402432695019

Vietnam, Hanoi

Viet Technology & Development Jsc
Suite 234, 33a Pham Ngu Lao
Hanoi
Tel.: +84 4 3933 4548
Fax: +84 4 3933 4549
E-Mail: linh.vu@viet-tech.vn
www.viet-tech.vn

Vietnam, Ho Chi Minh

Huu Hong Machinery JSC
157-159 Xuan Hong Street, Ward 12
Ho Chi Minh City
Tel.: +84 8 8117454
Fax: +84 8 8116338
E-Mail: fischer@huuhong.com.vn
www.huuhong.com.vn

Zambia

Turbo Agencies Zambia Limited
Plot No 4065
Mukilakwenda Road Kitwe
Tel.: +260 212 219082
E-Mail: nick@turboagencies.co.zm

Zimbabwe

Mining & Industrial Suppliers
2 Hood Road
Southern Harare
Tel.: +263 4621 796
E-Mail: john@mis.co.zw



The information in this catalogue is intended for general guidance only and is given without engagement. Additional information and advice on specific applications is available from our Technical Support Team. For this however, we require a precise description of your particular application. All the data in this catalogue concerning work with our fixing elements must be adapted to suit local conditions and the type of materials in use.

If no detailed performance specifications are given for certain articles and types, please contact our Technical Service Department for advice.

fischerwerke GmbH & Co. KG
72178 Waldachtal
Germany

We cannot be responsible for any errors, and we reserve the right to make technical and range modifications without notice. No liability is accepted for printing errors and omissions.

03/2017



Contact

fischerwerke GmbH & Co. KG
Klaus-Fischer-Straße 1
72178 Waldachtal
Germany

Phone: (0049) 7443 12-0
Fax: (0049) 7443 12-4222
E-mail: info@fischer.de
www.fischer.de

Your dealer



103746 · 03/2017 · V-MKS/CI · Printed in Germany

